



specializing in “AIR CONDITIONING, PARTS AND SYSTEMS” for your classic

# “PERFECT FIT SERIES”

## IN-DASH

HEAT/ COOL/ DEFROST  
1967-68 MUSTANG

### CONTROL & OPERATING INSTRUCTIONS

The controls on your new “Perfect Fit” system. Offers complete comfort capabilities in virtually every driving condition. This includes Temperature control in all of the modes. This system also provides the ability to blend the air between Face, Heat, and Defrost modes simultaneously.

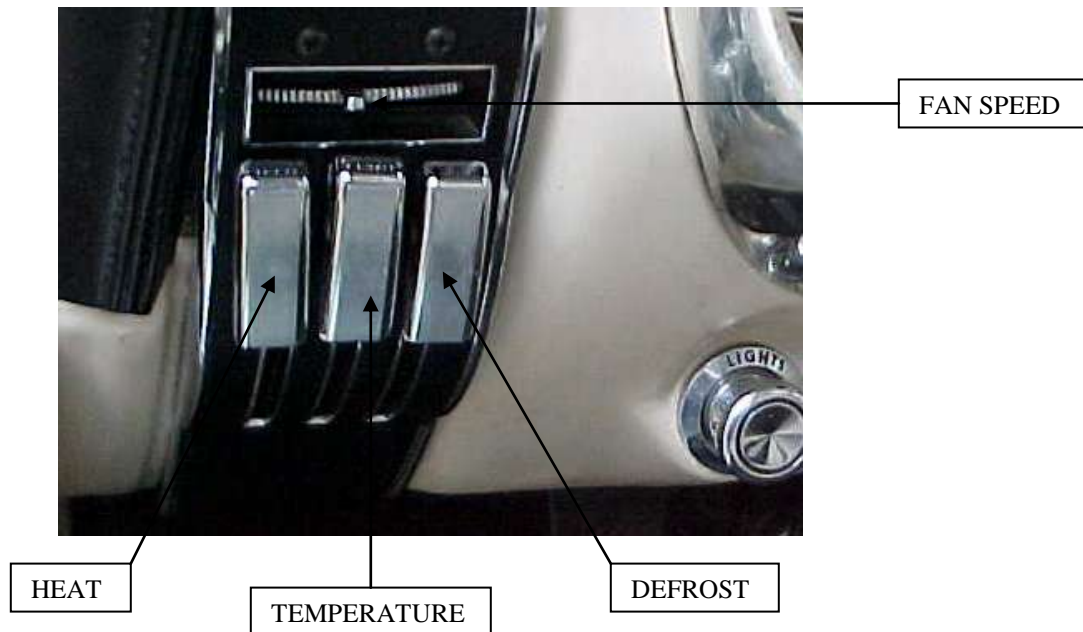

THE PICTURE YOU SEE ABOVE SHOWS THE CONTROLS IN THE FACE MODE. THIS MEANS THAT ALL OF THE AIR WILL BE DISTRIBUTED THROUGH THE DASH LOUVERS. THIS ALSO HAS THE TEMPERATURE LEVER IN THE COLD POSITION. WITH THE CONTROLS IN THIS POSITION YOU WILL GET THE AIR THROUGH THE DASH LOUVERS AT ROOM TEMPERATURE.

**CAUTION:** ALL OF THE OUTSIDE VENTS MUST BE CLOSED WHEN THE SYSTEM IS IN THE A/C MODE. THIS WILL ALLOW THE A/C SYSTEM TO FUNCTION AT ITS MAXIMUM PERFORMANCE LEVEL.

THE FOLLOWING SUMMARY WILL DESCRIBE EACH OF THE CONTROL LEVERS FUNCTION.

**FAN SPEED SWITCH:** There are 3 speeds plus Off. When the switch is in the off position it will disconnect the 12V power to the Blower Motor and the A/C Clutch. This will shut down the entire system. When the switch is moved to any of the blower speeds 1,2 or 3 there is 12V supplied to the Micro-Switch which is mounted on the defrost air housing.

**HEAT MODE:** When the heat lever is pushed down, it will allow the air to go between the floor ducts and the face louvers. Only when the lever is in the lowest position will all of the air stop coming out of the face louvers and blow on the floor.

**TEMPERATURE CONTROL:** The temperature lever as shown is in the COLDEST temperature position. As the lever is pushed down the temperature of the discharged air will rise to the HOTTEST point which is the lowest position of the lever. Note: The temperature lever will function in any of the modes.

**DEFROST MODE:** This system allows for Dehumidification of the air in the Defrost mode. The Heat lever must be in the down position. The lever marked DEF. must be at the bottom position in order to get the maximum air flow to the windshield and to trip the Micro-Switch. This will activate the Compressor Clutch.

**AIR CONDITIONING MODE:** The picture shows the controls in the Face Mode (air-flow out the dash louvers).

When Air Conditioning is required the compressor clutch must be activated. This is accomplished by pushing the Def. lever all the way to the bottom. When the compressor is activated the Temperature Lever will control the air from maximum cold through maximum heat.



specializing in “AIR CONDITIONING, PARTS AND SYSTEMS” for your classic

## ***INSTALLATION INSTRUCTIONS 1967-68 MUSTANG***

Congratulations! ! You have just purchased the highest quality, best performing A/C system ever designed for you Classic Car. To obtain the high level of performance and dependability our systems are known for, pay close attention to the following instructions.

Before beginning the installation check the box for the correct components.

Evaporator  
Face Duct Assembly  
Defrost / Heat Duct Assembly  
Inlet Air Block Off Assembly  
Firewall Block Off Assembly  
Flex Hose 2”dia. (2) 2’, (1) 3’  
Flex Hose 2 ½”dia. (2) 2’, (1) 3’  
Sack Kit Hardware  
Sack Kit Control

## ***IMPORTANT INFORMATION***

1. Before starting, read the instructions carefully and follow proper sequence.
2. Check condition of engine mounts. Excessive engine movement can damage hoses to A/C, heater, radiator, transcooler, and power steering systems.
3. Before starting, check vehicle interior electrical functions. i.e. interior lights, radio, horn, etc. When ready to start installation, disconnect battery.
4. Fittings. Use one or two drops of lubricant on O’rings, threads and rear of bump for O’ring where female nut rides. Do not use thread tape or sealants.
5. Always use two wrenches to tighten fittings. Try holding in one hand while squeezing together while other hand holds fitting in position.
6. Shaft seals in a small percentage of compressors will require as much as 3-4 hours run time to become leak free.
7. Compressors supplied in our complete systems are filled with proper amount of oil.
8. Compressor requires technician to hand turn 15-20 revolutions before and after charging with liquid from a charging station before running system. Compressors with damaged reed valves cannot be warranted.
9. Should you have any technical questions, or are suspect of missing, or defective parts, call us immediately. Our knowledgeable staff will be glad to assist you.

***YOU CAN NOW BEGIN THE  
INSTALLATION***

Remove Glove box, Ashtray, and Radio (with bezel), set aside for reinstall.

Note: If vehicle is equipped with a console remove and retain.



The removal of the Original Heater Assembly can be accomplished by disconnecting three control cables. One attached to Heat/Defrost door.



One attached to Temperature door as shown. And one attached to Vent / Heat door.

Disconnect electrical harness.



Also remove attachment screw located in front of air inlet.

Locate blower motor on the firewall (Passenger Side) in the engine compartment. Remove 4 nuts around blower. Also disconnect electrical connector from blower motor.

Cut wires at grommet in firewall.

**DRAIN COOLANT FROM RADIATOR.**  
Cut Heater hoses approximately 1" from firewall.



Carefully remove staples in the defrost connectors at base of the windshield.

Remove complete Heater Assembly and defrost flex ducting. Discard.



Remove Control Head Assembly. Remove the Control Cables and the Original Blower Switch and discard. Set the control head aside for modification and reinstall.

**NOTE: RETAIN ALL OF THE ORIGINAL HARDEWARE.**



Remove the Center Trim Bezel as shown.  
Discard.



VIEW SHOWING BACK SIDE OF  
TRIM BEZEL.  
UTILIZING A DEEP 5/8 SOCKET  
REMOVE AND RETAIN NUT.

Opening in the instrument panel  
that was behind Center Trim  
Bezel previously discarded will  
require modification.



In the Hardware Sack Kit you will  
find a Center Louver Assembly.  
Carefully enlarge the hole so that  
you can just fit louver assembly  
through opening. Do not install at  
this time.



Locate trim panel to the right of the glove box opening. Locate and cut a 2" dia. hole, 4" from the upper edge of trim panel. Drill hole in the center from left to right.

**CAUTION:** *It is recommended that you cut this hole with a round hole saw. It is important that this hole be 2" ~ 2 1/32" dia.*

Locate 2" dia. snap in hose adaptor from the Hardware Sack Kit. Install this through 2" dia. hole previously cut.



Locate original wiring harness that supplied power to the original heater motor. These wires were previously cut on engine side of the firewall. Behind glove box opening pull these wires out of their grommet. Measure 4" from harness cut both wires. On the black wire attach a 1/4" insulated male spade connector.

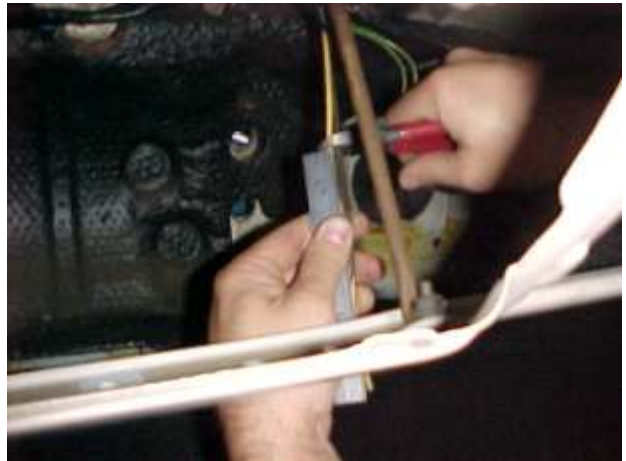

Locate bottom left mounting hole in the firewall that attached the original heater motor. From inside of the vehicle drill a 5/8 dia. hole for the drain tube. This is located as shown.

**NOTE:** TEMPLATE LOCATED ON PAGE 23 OF INSTRUCTIONS.

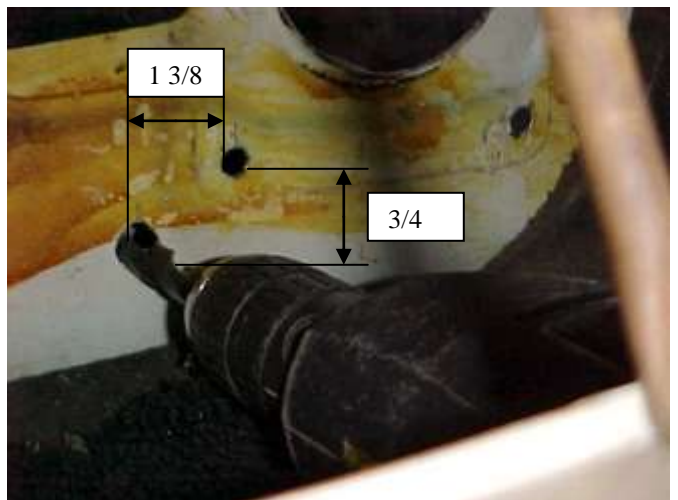

***Caution: on the engine side of the firewall there is a brake line. Do not drill through. It may be necessary to carefully relocate this line.***



***All modifications to the vehicle are complete. You can now begin installing your Classic Air “Perfect Fit Series” System.***

Locate Air Inlet Block off Assembly.  
Install over hole in inlet cowl as shown.  
Attach with (2) #10 x ¾ Tek screws.



Locate two mounting locations as shown  
and attach the ¼-20 J-clips supplied.



Install the Evaporator in vehicle.

One 1/4-20 x 5/8 screw and 1/4" SAE washer, attaches through firewall as shown. This location is the bottom right hole that attached the original heater assembly.



The second 1/4-20 x 5/8 screw attaches blower motor mounting bracket in the same location as original heater mounting in front of the Air Inlet. The blower support bracket will have an additional hole behind the 1/4-20 screw. Install a #10x3/4 Tek screw supplied, through this hole and into the cowl.



Locate in Hardware Sack Kit the UPPER MOUNTING BRACKET and attach to evaporator using (2) #10 x 5/8 pan head philips screw. The other end will line up to the mounting location where you installed the J-clip. Attach with the remaining 1/4-20 x 5/8 screw.

Attach Support brace on left side of Evaporator using a #6 clamp from the Hardware sack kit as shown. Attach with #10 x 5/8 screw.



Locate in the Hardware Sack Kit the Firewall Block Off Assembly. Install over the hose connections in the engine compartment. Attach with (2) #10 x 3/4 Tek screws. Seal around tubes with refrigerant tape.

Locate in the engine compartment the heater hose hookups and refrigerant connections. It is recommended that you replace the heater hose from engine to the tube hookups.

The supply line from engine will be attached to lower heater connection as shown. Return line will be attached to the upper heater connection. Cut 6" of the return line to be used between water valve and the hookup tubes. Attach water valve with #10 worm gear clamps supplied in kit. See Technical data sheet on page 23.



Locate in the Hardware Sack Kit a 6" piece of 1/2" dia. clear Drain tube. Insert this through 5/8 dia. hole previously drilled and attach over drain nipple as shown. Seal around tube with refrigerant tape.

Locate the 2" dia. Flex duct.

Find a 2' piece and attach to the right defrost outlet on the duct.

Find a 2' piece and attach to the left defrost outlet on the duct.

Locate Defrost Duct Assembly and install on Evaporator as shown. Use (2) #10 x 5/8 pan head screws. NOTE: Make sure that the S-Clips are properly pushed over outlet flange.



Attach the Defrost hoses to the original ducts using the 2" x 2 1/2" Defrost Adaptors.

Locate Control Head that was previously removed.

Locate Control Switch Mounting Bracket, and Blower Switch in the Control Sack Kit. Attach bracket to the control head with original screw. Attach switch to the bracket using (2) #8 x 3/8 pan head screws. Attach Switch Knob by pressing over lever.

Attach (3) control cables to the control head utilizing the Cable Mounting Bracket and original screws as shown. The longest cable goes in the middle, shortest cable to the right and the last one goes on the left. (See picture). The cable housing should be above the mounting point 3/8".

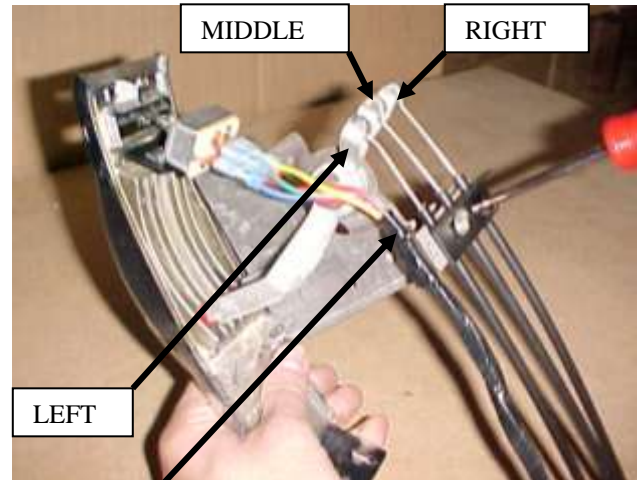

Also attach the Wire Harness Assembly to the Blower Switch.

Reference: The Electrical Diagram on page 21 for correct connector location.

Loosely install Control Assembly through opening in the Instrument Panel and route cables and the electrical harness. Hook up the electrical connections per Electrical Diagram on page 21.



**Note: Refer to line drawing for correct routing.**



Shortest cable attached to the control head should be routed and connected to the Defrost Duct Assembly.

NOTE: Insert cable wire into third hole from the end of the crank arm. Use #10 x 5/8 pan head screw.

Route cable attached to the Heat lever and attach to the Face/ Heat door, located on Evaporator.

NOTE: Insert cable wire into fifth hole from the end of crank arm.

Attach using (1) #10 x 5/8" pan head screw.



INSTALL (2) 1" Dia. CAP PLUGS OVER HOLES. SLOT TOP ONE FOR CABLE.

Route longest cable along the firewall and out through the upper hole that was used by the original heater hose. Attach cable in the engine compartment to the water valve.

NOTE: When Temperature lever is at the top position water valve should be closed.



Locate a 3' piece of 2" dia. Flex hose. Route through instrument panel, from control panel to center of the Instrument Panel.

Reinstall control panel along with Drivers Side Louver. Attach using the original hardware.

Attach duct hose to Louver using (1) #10 x 5/8 pan head screw.



DRIVERS SIDE LOUVER

3' FLEX HOSE

**CAUTION:** Control cables are equipped with inline adjusters. Adjust the Defrost, Face / Heat door, and Water valve cable so that the full travel of the Control lever, operates the door to its full travel. Make sure that the water valve completely closes when Lever is in the cold position.

The Micro Switch that is mounted on Defrost / heat door is used to turn on the compressor clutch. This will occur when the control lever is in the defrost position. It may be necessary to adjust the thin metal arm on the switch. Make sure that the Clutch Micro Switch is depressed when lever is in the defrost position. This will provide dehumidification of the air, resulting in a faster clearing of windshield.

*After a break in period ( approximately 3 months) it may be necessary to readjust these cables.*

Locate Center Louver Assembly.

Install center louver assembly in place of Center trim bezel previously removed



#8 x 1/2 Screw

Locate in hardware sack kit the Passenger Louver Assembly. Attach over trim panel to the right of glove box using original hardware at the bottom. Pre drill a 1/8" Dia. hole. Use (1) #8 x 1/2 screw.

Original screws



Locate Face Duct and install onto Evaporator using (2) #10 x 5/8 pan head screws.

NOTE: Make sure that S-Clips are properly pushed over outlet flange.



#10 x 5/8 screw

### CONTROL CABLE AND ELECTRICAL ROUTING

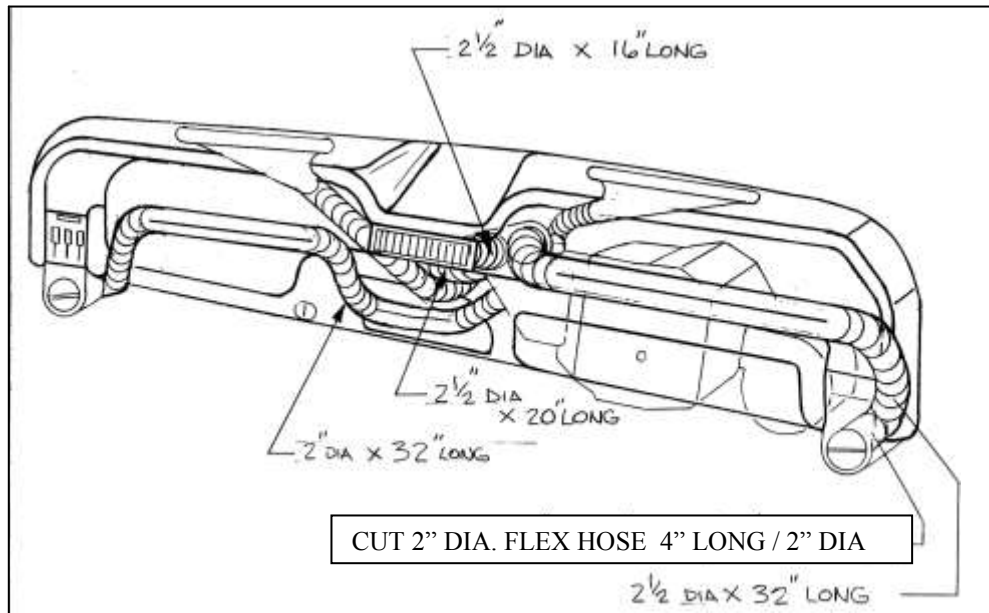
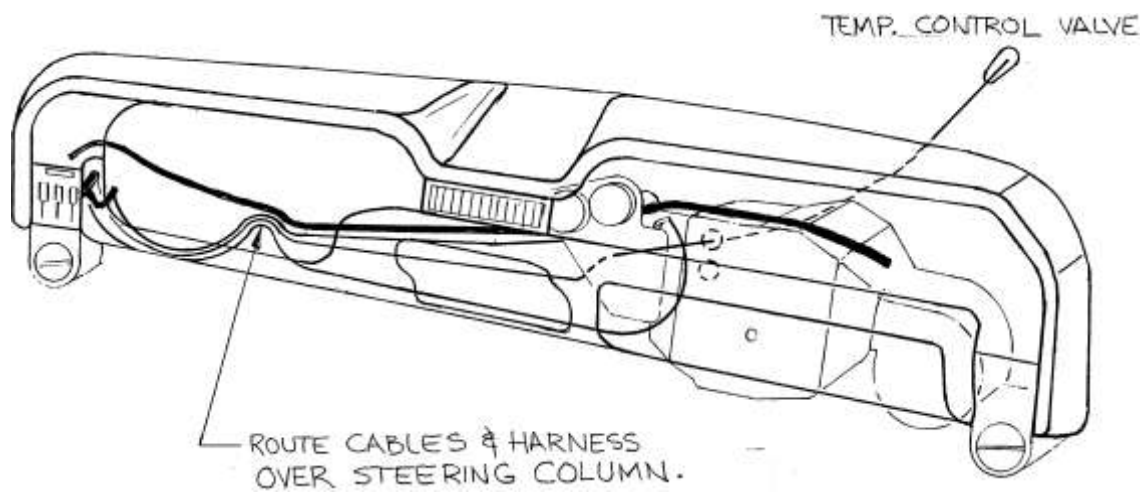

### FLEX HOSE HOSE ROUTING

CUT 2" DIA. FLEX HOSE 4" LONG / 2" DIA



Locate the remaining Flex hose and (2) 2 1/2" oval snap in hose adaptor provided in kit. Attach adaptor to the 2 pieces 2' flex hose. Attach one end to the Face Duct as shown and snap in adaptors to the center louvers.

**Caution:** Carefully check under instrument panel for all cables, electrical harness, or flex ducting that might interfere with safe operation of the vehicle. Make sure that you cycle the Windshield Wipers to insure proper clearance of mechanism.

Reinstall Glove box, Ashtray, and Radio (with bezel). If vehicle is equipped with center console, Modify as shown and reinstall.

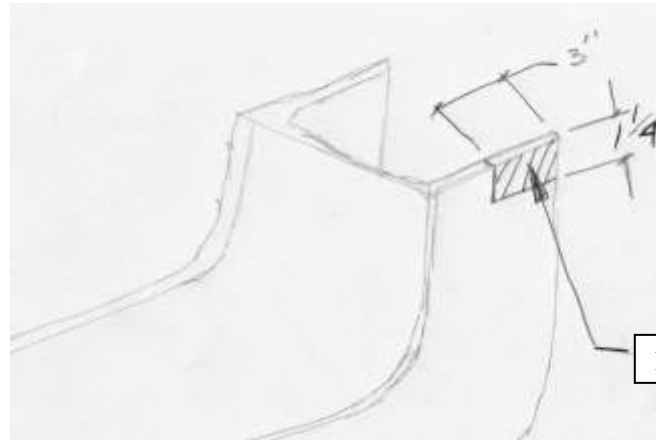

Locate in the Condenser kit the Drier, Drier Mounting bracket, pressure switch kit, Liquid Tube, (2) #10 tek screws, and (2) #6 o-rings.



To locate the drier use the liquid tube from firewall to the spring tower as shown. Attach using (2) #10x 3/4" tek screws.

Install tube using the (2) #6 o-rings and few drops of mineral oil.

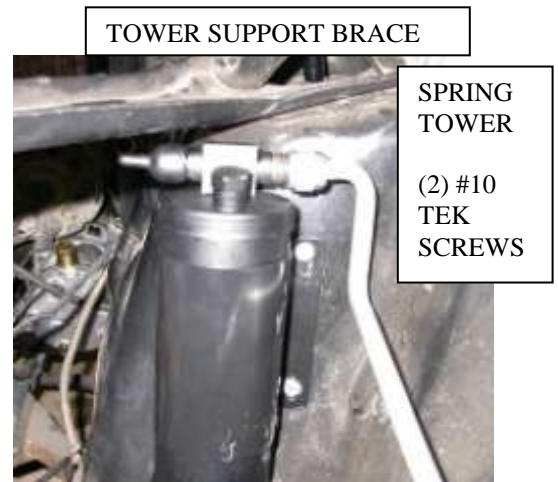



Attach the pressure switch to the top of the drier using a few drops of mineral oil.

INSTALL COMPRESSOR AND MOUNTING HARDWARE USING INSTRUCTIONS SUPPLIED WITH KIT. BE SURE THAT COMPRESSOR ON V8 ENGINE IS INSTALLED WITH FITTINGS 90 Deg. FACING DRIVERS SIDE FENDER

Remove the following components: Center Hood Latch Assembly, and (2) horns. Set aside for reinstallation.

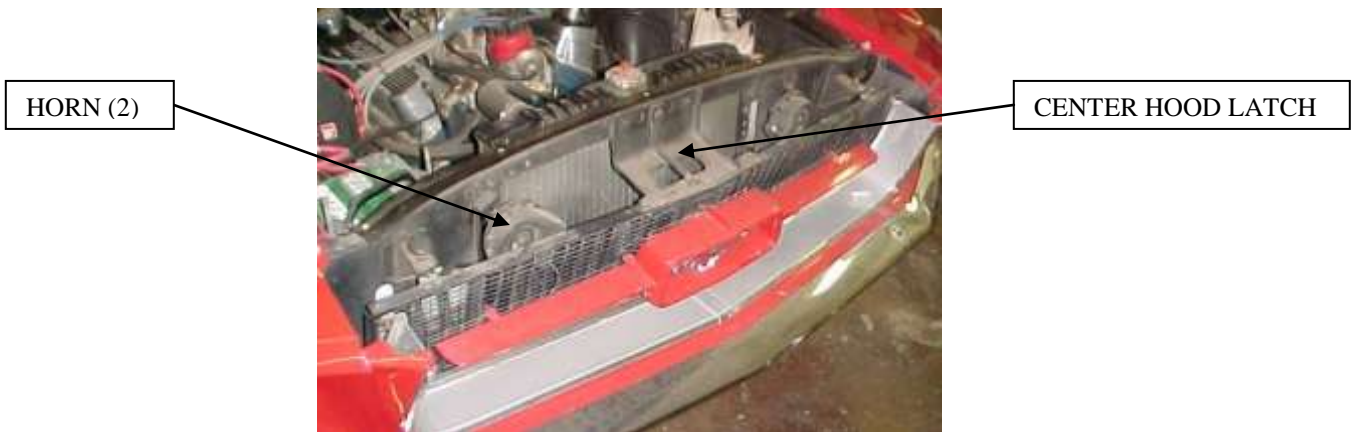

Locate the Condenser Coil, and liquid tube assembly. Attach tube to the coil as shown using (1) #6 o-ring and a few drops of mineral oil.

Locate (2) top and (2) lower condenser mounting brackets, and (8) #10 x 3/8" HWH screws.

Loosely attach brackets to condenser as shown.

**Note:** Tube must be parallel to condenser.



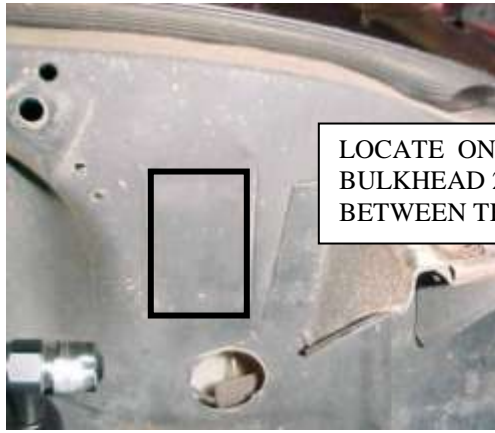

LOCATE ON DRIVERS SIDE OF RADIATOR BULKHEAD 2 PRECUT PUNCH OUTS. CUT BETWEEN THE LINES AS SHOWN.

Slide Condenser Assembly into place as shown. Insert the liquid tube through the hole previously cut. The upper attachment brackets should line up with holes already in radiator support. Attach using (2) #14 x  $\frac{3}{4}$ " tek washer head screws.



Attach the lower brackets to the body using (2) #10x  $\frac{3}{4}$ " tek screws.

Tighten the (8) #10 screws on the condenser coil.



ATTACHMENT LOCATION



Locate the discharge tube and (1) #8-o-ring. Attach to the condenser using a small amount of refrigerant oil on the fitting.



Reinstall the following components: Center Hood Latch Assembly, and (2) horns.



Locate the Tube Support Bracket and install between the Discharge and Liquid tube as shown.

DISCHARGE HOSE

LIQUID HOSE

Locate the long Liquid Hose. This hose has a Straight and a 45 Degree Fitting pre crimped into position.

Loosely attach the straight end of the hose to the liquid tube, the 45 Degree end should be attached to the drier mounted on the spring tower. Attach using (2) #6 o-rings and a few drops of mineral oil. Tighten all fittings.



## VEHICLES WITH V8 ENGINES:

Attach the discharge hose assembly to condenser and then to compressor.

Attach using (2) #8 o-ring using a few drops of mineral oil.

Locate the Suction Hose. The hose has (2) 90 Degree fittings pre-attached in the correct position. One of the ends has a service fitting, this should be attached to the compressor.

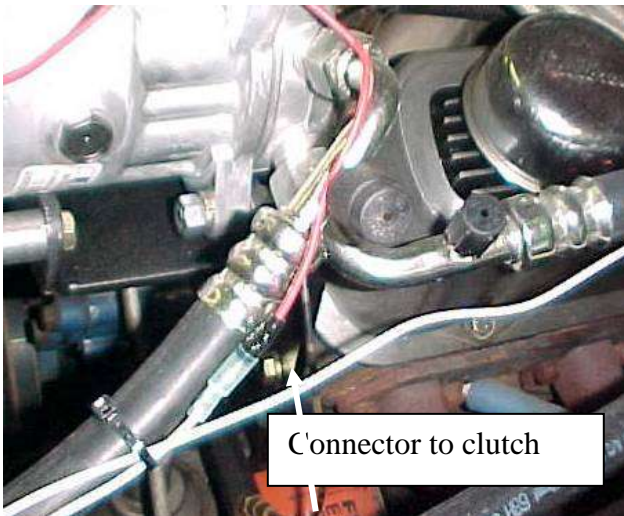

The other end will attach to the suction tube coming from the evaporator assembly. Check for o-rings and apply oil before attachment. Tighten all fittings.

Locate female bullet connector that is supplied with the Hi-Low pressure switch.

Cut one of the white wires from the pressure switch. Attach bullet connector to this wire and plug into the compressor clutch wire.

As shown route the long white wire from the pressure switch along the suction hose and connect to the clutch wire that was inserted through firewall.

Ty-rap suction and liquid hose to the spring tower support.



## VEHICLES WITH 6 CYL. ENGINES.

Attach the discharge hose assembly to condenser and then to compressor.  
Attach using (2) #8 o-ring using a few drops of mineral oil.



Locate the Suction Hose. Attach hose with 90 Degree fitting with service port to the compressor.

The other end will attach to the firewall. Use (2) #10 o-rings and a few drops of mineral oil.

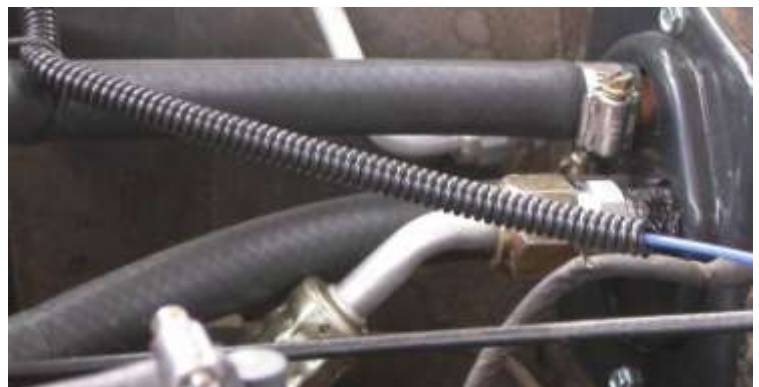

Ty-rap liquid hose to the spring tower support.



***THE ENGINE COMPARTMENT OF YOUR SYSTEM IS COMPLETE.  
THE UNIT IS READY FOR EVACUATION AND CHARGING.***

***THIS SHOULD BE DONE BY A QUALIFIED AND CERTIFIED AIR  
CONDITIONING TECHNICIAN.***

***NOTE: COMPRESSOR IS SUPPLIED WITH THE  
CORRECT OIL CHARGE. DO NOT ADD OIL TO SYSTEM.***

***134a SYSTEMS     24 oz OF REFRIGERANT***

***Recommend that power fuse is 25 amp minimum***

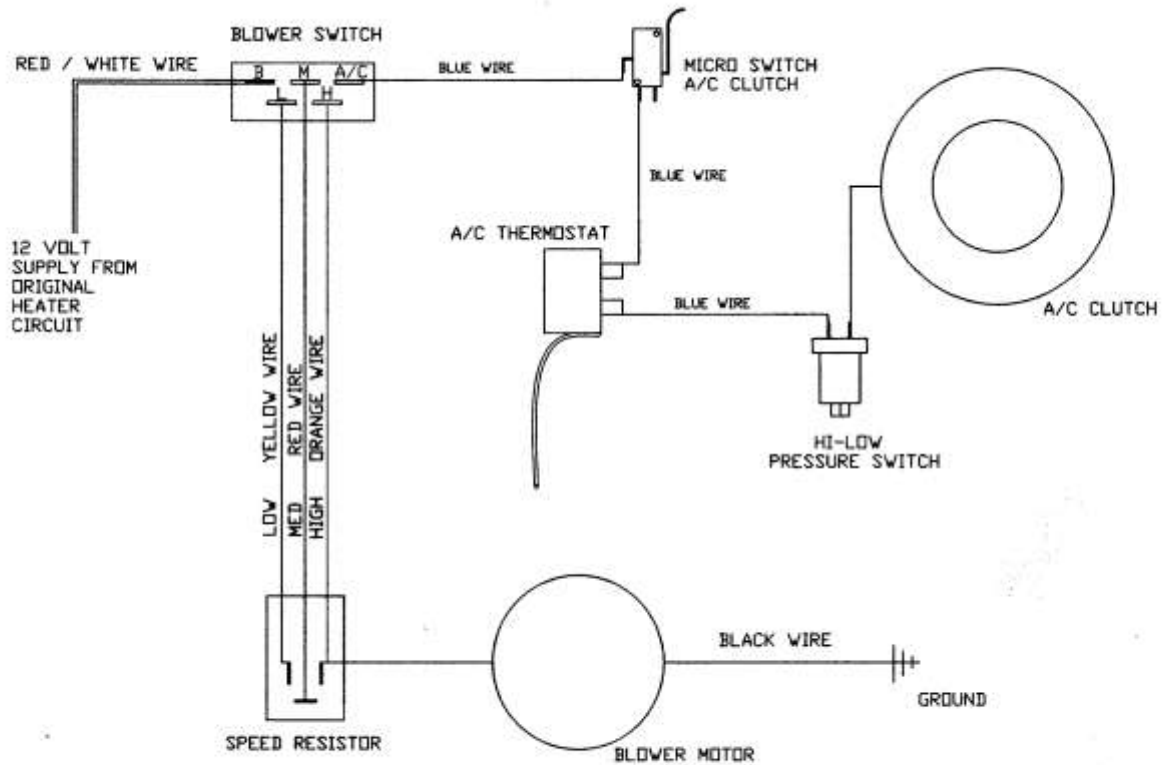

WIRING DIAGRAM 1965 THRU 1968 MUSTANG



# **IMPORTANT**

**CAUTION: WATER VALVE MUST BE INSTALLED PER THE INSTRUCTIONS.**

Classic Auto Air has done extensive testing on the correct method to install the water valve in order to get a repeatable and progressive temperature control.

Locate the **bottom** connection from the evaporator/heater unit off of the firewall and attach a 6" piece of 5/8" dia. heater hose with the supplied hose clamp. Next attach the inlet side of the water valve using another supplied hose clamp, (make sure the arrow on the water valve points toward the engine) Attach a heater hose from the outlet side of the water valve and route to the connection on the water pump.

**NOTE: WATER VALVE = WATER PUMP**

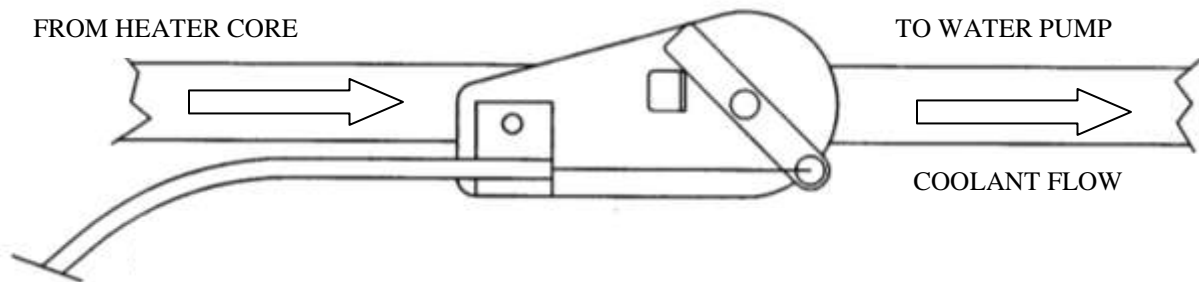

**CAUTION: WATER VALVE MUST BE INSTALLED ON HEATER LINE ROUTED TO WATER PUMP.**

***NOTE: COMPRESSOR PURCHASED WITH KIT IS SUPPLIED WITH THE CORRECT OIL CHARGE. DO NOT ADD OIL TO SYSTEM.***

***134A SYSTEMS      24 oz OF REFRIGERANT  
Recommend that power fuse is 25amp minimum***