



specializing in “AIR CONDITIONING, PARTS AND SYSTEMS” for your classic

***PERFECT FIT”
IN-DASH***

**HEAT/ COOL/ DEFROST
1963-1967 CHEVROLET CORVETTE**

CONTROL & OPERATING INSTRUCTIONS

The controls on your new “Perfect Fit” system. Offers complete comfort capabilities in virtually every driving condition. This includes Temperature control in all of the modes. This system also provides the ability to blend the air between Face and Heat / Defrost modes.



THE PICTURE YOU SEE ABOVE SHOWS THE CONTROLS IN THE FACE MODE. THIS MEANS THAT THE AIR WILL BE DISTRIBUTED THROUGH THE FACE OUTLETS. THIS ALSO HAS THE TEMPERATURE LEVER IN THE COLD POSITION. WITH THE CONTROLS IN THIS POSITION YOU WILL GET THE AIR THROUGH THE FACE OUTLETS WITH THE COMPRESSOR ON.

CAUTION: ALL OF THE OUTSIDE VENTS MUST BE CLOSED WHEN THE SYSTEM IS IN THE A/C MODE. THIS WILL ALLOW THE A/C SYSTEM TO FUNCTION AT ITS MAXIMUM PERFORMANCE LEVEL.

THE FOLLOWING SUMMARY WILL DESCRIBE EACH OF THE CONTROL LEVERS FUNCTION.

FAN SPEED SWITCH: There are 3 speeds plus Off. When the switch is in the off position it will disconnect the 12V power to the Blower Motor and the A/C Clutch. This will shut down the entire system. When the switch is moved to any of the blower speeds 1, 2 or 3 there is 12V supplied to the Micro-Switch that is mounted on the main housing.

FACE AND FLOOR / DEFROST MODE: When the push pull cable is pulled all the way OUT, it will direct the air to the floor / and defrost ducts. The cable can be moved any position from full in to full out. This will give blend between all distribution outlets.

TEMPERATURE CONTROL: The temperature Knob as shown is in the COLDEST temperature position. As the lever is pulled out the temperature of the discharged air will rise to the HOTTEST point.

Note: The temperature lever will function in any of the modes.

AIR CONDITIONING MODE: The picture shows the Knob in the Face Mode (air-flow out the face outlets).

When the Mode control knob is pushed all the way IN the Air Conditioning is activated the compressor clutch is on. When the compressor is activated the Temperature Lever will control the air from maximum cold through maximum heat.



specializing in “AIR CONDITIONING, PARTS AND SYSTEMS” for your classic

INSTALLATION INSTRUCTIONS 1963-67 CHEVROLET CORVETTE

Congratulations!! You have just purchased the highest quality, best performing A/C system ever designed for you Classic Car. To obtain the high level of performance and dependability our systems are known for, pay close attention to the following instructions.

Before beginning the installation check the box for the correct components.

Evaporator
Defrost Duct Assembly
Drivers Console Panel
Passengers Console Panel
Firewall Block Off
Inlet Block Off
Flex Hose 2”dia. x 2ft. – 4ea.
Flex Hose 2”dia. x 3ft – 1ea
Flex Hose 2”dia. x 4ft – 2ea
Sack Kit Hardware
Sack Kit Control
Glove Box

IMPORTANT INFORMATION

1. Before starting, read the instructions carefully and follow proper sequence.
2. Check condition of engine mounts. Excessive engine movement can damage hoses to A/C, heater, radiator, transcooler, and power steering systems.
3. Before starting, check vehicle interior electrical functions. i.e. interior lights, radio, horn, etc. When ready to start installation, disconnect battery.
4. Fittings. Use one or two drops of lubricant on O’rings, threads and rear of bump for O’ring where female nut rides. Do not use thread tape or sealants.
5. Always use two wrenches to tighten fittings. Try holding in one hand while squeezing together while other hand holds fitting in position.
6. Shaft seals in a small percentage of compressors will require as much as 3-4 hours run time to become leak free.
7. Compressors supplied in our complete systems are filled with proper amount of oil.
8. Compressor requires technician to hand turn 15-20 revolutions before and after charging with liquid from a charging station before running system. Compressors with damaged reed valves cannot be warranted.
9. Should you have any technical questions, or are suspect of missing, or defective parts, call us immediately. Our knowledgeable staff will be glad to assist you.

**YOU CAN NOW BEGIN THE INSTALLATION
DISCONNECT BATTERY GROUND CABLE AND REMOVE BATTERY.**



BATTERY GROUND CABLE

**CAREFULLY REMOVE THE HOOD
FROM THE CAR AND SET ASIDE.**



Open glove box and remove (6) screws as shown.
Retain original hardware.

Close glove box door.
Located under the door are (4)
screws. Remove and retain
hardware.

Remove glove box assembly and
set aside for later modification.

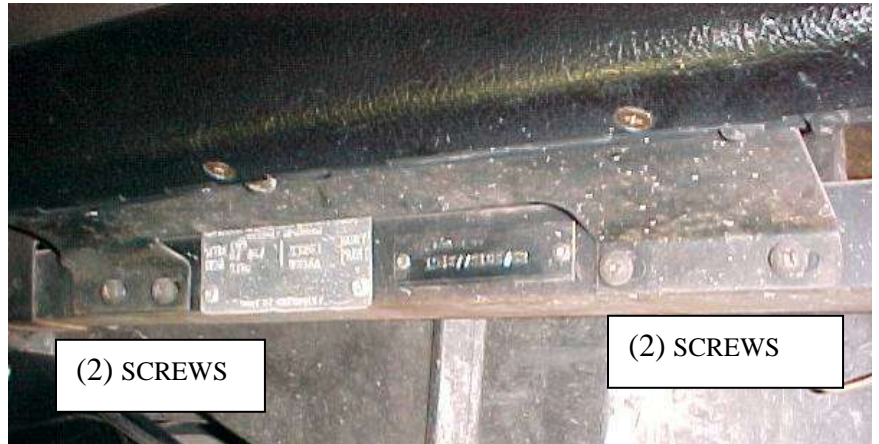

1967 Corvettes have the vent control as shown.

Locate the passenger side panel on the console.
Remove and retain the screw.

Loosen set screw on the knob. Remove and retain
knob.

Remove nut that holds the cable to the panel.
Remove cable from the panel. Retain original
hardware.

NOTE: DRIVERS SIDE PANEL.

REMOVE KNOB AND CABLE USING THE
SAME PROCEDURE.



Locate blower switch and cable assembly just above
the radio. Pull knob out and using a small screw
driver, loosen the set screw in the knob.

Remove and retain knob and set screw for later
reinstallation.

Locate Air / Heat knob just to the right of the blower switch.

This can be removed by turning counter clockwise. The knob screws on to the shaft.

Using a pair of needle nose pliers remove the nut from both of the cables.

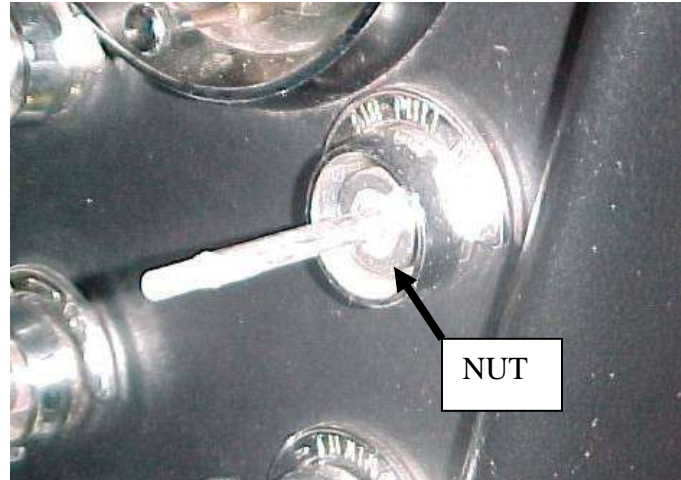

Locate heat/ defrost cable behind the radio and remove the screw.

Remove and discard the cable assembly.



Locate behind the glove box and on top of heater the temperature cable.

Remove the screw and disconnect the electrical plugs at the switch there is a single plug with a brown wire. This is the power wire for the heater. Label this wire.

Remove and discard the cable assembly.

Locate the power wires from original switch.

Wires will be routed over the back of the heater box and attached to the resistor. Disconnect the resistor and cut wires at the end of the electrical tape as shown.

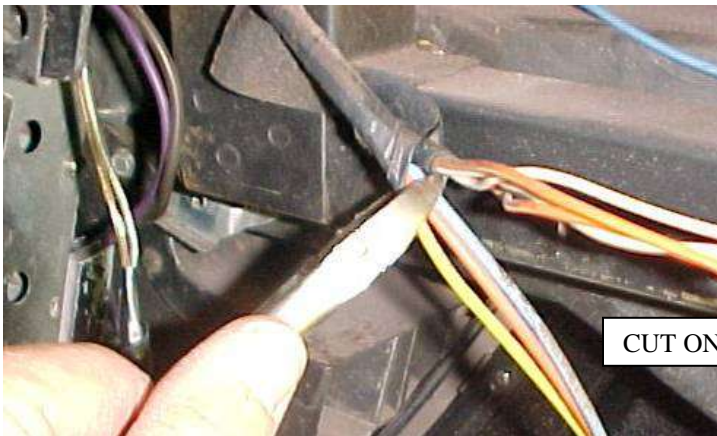
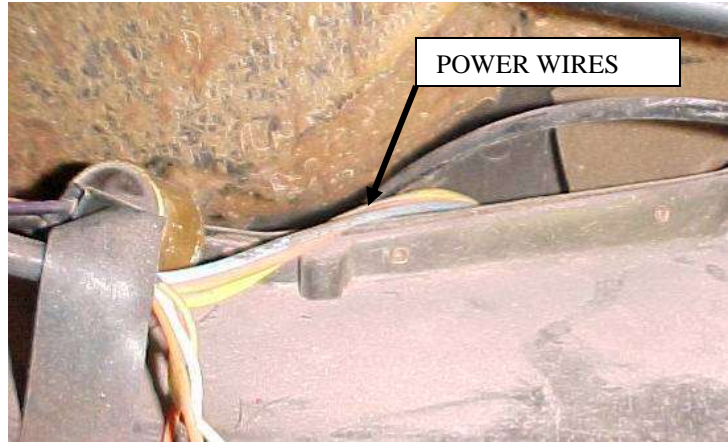

Locate on drivers side of the heater assembly the nut that supports the heater.

Remove and discard this nut.



Located on engine side of the firewall is the blower assembly. Remove (6) nuts around outside of the housing. Disconnect the electricals to the motor. Drain radiator and disconnect heater hoses



Remove the blower housing assembly and discard along with original hardware.

Remove the heater assembly from behind the glove box.

Discard the heater.



Locate defrost duct under the center of the dash.

Remove and discard the duct assembly. Retain the original hardware.





Locate the Defrost Diffuser and the original hardware.

Attach defrost duct using the original nuts.

The next few steps would best be completed with the following specific tool's in order to complete the modifications correctly.

- 1) 1/8" thru 1/2" step drill.
- 2) 9/64" dia. drill bit.
- 3) 8-32 thread tap.



Locate the original blower switch knob.
Remove the set screw and discard.



Carefully clamp knob in a vice and open the hole in the back using a 1/4" diameter drill bit. Drill the hole 7/16" deep.



Locate the original cable control knob.
Carefully clamp knob in a vice and open the hole in the back using 13/64" diameter drill bit. Drill the hole 7/16" deep.

The hole will be tapped for a #8-32 set screw.
With knob still in the vice, drill a hole 9/64" dia thru to the center.



Locate the #8-32 thread tap and thread the hole.

There are (2) #8-32 set screws provided. Insert into the blower and cable control knobs.

Locate (2) Bezel rings from the original controls.

Carefully clamp in vice and open the hole to 7/16" diameter.



Locate the original outside trim bezel.
Locate a piece of wood and clamp it in the vice.

Place trim ring over the edge and open the hole. Using the step drill to 7/16" dia.

Locate a small round file. Carefully remove the flat on bottom of (2) holes where the original controls were mounting.



Using the step drill open both holes to 7/16" diameter.



21" 42" 18"

Locate the Evaporator and set it on the bench.

Locate the 2" diameter flex hose. The hoses should be 2ft x 2ea. and 4ft x 1ea. Be sure that the hose is stretched firmly when cutting to length.

Cut (3) pieces to the following lengths. 18", 21", and 42".

Attach 21" piece to the left rear hose adapter. Use (1) #10 x 5/8" pan head screw.

Attach 42" piece to the center rear hose adapter. Use (1) #10 x 5/8" pan head screw.

Attach 18" piece to the right rear hose adapter. Use (1) #10 x 5/8" pan head screw.

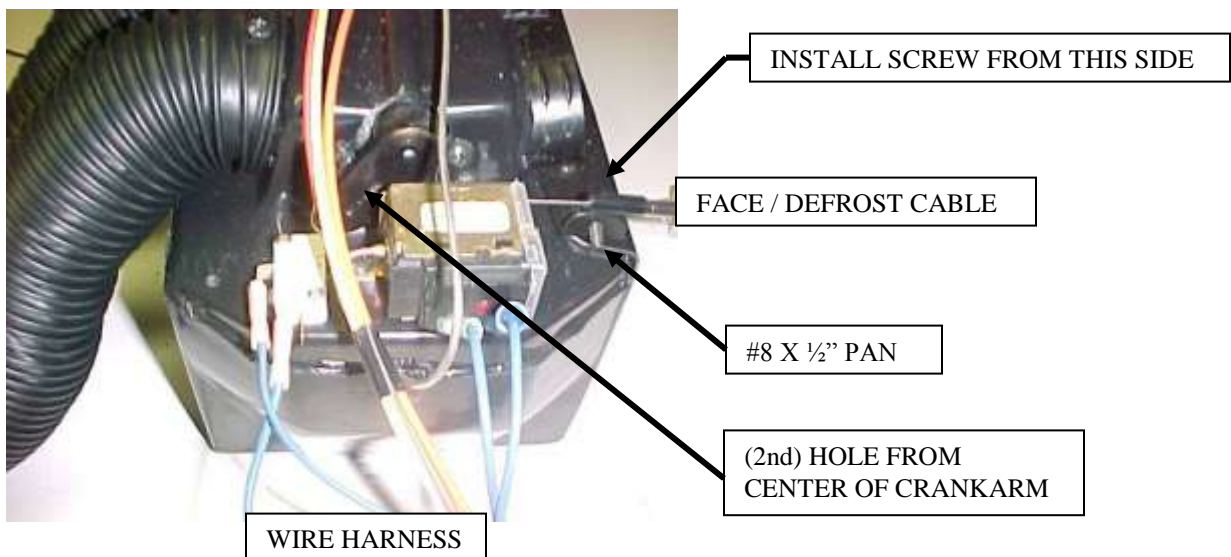

Locate the control cable assembly, (1) #8 x 1/2" pan head screw, and wire harness supplied in kit.

Attach control cable assembly to the evaporator. Insert offset end of the cable into the 2nd hole from the center pivot. Attach cable clip to the unit using (1) #8 x 1/2" pan head screw.

Attach wire harness to the unit using wiring diagram.

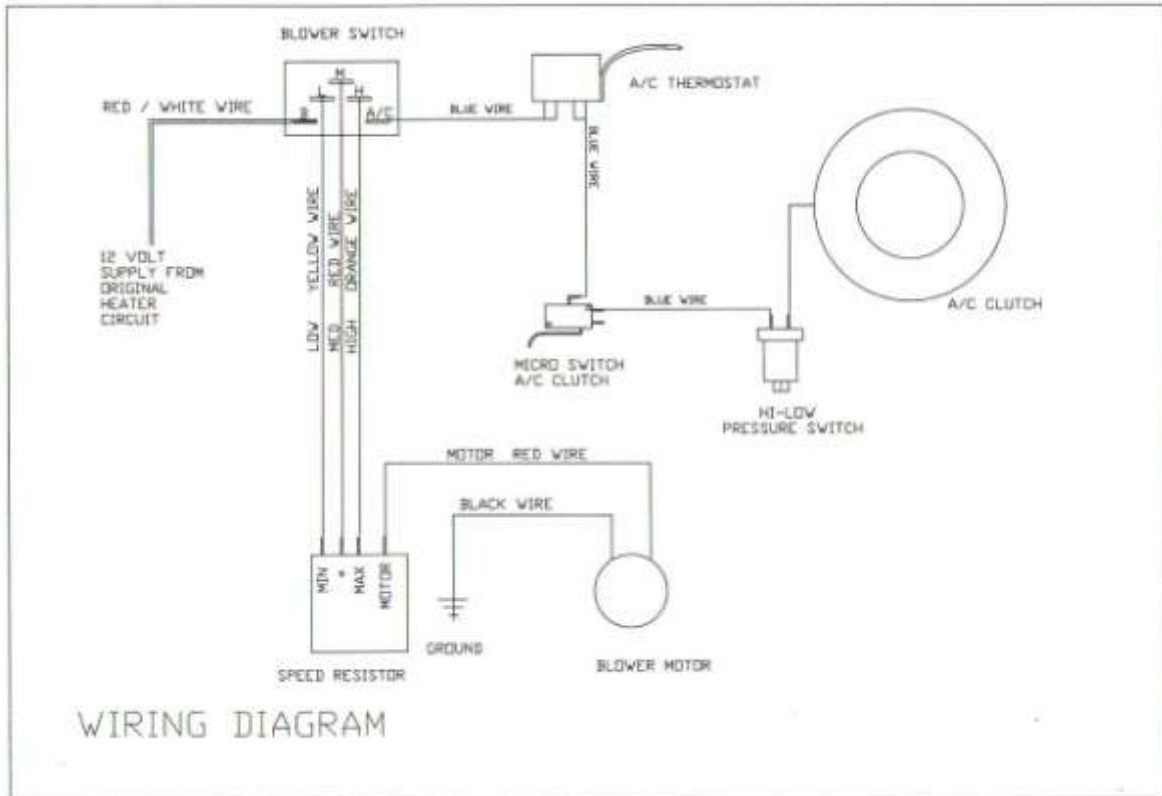

Place evaporator on floor under the glove box.

Route electrical harness across top of the console to drivers side.

Route control cable assembly up and over the dash support brace and out through the glove box opening.

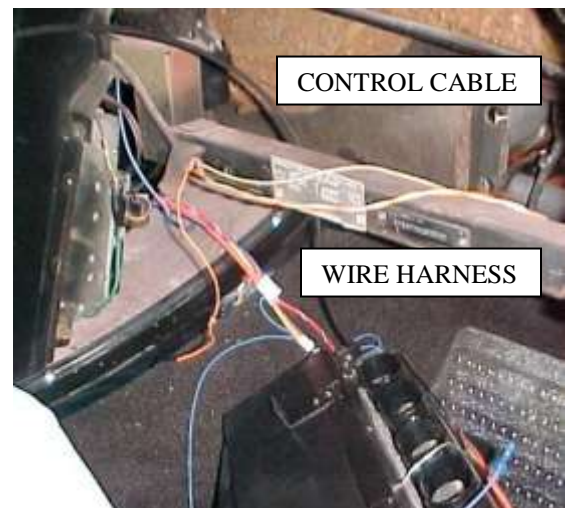



Lift evaporator up and into position.
Attach to the horizontal brace using
(2) #10 x 3/4 hex head tek screws provided.

Route flex hose from rear of the evaporator
behind unit and over to the center of the
vehicle.

Attach the 18" and 21" flex hose to the defrost
diffuser and secure using (1) #10 x 5/8" pan
head screw for each hose.

The 42" hose route to the drivers floor.

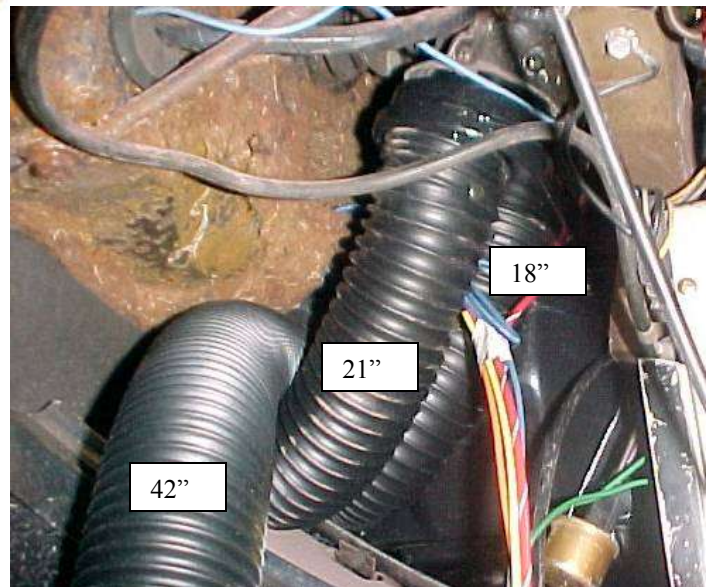

Locate in the hardware sack kit the rear
heater mounting bracket assembly, and
(2) 1/4"-20 x 5/8" hex head screws and
1/4" flat washers.

Attach to the rear of the evaporator as
shown.

Locate in the unit box the inlet air block off.

Using the original nuts attach over the inlet hole as shown. tighten securely.

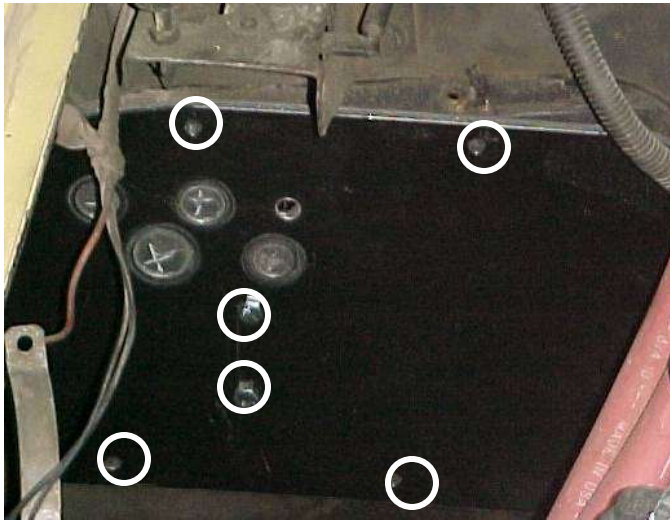

Locate the firewall block off supplied in kit. Also in the hardware sack kit (2) $\frac{1}{4}$ "-20 x $\frac{5}{8}$ " hex head screws, (4) $\frac{1}{4}$ "-20 x 1" hex head screws, and (4) $\frac{1}{4}$ "-20 flange nuts.

Place block off over the hole on the firewall. Attach to the rear heater mounting bracket using (2) $\frac{1}{4}$ " - 20 x $\frac{5}{8}$ " hex head screw. Do not tighten at this point.

Attach block off to the firewall using (4) $\frac{1}{4}$ "-20 x 1" hex head screws and flange nuts.

Tighten all screws securely.

THE NEXT FEW STEPS ARE LOCATED INSIDE THE CAR.

Locate in the hardware sack kit the heat diffuser, and (2) #10 x $\frac{3}{4}$ " tek screws.

Attach diffuser to drivers side kick panel as shown.





Locate 42" flex hose from the drivers floor and attach to heat diffuser using (1) #10 x 5/8" pan head screw.

Locate a tywrap and attach to the vent cable as shown.

Locate on the evaporator the control cable assembly.

Route cable down and loop it up, insert cable through the hole in the instrument panel.

Locate the Trim Bezel, Bezel Ring, and the Knob / Set Screw.

Attach assembly to the instrument panel as shown in the diagram below.

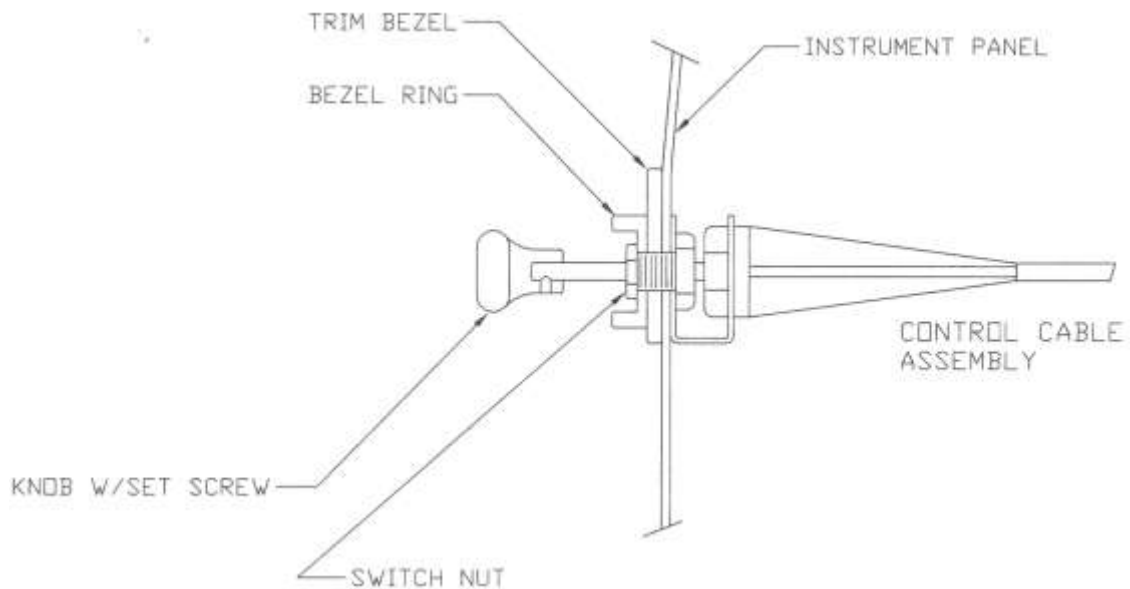



Locate in the control sack kit the blower switch. Also locate Trim Bezel, Bezel Ring and the Control Knob.

Locate wire harness from behind the radio. Attach wires to the switch using the wiring diagram on page 10.

Attach through drivers side hole using same method as the control cable assembly.

Locate on wire harness the red / white wire. Also locate the brown wire from the original harness. Attach a male spade terminal to end of the wire and plug into the red and white wire.

Check original Heater fuse and make sure that it is a 25 amp rating.

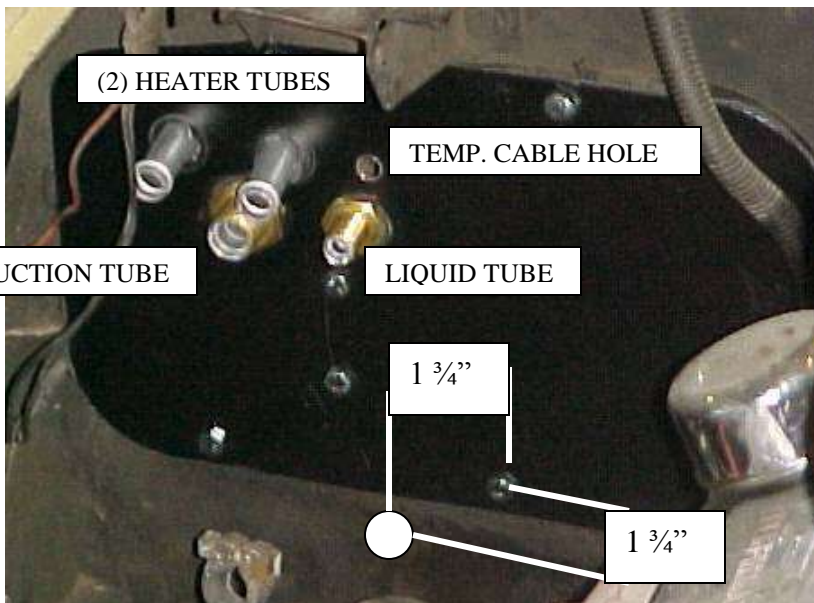
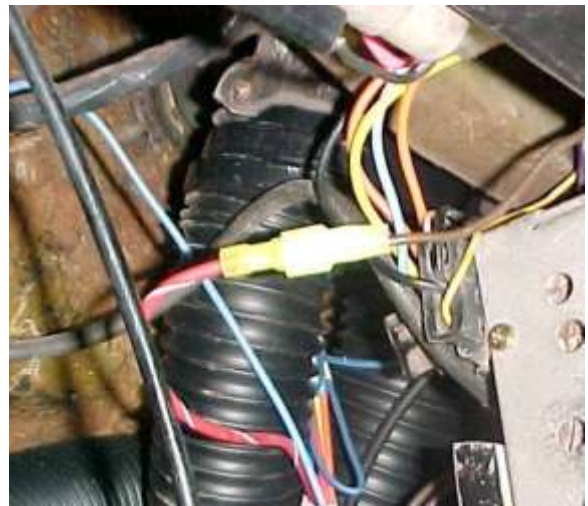

Next few steps will show how the hookup tubes are installed from the evaporator to the firewall block off.

Picture to the left shows locations on the engine side of firewall.

Locate and drill (1) 11/16" diameter hole as shown in the picture to the left.

Locate clear drain tube from the hardware sack kit. Insert through hole and attach to drain nipple on bottom of the evaporator.

Locate in hardware sack kit (2) heater hookup tubes, (2) pieces of 3" long heater hose, and (4) worm gear clamps.

Insert shortest of the tubes through left hole in the block off and attach to rear heater connection using (1) piece of hose and (2) worm gear clamps.

Insert longest of the tubes through right hole in the block off and attach to front heater connection using (1) piece of hose and (2) worm gear clamps.



CAUTION: MAKE SURE THAT YOU HAVE THE CLAMPS TIGHT.

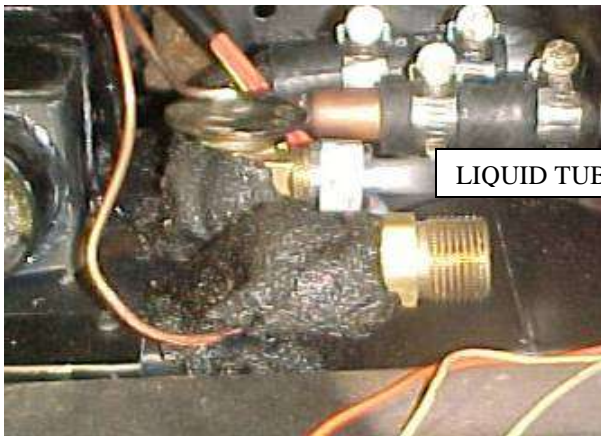

LIQUID TUBE ASSEMBLY

Locate the Liquid Tube Assembly, and (1) #6 o-ring. Insert bulkhead fitting through smaller of the holes in the block off.

Attach other end of the tube to expansion valve using (1) #6 o-ring and a few drops of mineral oil. Tighten securely.

On engine side of block off attach the nut on the bulkhead fitting.

Locate the Suction Tube and (1) #10 o-ring. Insert bulkhead fitting through last hole in the block off.

Attach other end of tube to the evaporator fitting using (1) #10 o-ring and a few drops of mineral oil. Tighten securely.

On engine side of block off attach the nut on the bulkhead fitting.



NOTE: LOCATE REFRIGERANT TAPE FROM THE HARDWARE SACK KIT.

WRAP ALL EXPOSED METAL SURFACES ON THE SUCTION TUBE.

Locate black wire from the resistor assembly.
Using (1) #10 x 3/4" tek screw attach to the metal
brace in front of the blower.



Locate 2" dia. flex hose (2) x 2ft, (1) x 3ft and (1) x 4ft. Cut the 2ft hose to 20" long and
The 4ft hose to 42" long.

Attach to the evaporator and route hoses to the locations as shown below.

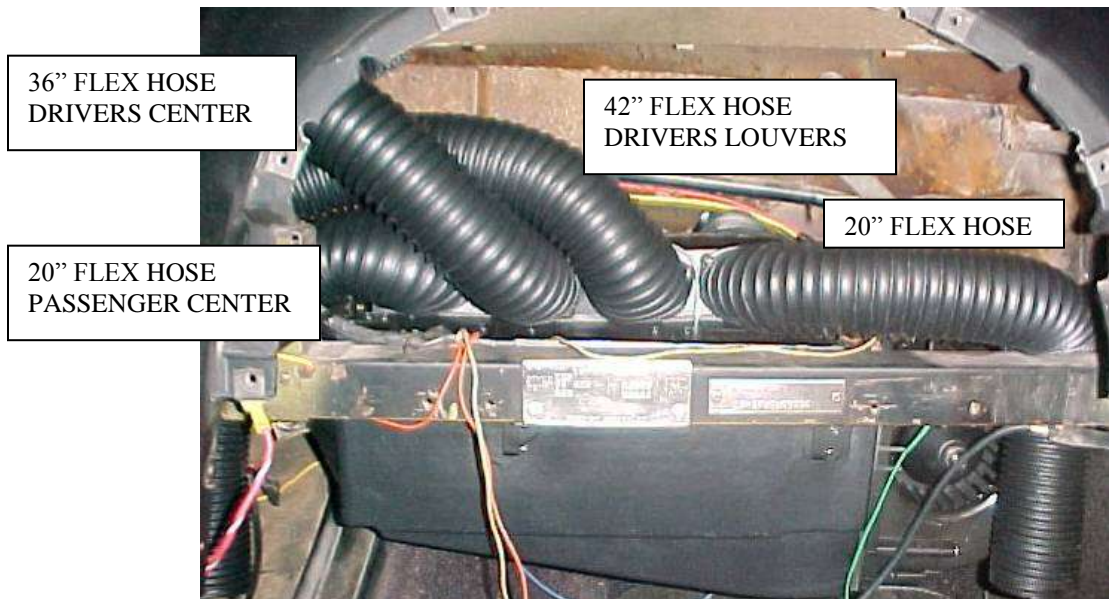

Locate in the hardware sack kit the drivers louver and (2) #10 x 3/4" tek screws.

Remove ball louver and attach louver bezel to bottom of the steering column filler panel.



Reattach the ball louver tighten securely.

Locate passenger center console side panel supplied in kit, and (1) #10 x 5/8" pan head screw.

Attach flex hose from the evaporator to the hose adapter using (1) #10 x 5/8" pan head screw.



NOTE: THE NEXT STEP IS FOR 1967 CORVETTES.



For 1967 Corvettes with the fresh air cables attached to the console cover.

Locate in the hardware sack kit (1) cable mounting bracket and (2) #8 x 3/8" pan head screw.

Attach to bottom of the panel using the #8 screws. Also reuse the original cable nut and knob.

This applies to the drivers side also.

Install right hand console panel to console using original hardware.



Locate drivers side console cover. This one will have the Temperature Control cable attached.

Route temperature control cable across behind radio and between the defrost flex hose and through hole in the firewall block off. See page 14 for location.

Attach the flex hose using (1) #10 x 5/8" pan head screw.

Install side cover using the original hardware.

Locate the original glove box and door assembly.

Carefully remove and discard the original glove box housing. Retain original hardware.

Attach new glove box to the original door frame assembly using original hardware.

Reinstall glove box assembly using original hardware.





Locate in the hardware sack kit the passenger louver and (2) #10 x 3/4" tek screws.

Attach to the glove box support bracket as shown.

Attach flex hose from the evaporator to the hose adaptor.

CAUTION: The control cables are equipped with inline adjusters. Adjust the Defrost, Heat / Face door, and Water valve cable so that the full travel of the Control cable operates the door to its full travel. Make sure that water valve completely closes when the cable is in the cold position.

The Micro Switch that is mounted on the Face / heat door is used to turn on the compressor clutch. This will occur when the control lever is in the face position. It may be necessary to adjust thin metal arm on the switch. Make sure that the Clutch Micro Switch is depressed when lever is in the face position.

The engine compartment components should be installed at this time. Carefully follow the electrical diagram provided on page 10.

NOTE: THE NEXT FEW STEPS ARE FOR THE 24 1/8" & 25 7/8" RADIATOR MOUNTING

Locate following components from the condenser kit. Condenser, filter/drier, hi/low pressure switch, receiver mounting bracket, (2) left condenser mounting brackets, (2) right condenser mounting brackets, condenser to receiver hookup tube, (2) #6 o-rings, and (10) # 10x 3/8" hex head screws.

Attach pressure switch to the drier. Then the drier and mounting bracket using the hookup tube for location to condenser as shown on the next page. Use (2) #10 x 3/8" hex head screws. Use (2) #6 o-ring and a few drops of mineral oil.

Attach condenser brackets to radiator side of the condenser using (2) #10 x 3/8" hex washer head screws for each bracket. Top bracket 2nd hole from the top. Bottom bracket 3rd hole from the bottom.

Attach the liquid and discharge tubes to the condenser assembly using (1) #6 o-ring, (1) #8 o-ring and a few drops of mineral oil.

NOTE: THE NEXT FEW STEPS ARE FOR THE 29 1/2" RADIATOR MOUNTING.

Locate following components from the condenser kit. Condenser, (2) left side condenser mounting brackets, (2) right side condenser mounting brackets, condenser to bulkhead liquid hose assembly, (1) #6 o-ring, and condenser to bulkhead discharger hose assembly (1) #8 o-ring (8) # 10x 3/8" hex head screws.

Attach condenser brackets to radiator side of the condenser using (2) #10 x 3/8" hex washer head screws for each bracket. Top bracket 2nd hole from the top. Bottom bracket 3rd hole from the bottom.

Attach the liquid and discharge hoses to the condenser assembly using (1) #6 o-ring, (1) #8 o-ring and a few drops of mineral oil.

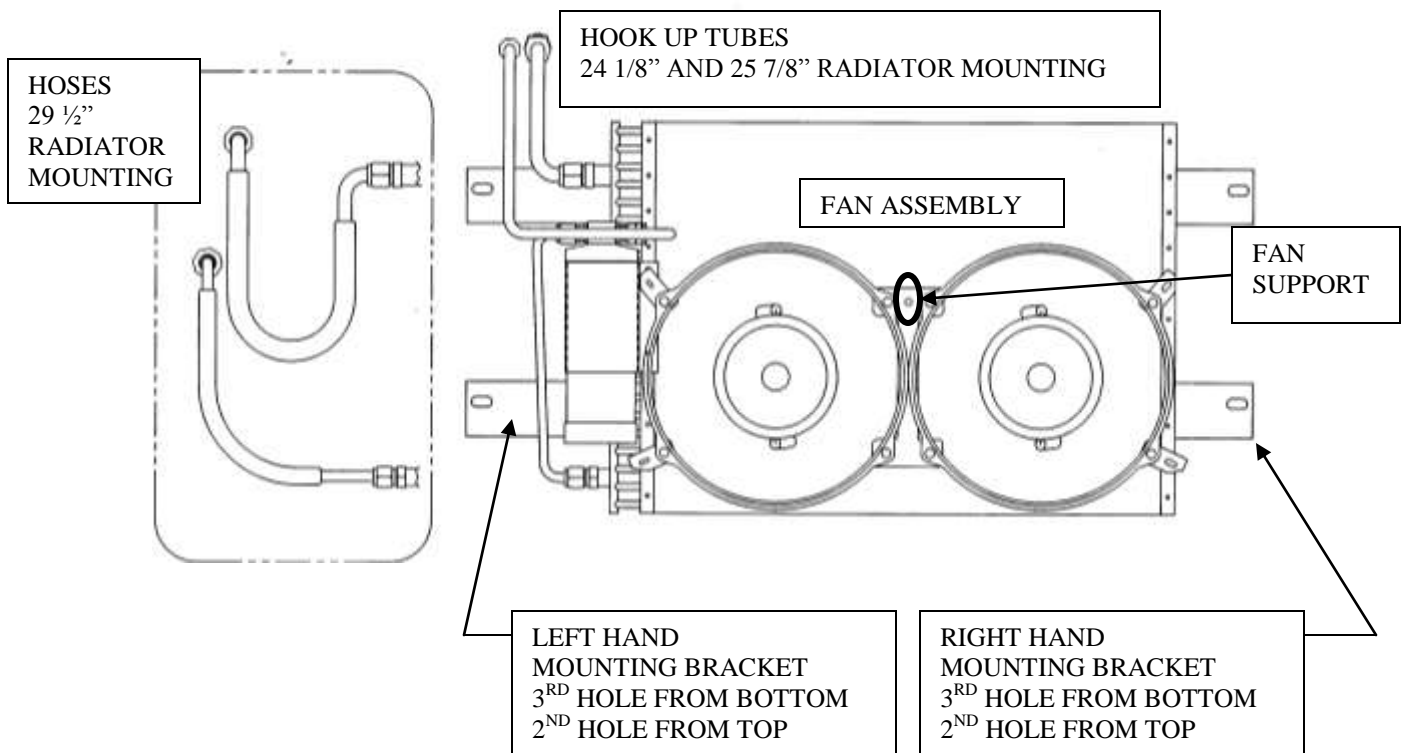

Locate following items from the condenser kit. (2) 9" electric fans, (4) fan mounting brackets, (1) center mounting bracket, (1) push through fan support tydown (2 pads), (3) #10 x 3/8" hex head screws, and (8) 1/4"-20 x 5/8" hex screws and flange nuts.

Attach to the condenser as shown.

NOTE: THE NEXT FEW STEPS ARE FOR THE 24 1/8" & 25 7/8" RADIATORS.

Remove the radiator mounting bolts.

Carefully set condenser assembly in place in front of the radiator bulkhead.

Attach condenser assembly to bulkhead using the original radiator bolts.

Locate the tube support bracket, and (1) #10 x 3/4" tek screw from the condenser kit

Attach the tubes to the bulkhead as shown

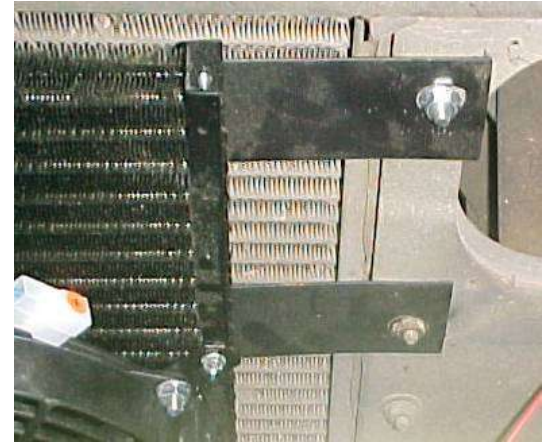
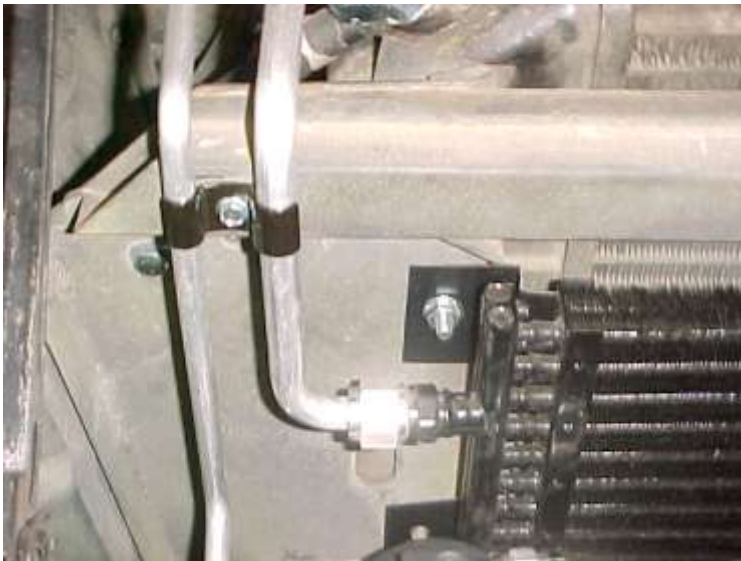

Hookup the heater hoses to the connections coming through the firewall.

NOTE: SUPPLY LINE FROM THE ENGINE WILL BE HOOKED TO THE LEFT FITTING USING A WORM GEAR CLAMP.

Locate in the Hardware Sack Kit the Water Valve and (3) worm gear clamps. Cut 6" off of the return heater hose and attach to connector then to the water valve and then to the remaining hose that goes back to the engine. Use the worm gear clamps supplied.

It is recommended that the heater hoses be replaced at this time.

Locate the Temperature Control Cable and attach it to the water valve as shown. Set cable so that the Temp knob is pushed all the way in and the water valve is in its fully closed position.

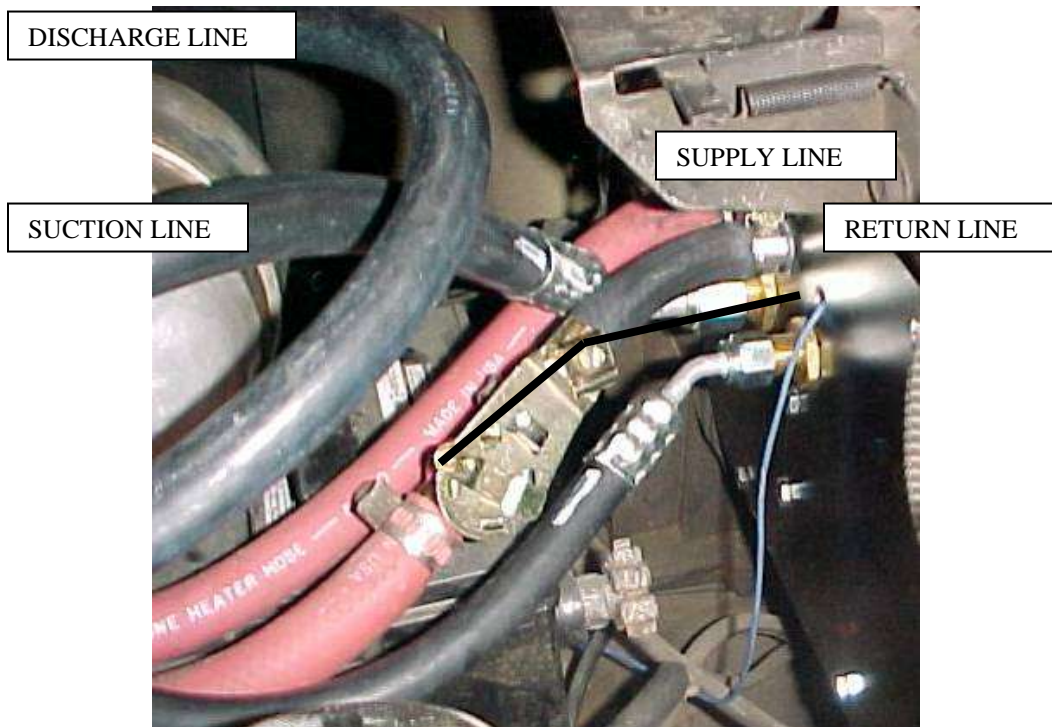

Locate the Liquid Hose and discharge hose.

Attach Liquid hose to the bulkhead tube and route along fender well to fitting on the firewall.

Attach using (2) o-rings and a few drops of mineral oil.



Route discharge hose along fender well, loop it around and attach to rear of the compressor, using (1) #8 o-ring and a few drops of mineral oil.

Locate the suction hose and attach between fitting on firewall and rear of the compressor using (2) #10 o-rings and a few drops of mineral oil.

Route clutch wire from firewall block off to pressure switch along the liquid hose. Attach a flag terminal to wire and plug it onto the pressure switch.

Second terminal on pressure switch goes to compressor clutch and the fan relay harness.

Refer to wiring diagram for proper connections.

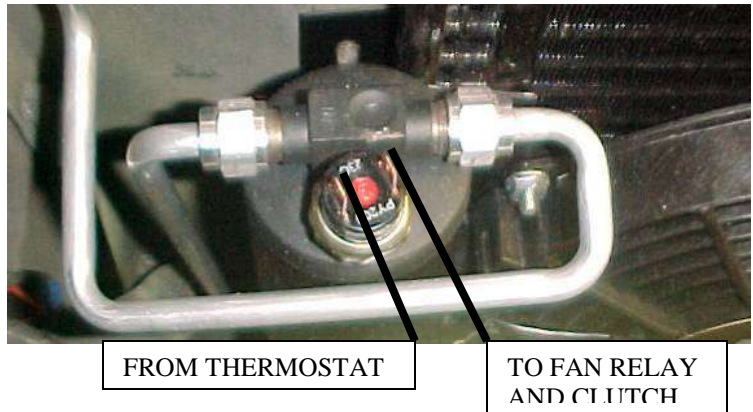

NOTE: THE NEXT FEW STEPS ARE FOR THE 29 1/2" RADIATORS.

Remove the radiator mounting bolts.

Carefully set condenser assembly in place in front of the radiator bulkhead.

Attach condenser assembly to bulkhead using the original radiator bolts.

Locate and drill (2) holes 3/4" dia. for the bulkhead fittings as shown.

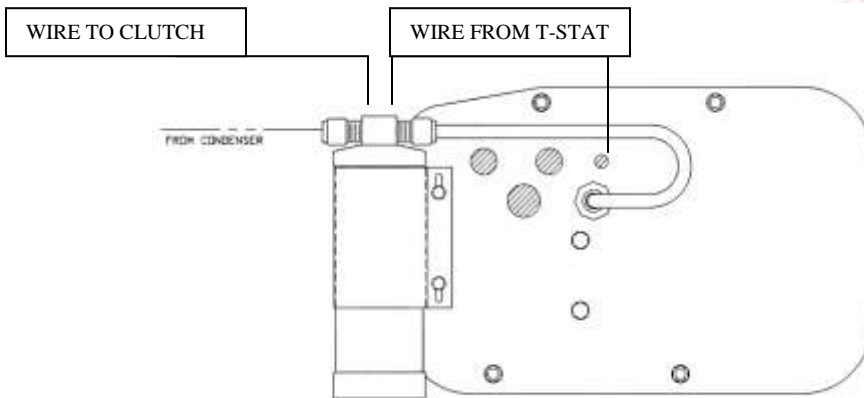

Locate the filter drier, hi / low pressure switch, pressure switch harness assembly, liquid tube (bulkhead / drier), drier mounting bracket, and (2) #10 x 3/4" tek screws. Install pressure switch on filter drier.

Attach filter drier to the firewall block off as shown using the liquid tube for location. Attach tube using (2) #6 o-rings and a few drops of mineral oil. Route blue wire from thermostat and connect to one of the white wires on pressure switch. Route other white wire along suction hose to the compressor.

Locate the discharge and suction hose and attach to the bulkhead fittings as shown on page 22.

Locate the Fan Relay Harness, and
(2) #10 x 3/4" tek screw.

Attach relay to the vehicle close to
the pressure switch. Connect wiring
using the wiring diagram.

On vehicles with (2) fans connect
wires from the fans together and then
to the relay assembly.

Ground black wire on the relay
assembly to mounting tab of the
relay.

The fan ground needs to be attached
with its own screw.

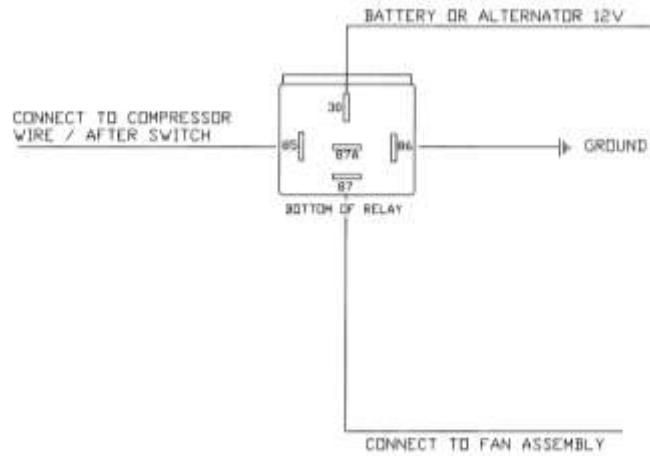

AUXILIARY FAN RELAY / ELECTRICALS

Reinstall the fan shroud, fan assembly, hookup radiator hoses and refill with coolant.

***THE ENGINE COMPARTMENT OF YOUR SYSTEM IS COMPLETE.
THE UNIT IS READY FOR EVACUATION AND CHARGING.***

***THIS SHOULD BE DONE BY A QUALIFIED AND CERTIFIED AIR
CONDITIONING TECHNICIAN.***

***NOTE: COMPRESSOR IS SUPPLIED WITH THE
CORRECT OIL CHARGE. DO NOT ADD OIL TO SYSTEM.***

***134a SYSTEMS 24 oz OF REFRIGERANT
Recommend that power fuse is 25amp minimum***

IMPORTANT

CAUTION: WATER VALVE MUST BE INSTALLED PER THE INSTRUCTIONS.

Classic Auto Air has done extensive testing on the correct method to install the water valve in order to get a repeatable and progressive temperature control.

Locate the **bottom** connection from the evaporator/heater unit off of the firewall and attach a 6" piece of 5/8" dia. heater hose with the supplied hose clamp. Next attach the inlet side of the water valve using another supplied hose clamp, (make sure the arrow on the water valve points toward the engine) Attach a heater hose from the outlet side of the water valve and route to the connection on the water pump.

NOTE: WATER VALVE = WATER PUMP

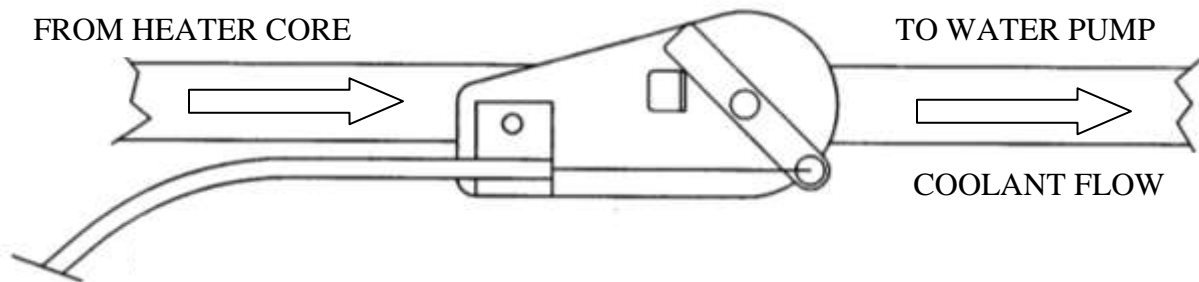

CAUTION: WATER VALVE MUST BE INSTALLED ON HEATER LINE ROUTED TO WATER PUMP.

NOTE: COMPRESSOR PURCHASED WITH KIT IS SUPPLIED WITH THE CORRECT OIL CHARGE. DO NOT ADD OIL TO SYSTEM.

***134A SYSTEMS 24 oz OF REFRIGERANT
Recommend that power fuse is 25amp minimum***