



specializing in “AIR CONDITIONING, PARTS AND SYSTEMS” for your classic

“PERFECT FIT” IN-DASH

HEAT/ COOL/ DEFROST
1957-60 FORD PICKUP

CONTROL & OPERATING INSTRUCTIONS

The controls on your new “Perfect Fit” system. Offers complete comfort capabilities in virtually every driving condition. This includes Temperature control in all of the modes.

This system also provides the ability to blend the air between Face and Heat / Defrost modes.



THE PICTURE YOU SEE ABOVE SHOWS THE CONTROLS IN THE FACE MODE. THIS MEANS THAT THE AIR WILL BE DISTRIBUTED THROUGH THE FACE OUTLETS. THIS ALSO HAS THE TEMPERATURE KNOB IN THE COLD POSITION.

CAUTION: ALL OF THE OUTSIDE VENTS MUST BE CLOSED WHEN THE SYSTEM IS IN THE A/C MODE. THIS WILL ALLOW THE A/C SYSTEM TO FUNCTION AT ITS MAXIMUM PERFORMANCE LEVEL.

THE FOLLOWING SUMMARY WILL DESCRIBE EACH OF THE CONTROL LEVERS FUNCTION.

FAN SPEED SWITCH: There are 3 speeds plus Off. When the switch is in the off position it will disconnect the 12V power to the Blower Motor and the A/C Clutch. This will shut down the entire system. When the switch is moved to any of the blower speeds 1, 2 or 3 there is 12V supplied to the Micro-Switch that is mounted on the duct housing.

TEMPERATURE CONTROL: The temperature Knob as shown is in the COLDEST temperature position. As the knob is pulled out the temperature of the discharged air will rise to the HOTTEST point.

Note: The temperature knob will function in any of the modes.

AIR CONDITIONING MODE: The picture shows the Heat Knob in the A/C Mode (air-flow out the FACE outlets).

When the Mode control knob is in this position the Air Conditioning is activated and the compressor clutch is on. When the compressor is activated the Temperature Knob will control the air from maximum cold through maximum heat.

HEAT MODE: The Heat Knob is shown in the A/C position. As the Knob is pulled out the air will blend to the Heat / Defrost Mode. When the knob is in the this position the Temperature Knob will change the discharge air from full cold through maximum heat.



specializing in “AIR CONDITIONING, PARTS AND SYSTEMS” for your classic

INSTALLATION INSTRUCTIONS 1957-60 FORD PICKUP

Congratulations!! You have just purchased the highest quality, best performing A/C system ever designed for you Classic Truck. To obtain the high level of performance and dependability our systems are known for, pay close attention to the following instructions.

Before beginning the installation check the box for the correct components.

Evaporator

Flex Hose 2”dia. x 1ft. (1)

Flex Hose 2”dia. x 3ft. (2)

Flex Hose 2”dia. x 4ft. (1)

Sack Kit Hardware

Sack Kit Control

Glove Box

IMPORTANT INFORMATION

1. Before starting, read the instructions carefully and follow proper sequence.
2. Check condition of engine mounts. Excessive engine movement can damage hoses to A/C, heater, radiator, transcooler, and power steering systems.
3. Before starting, check vehicle interior electrical functions. i.e. interior lights, radio, horn, etc. When ready to start installation, disconnect battery.
4. Fittings. Use one or two drops of lubricant on O’rings, threads and rear of bump for O’ring where female nut rides. Do not use thread tape or sealants.
5. Always use two wrenches to tighten fittings. Try holding in one hand while squeezing together while other hand holds fitting in position.
6. Shaft seals in a small percentage of compressors will require as much as 3-4 hours run time to become leak free.
7. Compressors supplied in our complete systems are filled with proper amount of oil.
8. Compressor requires technician to hand turn 15-20 revolutions before and after charging with liquid from a charging station before running system. Compressors with damaged reed valves cannot be warranted.
9. Should you have any technical questions, or are suspect of missing, or defective parts, call us immediately. Our knowledgeable staff will be glad to assist you.

YOU CAN NOW BEGIN THE INSTALLATION

CAUTION: DISCONNECT BATTERY GROUND CABLE

Disconnect the battery ground cable. Remove battery and battery tray.

Drain radiator and remove the radiator. Disconnect Heater hoses from heater connections on the firewall.

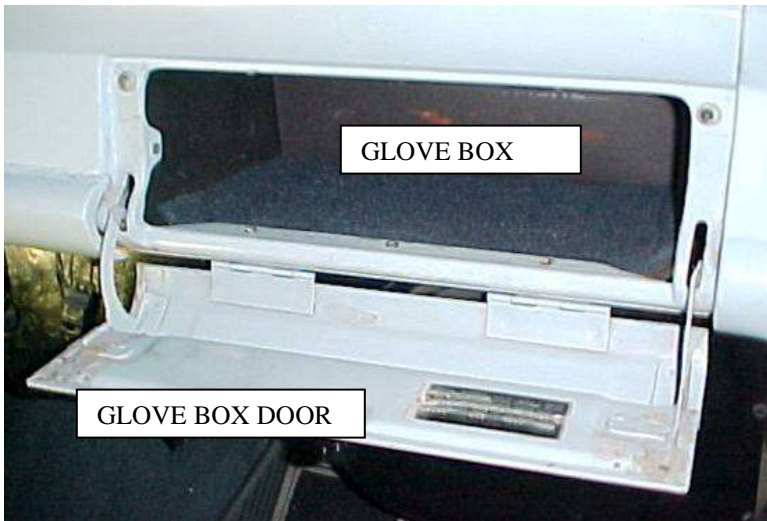

Remove the Glove box. Retain all original hardware. Discard the glove box housing.

The truck will either be equipped with a Standard Heater Assembly, or a Deluxe Heater Assembly.

Locate control cable connected between original switch to the heater assembly. Remove and discard. Disconnect resistor wire assembly, remove and discard. Remove and discard the original blower switch.

Carefully remove the heater box from the firewall. Discard original hardware.



If truck is equipped with the deluxe heater. Remove the fresh inlet flange. Retain original hardware.

Locate in hardware sack kit the inlet block off. Install over inlet hole using original hardware.

Locate in the instructions a Firewall Drill Template. Tape to engine side of the firewall. Locate template to the original holes as shown below.

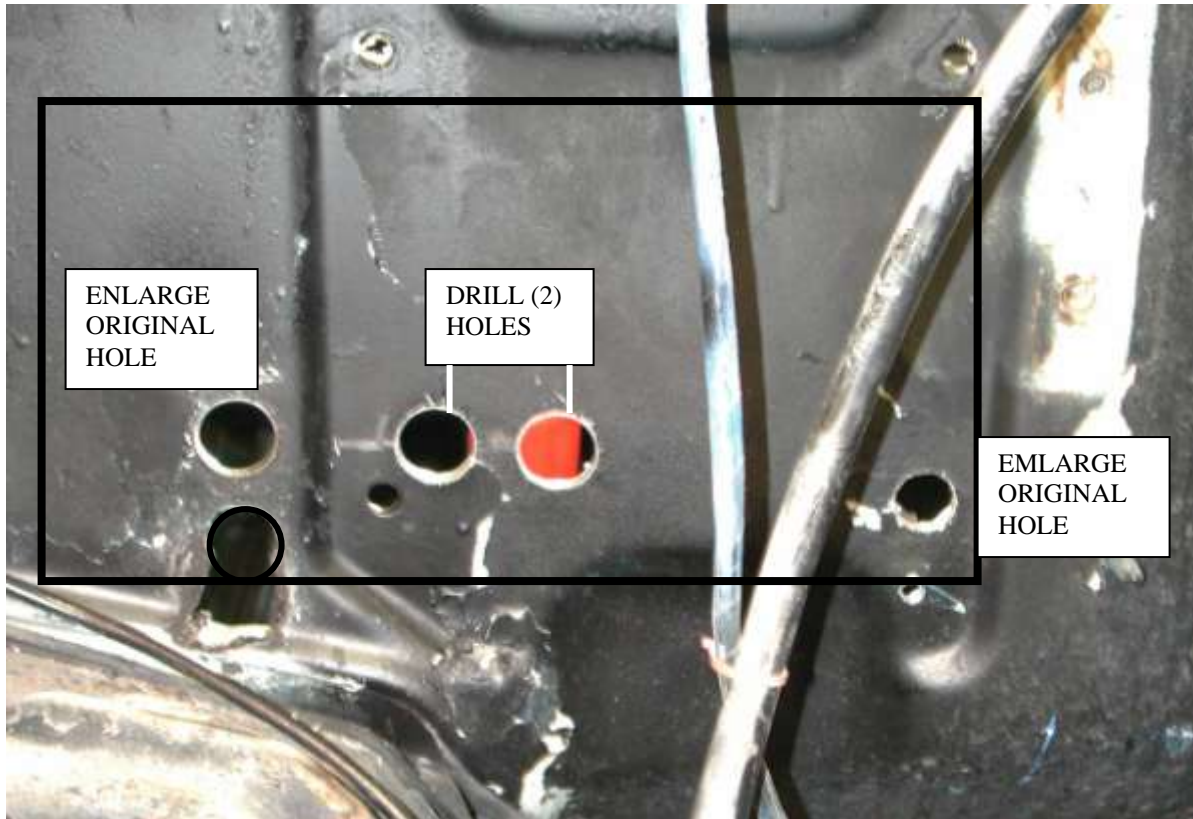

Enlarge original heater tube hole to 1" dia.
Enlarge original heater mounting hole to 13/16" dia.
Drill new heater tube holes to 7/8" dia.

Modifications to the vehicle are complete. You can now begin installing your new Classic Auto Air "Perfect Fit Series" system.



Locate in the unit box (2) Defrost Diffusers, and (2) #10 -32 nuts.

Attach diffusers to under side of defrost outlet slots by inserting the bracket through the slot and using a #10 nut on the original stud.

Locate Evaporator Assembly and Face Duct from the kit. Place on work bench.

Attach Face duct over outlet flange. Be sure that the s-clips attach to flange.



Locate Defrost / Heat duct and (2) #10 x 5/8" pan head screws.

Attach duct to back of the evaporator and onto metal bracket as shown.

Locate (1) #8 x 3/8" pan head screw.

Place unit upside down on bench and fasten together face and defrost / heat duct using the #8 screw.



Locate in control sack kit the wiring harness. Attach to evaporator using the wiring diagram.

Notice (2) ¼ - 20 j- clips on back of the evaporator.

Insert evaporator assembly up and behind the glove box opening.

Line up j-clips with original heater holes in the firewall.

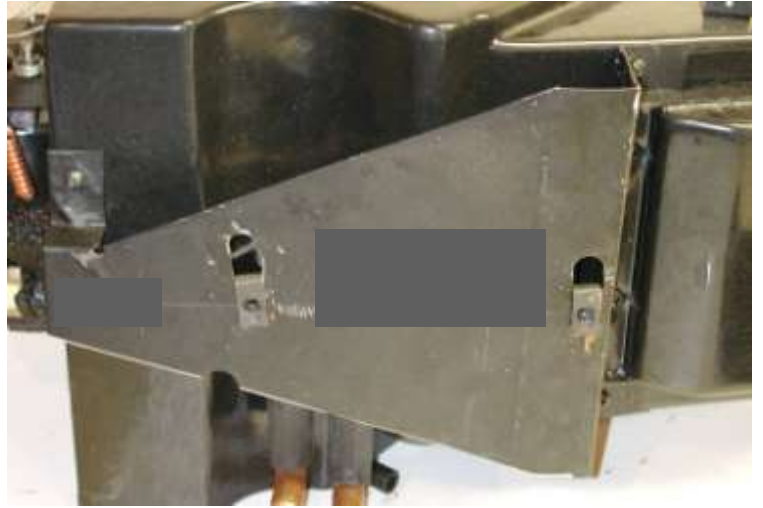

From engine side of the firewall attach unit using (2) ¼" – 20 x 1" hex head screws and (2) flat washers.

Pull the a/c tubes and heater connections through the firewall.





Locate in the hardware sack kit (2) #10 x ¾ tek screw.

Attach Support bracket under glove box opening to bottom of the dash using (1) #10 x ¾ tek screw.

Locate Black wire with Ring Terminal from the blower motor. Attach wire to the body.

Route electrical harness across top of unit and down to center of the cab.



Locate in the hardware sack kit (1) 9" piece of ½" dia. drain tube.

Attach over drain nipple and through the hole previously drilled.

Locate in the unit box the 2" dia. x 3ft. flex hose.

Cut (2) pieces 15" long.

Attach over defrost duct outlets located on the center duct as shown.

Route both pieces of flex hose up and attach to the defrost diffusers.



Locate wire that attached to the original blower switch. Cut off the terminal and attach a ¼” male spade connector.

Locate red / white stripped wire on the wire harness and plug it into the original power wire.

Also locate clutch wire from the thermostat, route over top of evaporator and out through bottom hole that original heater mounted through.

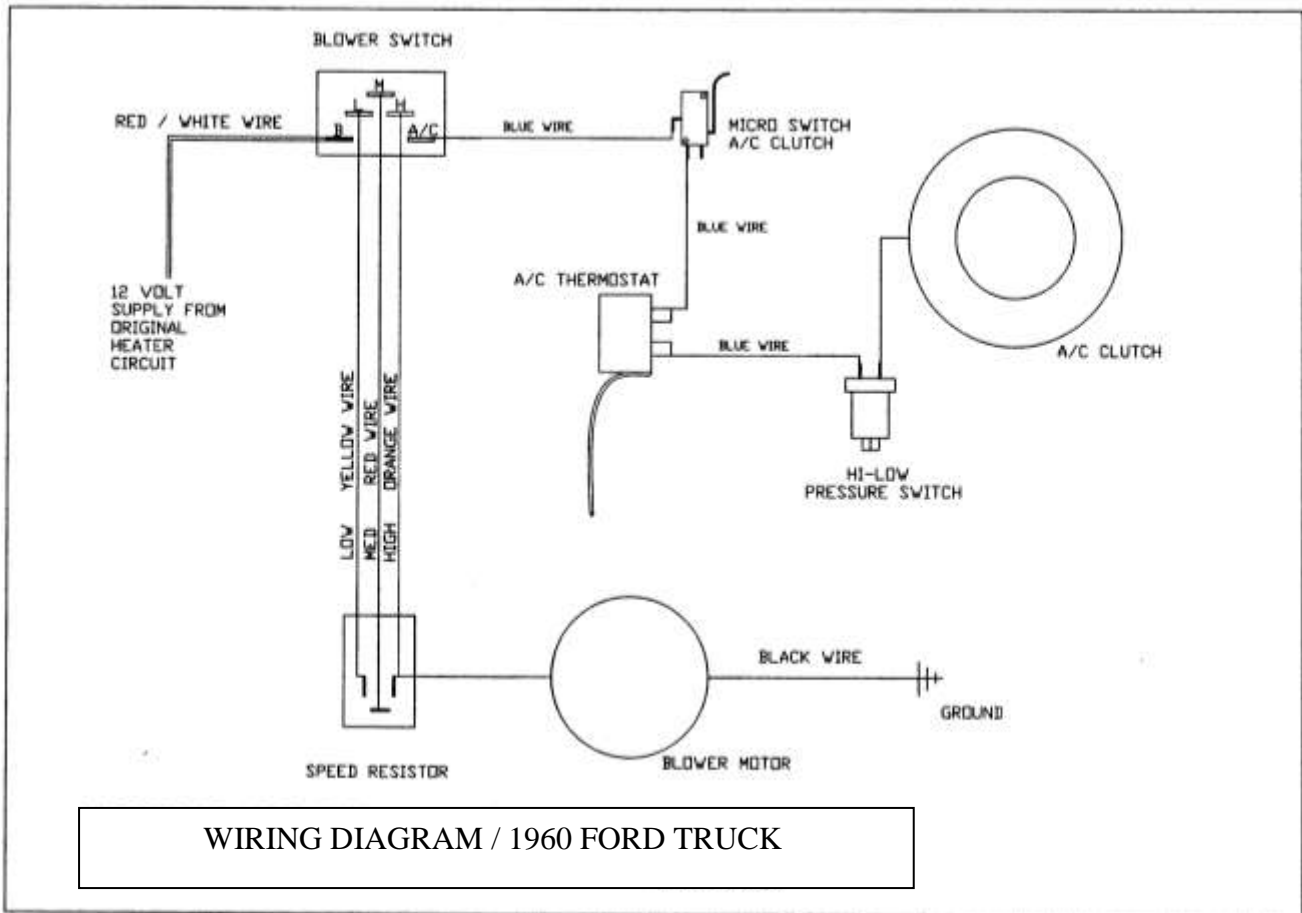

Locate Center Control and Louver Assembly and (2) #10 x ¾” tek screws.

Attach wires from the unit to switch as shown. Refer to the wiring diagram for correct connections.

THIRD HOLE FROM CENTER OF CRANK ARM

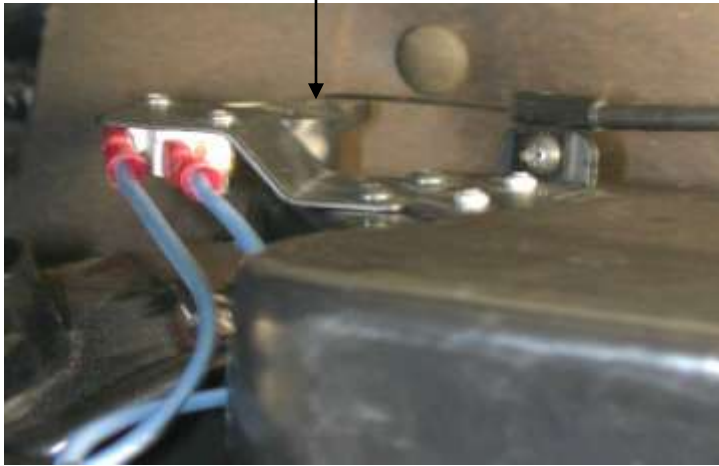

Attach (2) 3/16" spade terminals on blue wires to the micro switch located on top of the unit.

Route the HEAT cable over to top of the evaporator. Attach the cable to bracket using (1) #8 x 1/2 pan head screw.

NOTE: Insert cable in third hole from center of the crank arm.

Attach assembly to bottom of the instrument panel using the (2) #10 tek screws.

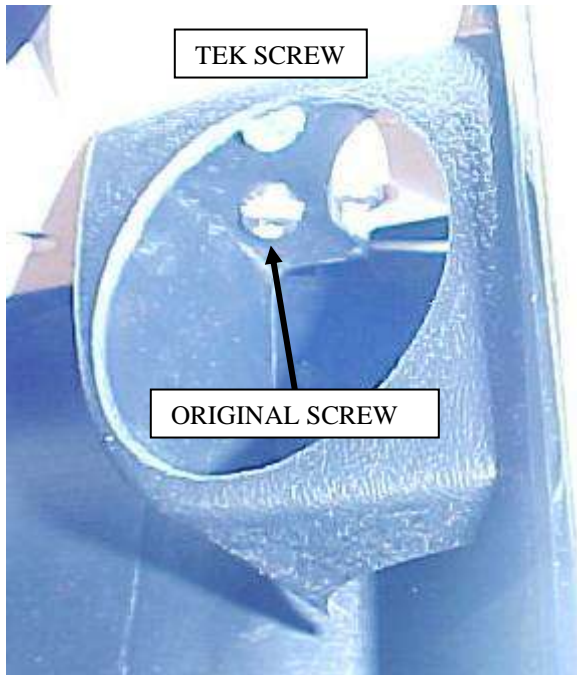

Locate 12" flex hose, attach to center louver and to left outlet on center duct assembly.

Locate in the hardware sack kit. Passenger side Ball Louver and 2" dia. x 36" flex hose

Locate (2) #10 x 3/4" hex head tek screw. Remove Ball Louver from the housing and attach Housing Assembly to bottom of the instrument panel using (2) #10 tek screw through holes in the louver housing.

Reattach ball louver to the hose adaptor.
Attach 36" of flex hose to hose adapter on rear of passenger Louver.

Route flex hose up and over evaporator and attach to right outlet on top of the center duct assembly.



Locate drivers side louver. Remove ball louver and locate 2" dia. x 48" flex hose and attach to hose adapter using (1) #10 x 5/8" screw.

Attach the housing to drivers side instrument panel using (2) #10 x 3/4" Tek screws.

Reinstall the ball louver assembly.

Attach 48" hose to hose adapter on rear of the Drivers Louver Assembly and route up and to the center outlet on top of the center duct assembly.



ORIGINAL HOLE



Locate Temperature Cable attached to the control head. Route this cable along firewall and out through original hole that supported the original heater.



Locate New Glove Box and install into the opening using original hardware.

Install Glove Box Door using the original hardware.

CAUTION: The control cables are equipped with inline adjusters. Adjust the Heat control knob to its full travel. Make sure that the water valve completely closes when cable is in the cold position.

The Micro Switch that is mounted on the Face / heat door is used to turn on the compressor clutch. This will occur when the control lever is in the face position. It may be necessary to adjust the thin metal arm on the switch. Make sure that the Clutch Micro Switch is depressed when lever is in the face position.

The engine compartment components should be installed at this time. Carefully follow the electrical diagram provided on page 6.

THE COMPRESSOR MOUNTING COMPONENTS WILL DIFFER DEPENDING ON THE ENGINE AND DRIVE ACCESSORIES THAT YOUR VEHICLE IS EQUIPPED WITH. THE FOLLOWING INSTRUCTIONS SHOW THE PROPER INSTALLATION SEQUENCE FOR THIS VEHICLE

Locate the following components from the under hood components box.

- Condenser
- Receiver Drier / Hi –Low pressure switch
- Drier mounting bracket
- Discharge Tube
- Liquid Tubes (2)
- (2) Condenser mounting brackets top
- (2) Condenser mounting brackets bottom
- (10) #10 x 3/8 hex washer head screws
- (3) #6 o-ring
- (1) #8 o-ring

Place the condenser on the bench with fittings on the left side.

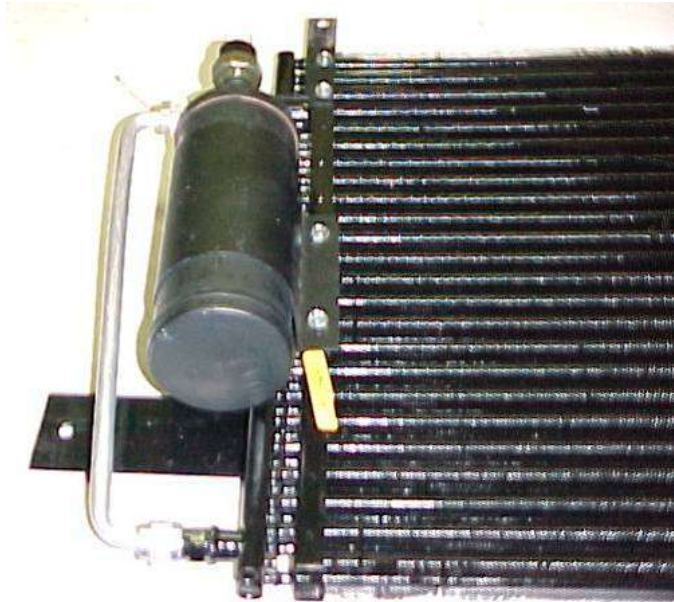

Attach drier, drier mounting bracket and liquid tube to condenser using (2) #10 screws, (2) #6 o-ring and a few drops of mineral oil on the connections.

Attach top (2) condenser mounting brackets to the condenser as shown. Use (2) #10 screws.

Attach bottom (2) condenser mounting brackets to backside of condenser on third hole from bottom of the condenser using (2) #10 screws.

NOTE: LONGEST OF THE BOTTOM BRACKETS ATTACH TO LEFT SIDE

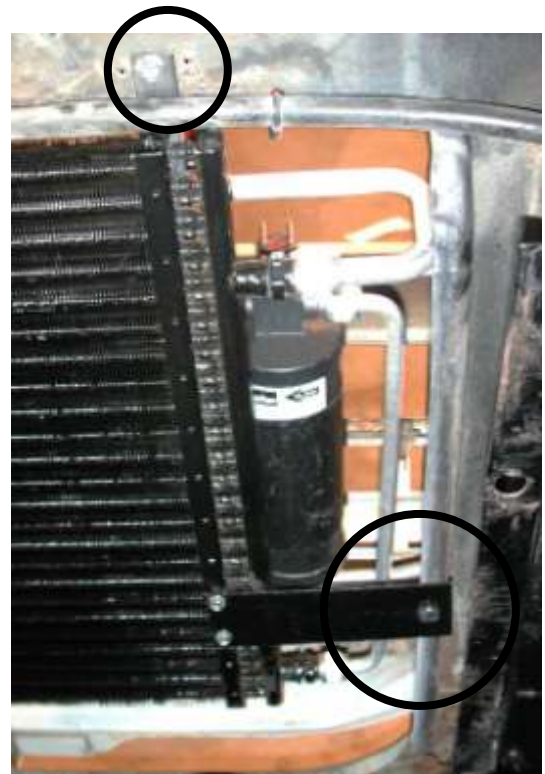
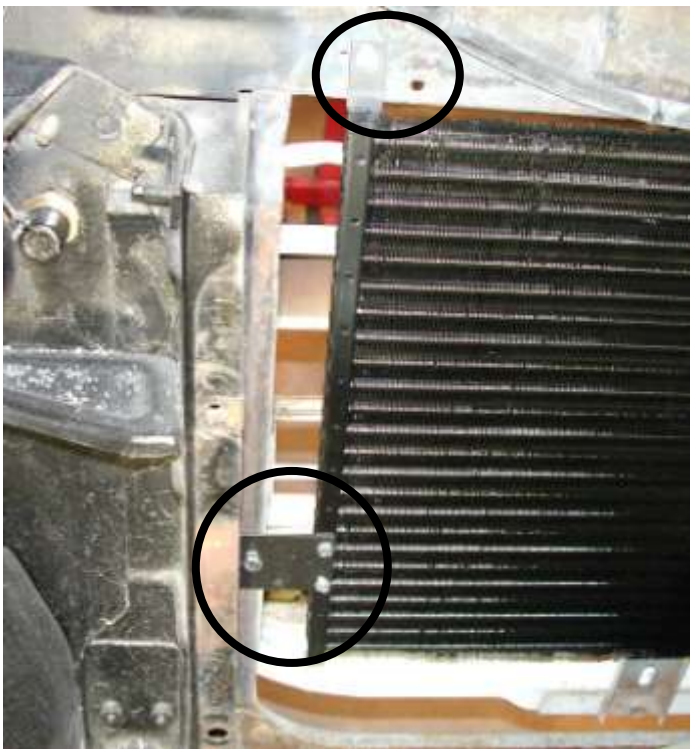

Slide condenser assembly between the Radiator and the radiator bulkhead.

Locate the condenser assembly on the radiator bulkhead. On passenger side line up condenser bracket to the flange as shown. Attach upper brackets to the bulkhead using (2) #10 tek screw.

Drill lower mounting holes through brackets and attach using (2) 1/4"-20 x 5/8" hex screw and (2) 1/4"-20 flange nuts. Tighten securely.

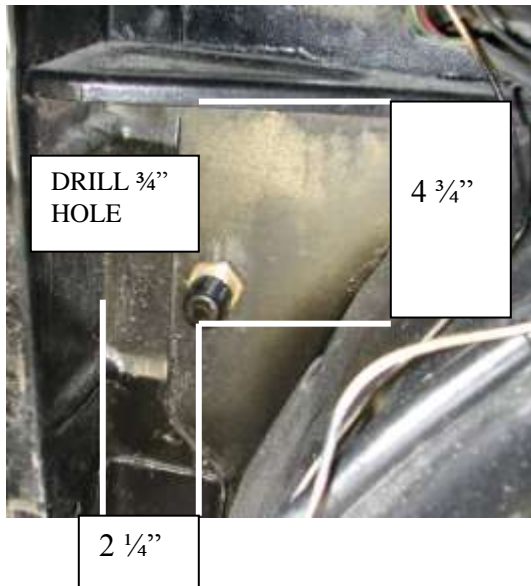

Located on the passenger side of the radiator bulkhead drill (1) hole $\frac{3}{4}$ " dia.

Locate on the drivers side of the radiator bulkhead drill (1) hole $\frac{7}{8}$ " dia.

PASSENGER SIDE OF BULKHEAD

ENGINE COMPARTMENT

DRIVERS SIDE OF BULKHEAD

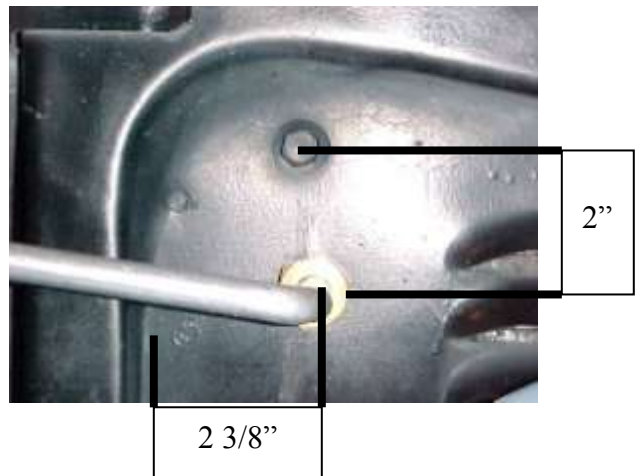

Locate in the under hood kit (1) #6 liquid tube, (1) #8 discharge tube, (1) #6 o-ring, and (2) #8 o-ring.

Attach liquid tube to the drier using (1) #6 o-ring and a few drops of mineral oil.

Route below drier and attach through $\frac{3}{4}$ " dia hole previously drilled in the passenger side bulkhead.

Attach using nut from the bulkhead fitting assembly.

Attach the #8 discharge tube to the condenser using (1) #8 o-ring and a few drops of mineral oil. Route tube across front of condenser and behind the hood latch assembly. Attach through the 7/8" hole previously drilled in drivers side bulkhead. Attach using nut from the bulkhead fitting assembly.

Locate the Hi/Low pressure switch and attach it to the drier port.

When installing the discharge tube it is necessary to remove the lower condenser mounting screws, and insert the tube from the bottom.

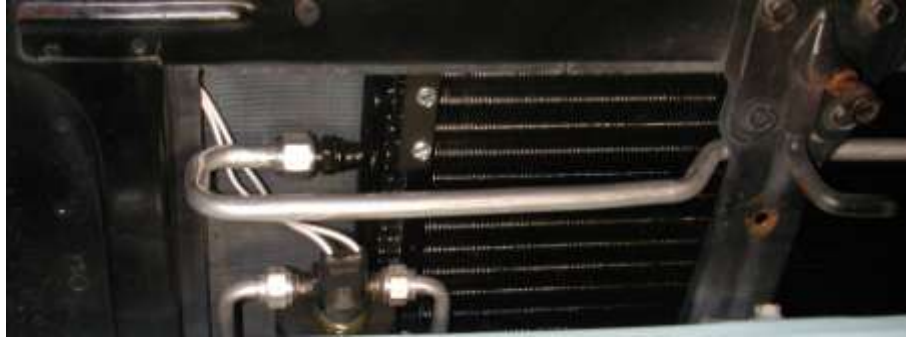

Reinstall the radiator using original hardware.



Route discharge hose from the bulkhead over to the compressor and attach end with service port to compressor using (1) #8 o-ring and a few drops of mineral oil. Tighten securely.



Locate the #10 suction hose.

Attach hose end with service port to compressor using (1) #10 o-ring and a few drops of mineral oil.

Route suction hose from compressor to #10 fitting at the firewall. Attach to fitting using (1) #10 o-ring and few drops of mineral oil.



Tighten all fittings securely.

Hookup heater hoses to the connections coming through the firewall.

NOTE: THE SUPPLY LINE FROM THE ENGINE WILL BE HOOKED TO THE LEFT FITTING USING A WORM GEAR CLAMP.

It is recommended that the heater hoses be replaced at this time.

Locate in the Hardware Sack Kit the Water Valve and (3) worm gear clamps. Cut 6" off of the return heater hose and attach to the connector then to the water valve and then to the remaining hose that goes back to the engine. Use the worm gear clamps supplied.

Locate the Temperature Control Cable and attach it to the water valve as shown. Set the cable so that the Temp knob is pushed all the way in and the water valve is in its fully closed position.

Locate electrical plug that attaches to the Pressure switch on the drier

There are two white wires attached to the pressure switch route one of them to the compressor clutch and attach a Female bullet connector. The other wire route along the Liquid hose and attach to clutch wire at the firewall. Secure wires with tywraps provided.

Use the same refrigeration tape, seal around the cable and clutch wire.

Reinstall battery, hookup radiator hoses and refill with coolant.

***THE ENGINE COMPARTMENT OF YOUR SYSTEM IS COMPLETE.
THE UNIT IS READY FOR EVACUATION AND CHARGING.***

***THIS SHOULD BE DONE BY A QUALIFIED AND CERTIFIED AIR
CONDITIONING TECHNICIAN.***

***NOTE: COMPRESSOR IS SUPPLIED WITH THE
CORRECT OIL CHARGE. DO NOT ADD OIL TO SYSTEM.***

***134a SYSTEMS 24 oz OF REFRIGERANT
Recommend that power fuse is 25amp minimum***

***Congratulations you have completed the install of your
CLASSIC AUTO AIR "Perfect Fit Series" system.***

IMPORTANT

CAUTION: WATER VALVE MUST BE INSTALLED PER THE INSTRUCTIONS.

Classic Auto Air has done extensive testing on the correct method to install the water valve in order to get a repeatable and progressive temperature control.

Locate the **bottom** connection from the evaporator/heater unit off of the firewall and attach a 6" piece of 5/8" dia. heater hose with the supplied hose clamp. Next attach the inlet side of the water valve using another supplied hose clamp, (make sure the arrow on the water valve points toward the engine) Attach a heater hose from the outlet side of the water valve and route to the connection on the water pump.

NOTE: WATER VALVE = WATER PUMP

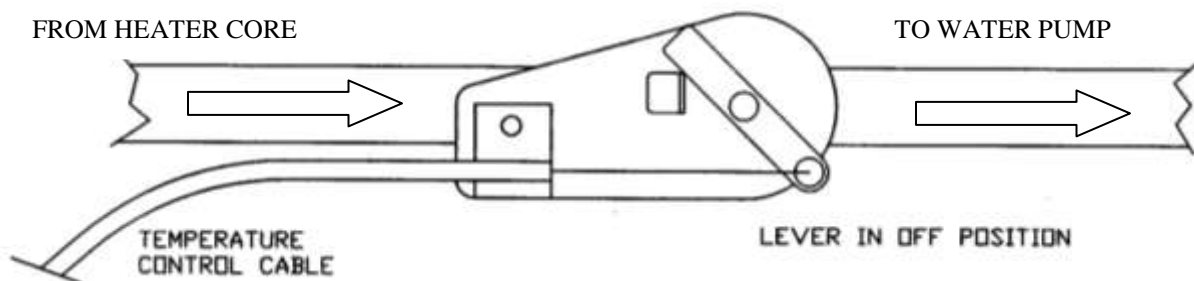

CAUTION: WATER VALVE MUST BE INSTALLED ON HEATER LINE ROUTED TO WATER PUMP.

NOTE: COMPRESSOR PURCHASED WITH KIT IS SUPPLIED WITH THE CORRECT OIL CHARGE. DO NOT ADD OIL TO SYSTEM.

134A SYSTEMS 24 oz OF REFRIGERANT

Recommend that power fuse is 25amp minimum