

Installation Manual

1967-1968 Mustang Factory Air

DOCUMENT #1-2026FA

©2012 ClassicAutoAir / vs2.12



Congratulations...

You have just purchased the highest quality, best performing A/C system ever designed for your Classic Vehicle.

To obtain the high level of performance and dependability our systems are known for, please pay close attention to the following instructions. Our installation steps and procedures are derived from a long history of research and development and the combined experience achieved thru thousands of successful installations (and feedback from customers like you). Please remember that our #1 goal is that you'll have a successful installation and a system that performs at a very high level for many years to come.

Before starting, read the instructions carefully, from beginning to end, and follow the proper sequence. On the next page you'll find a safety and general checklist that you should read before starting your installation.

Again, thank you from our entire staff.

Check List, Pre-Installation:

- Before beginning the installation check the shipping box for the correct components. YOUR BOXED UNIT INCLUDES A LIST OF MAJOR COMPONENTS AND A LIST OF BAGGED PARTS. We have a 5 stage check process to make sure you have everything you'll need.
- If your vehicle has been or is being modified, some procedures will need to be adjusted to fit your particular application.**
- A basic cleaning of the engine compartment and interior before beginning will make things go more smoothly.
- Check condition of engine mounts. Excessive engine movement can damage hoses to A/C and/or heater.
- Before starting, check vehicle interior electrical functions (interior lights, radio, horn, etc). Make a note of anything that does not work as it's supposed to. During the installation you might find the opportunity to repair or upgrade non-working or out of date components. When you're ready to start the installation, **DISCONNECT THE BATTERY FIRST.**
- Drain the radiator. Retain the coolant and reuse, or dispose of properly.
- SAFETY FIRST: Wear eye protection while drilling/cutting, deburr sharp edges, and never get in a hurry or force a part.
- Tools: Your installation only requires the basic tools everyone has in their garage, nothing exotic or specific to A/C or Heat equipment.

Procedures, During Installation:

- Fittings: Use one or two drops of mineral oil (supplied with your kit) on ALL rubber o-rings, threads and rear of bump for o-ring where female nut rides. Do not use thread tape or sealants.
- Measure twice (or more), cut once
- Should you have any technical questions, or feel you have defective components (or missing items), call us immediately, we will be glad to assist you. Our toll-free number is listed on every page, we're here to help!**

YOU CAN NOW BEGIN THE INSTALLATION...

A Basic Overview of Automotive A/C....

- 1 Evaporator with Blower Fan** In order to remove the heat from the air in the vehicle, the A/C evaporator allows the refrigerant to absorb the heat from the air passing over it. The blower fan moves cool air out into the car interior.
- 2 Compressor** The compressor pumps and circulates the refrigerant through the system.
- 3 Condenser** The condenser is a heat exchanger mounted at the front of the vehicle. Heat drawn out of the interior of the car is expelled here.
- 4 Receiver/Drier** The drier not only dries refrigerant, it also filters the refrigerant and stores it under certain operating conditions.
- 5 High Pressure Switch** A pressure switch is used to shut down the system if high or low pressure is detected, basically it acts as a safety switch.

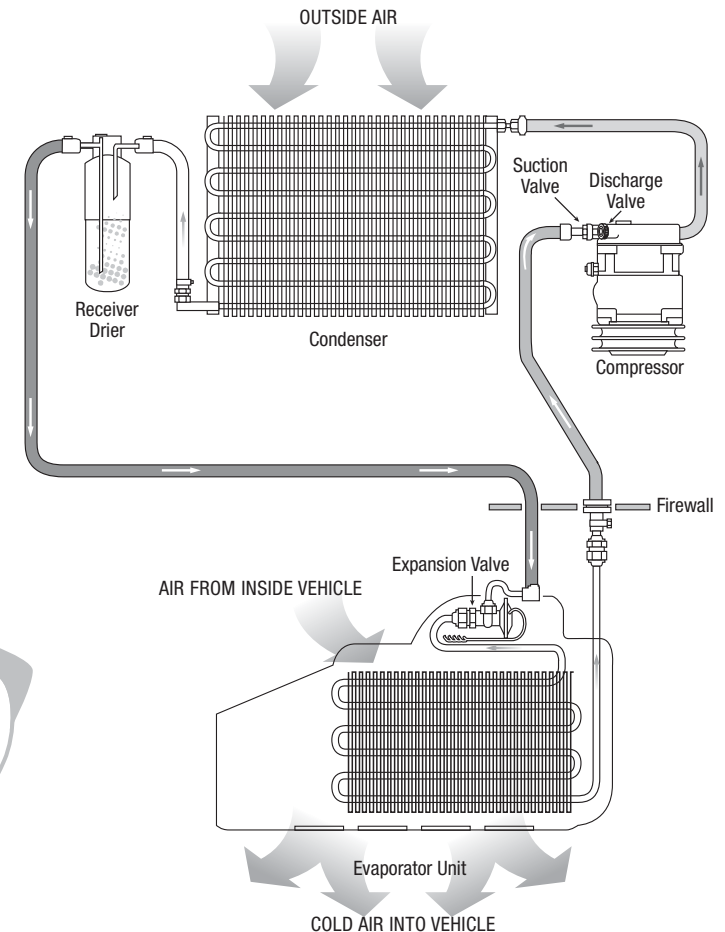
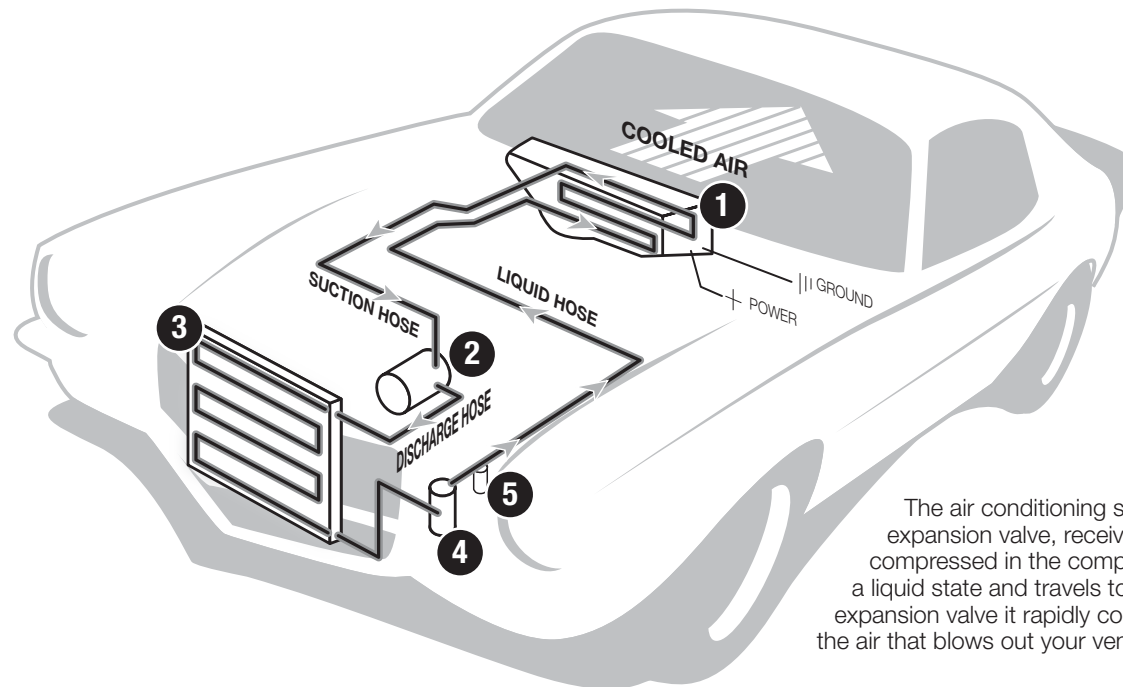

The air conditioning system in your car is comprised of a compressor, condenser, expansion valve, receiver/drier, and evaporator. Refrigerant (also known as Freon) is compressed in the compressor and turns into a gas. In the condenser, this gas is cooled to a liquid state and travels to the expansion valve. As the liquid refrigerant goes through the expansion valve it rapidly cools in the evaporator. A fan blows over the evaporator and cools the air that blows out your vents. The receiver-drier separates gas and liquid.



Remove Glovebox, Console (if equipped) Radio and Bezel, and set them aside for reinstall later (see figure 1).

The removal of the OEM evaporator can be accomplished by disconnecting the two control cables. One is attached to the Heat/Defrost door (see figure 2). One is attached to the Temperature door, and one is attached to the Vent/Heat door (see figure 3). Disconnect the electrical harness from the assembly. Also remove attachment screw located in front of the air inlet (see figure 4).

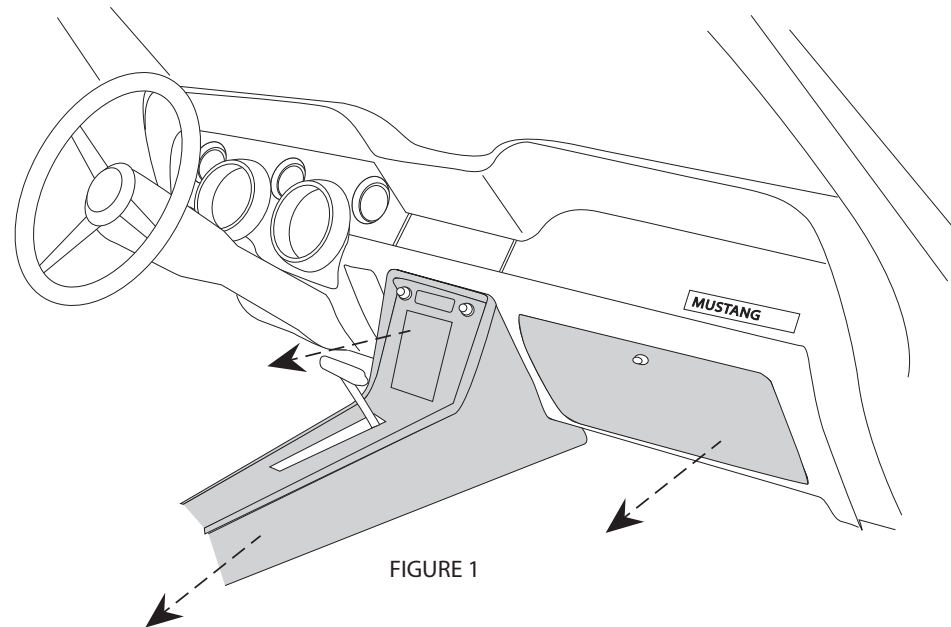

FIGURE 1



When retaining parts it's a good idea to store parts in a zip lock bag, labeled with info where the parts came from and what size/type of tool is needed to reinstall. Cleaning the parts before you need to reinstall them is a good idea too.

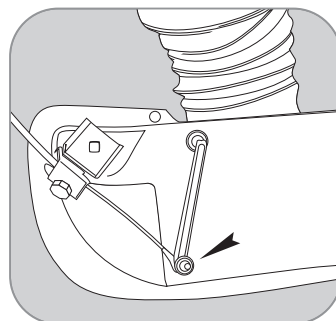

FIGURE 2

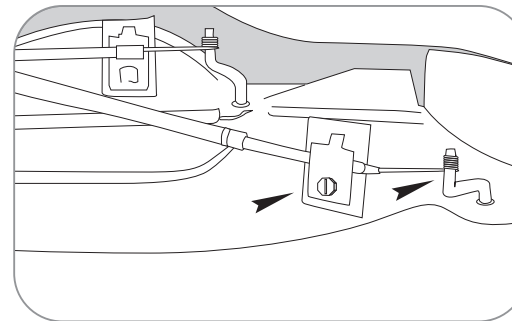

FIGURE 3

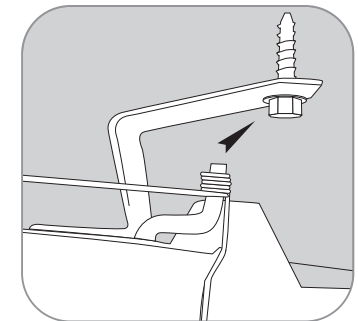

FIGURE 4

Locate blower motor on the firewall (Passenger Side) in the engine compartment. Remove all 4 nuts around blower. Also disconnect the electrical connector from the blower motor (see figure 5A). Cut wires at grommet in firewall.

DRAIN COOLANT FROM RADIATOR and store safely to reuse or recycle accordingly. Cut heater hose approximately 1" from firewall (see figure 5B). Also, to prevent forgetting to refill the coolant when the installation is completed, do not put the cap back into place - instead put the cap to the side and cover radiator hole with a clean rag or something similar.

Located on the drivers side lower dash is a fresh air vent assembly. Remove this unit and set aside (it will not be reinstalled, see figure 6, and NOTE below).

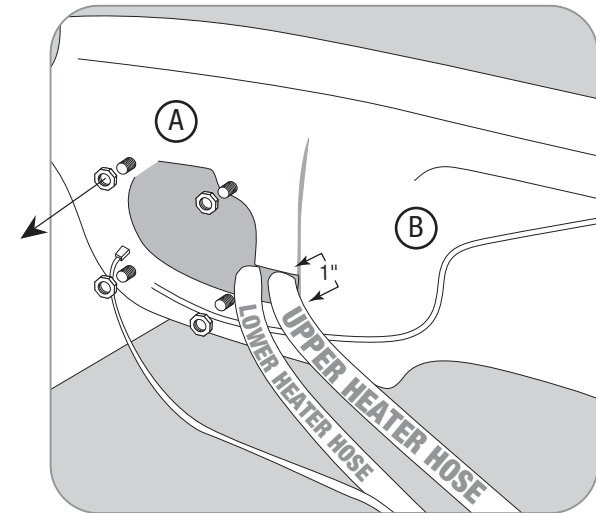

FIGURE 5

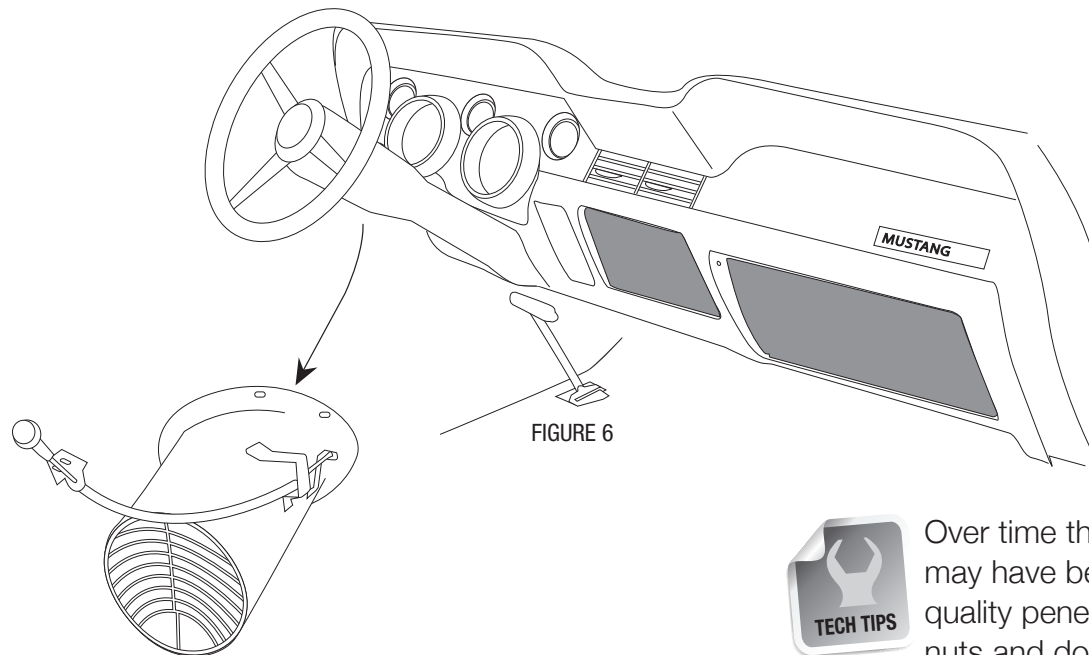
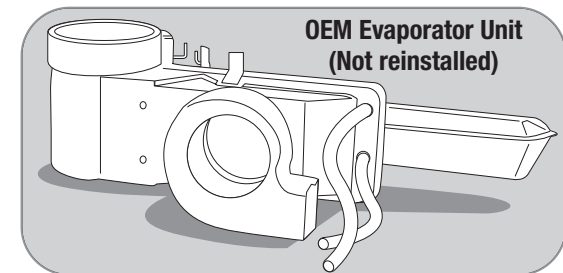

FIGURE 6



Over time the nuts that hold the OEM fresh air vent assembly may have become rusty or fused to the studs. Use a good quality penetrating spray to help the process of removing the nuts and don't over-stress the studs.

THESE ARE THE PARTS YOU WILL FIND IN BAG KIT A

You will use all of these parts and hardware during the next series of installation steps.

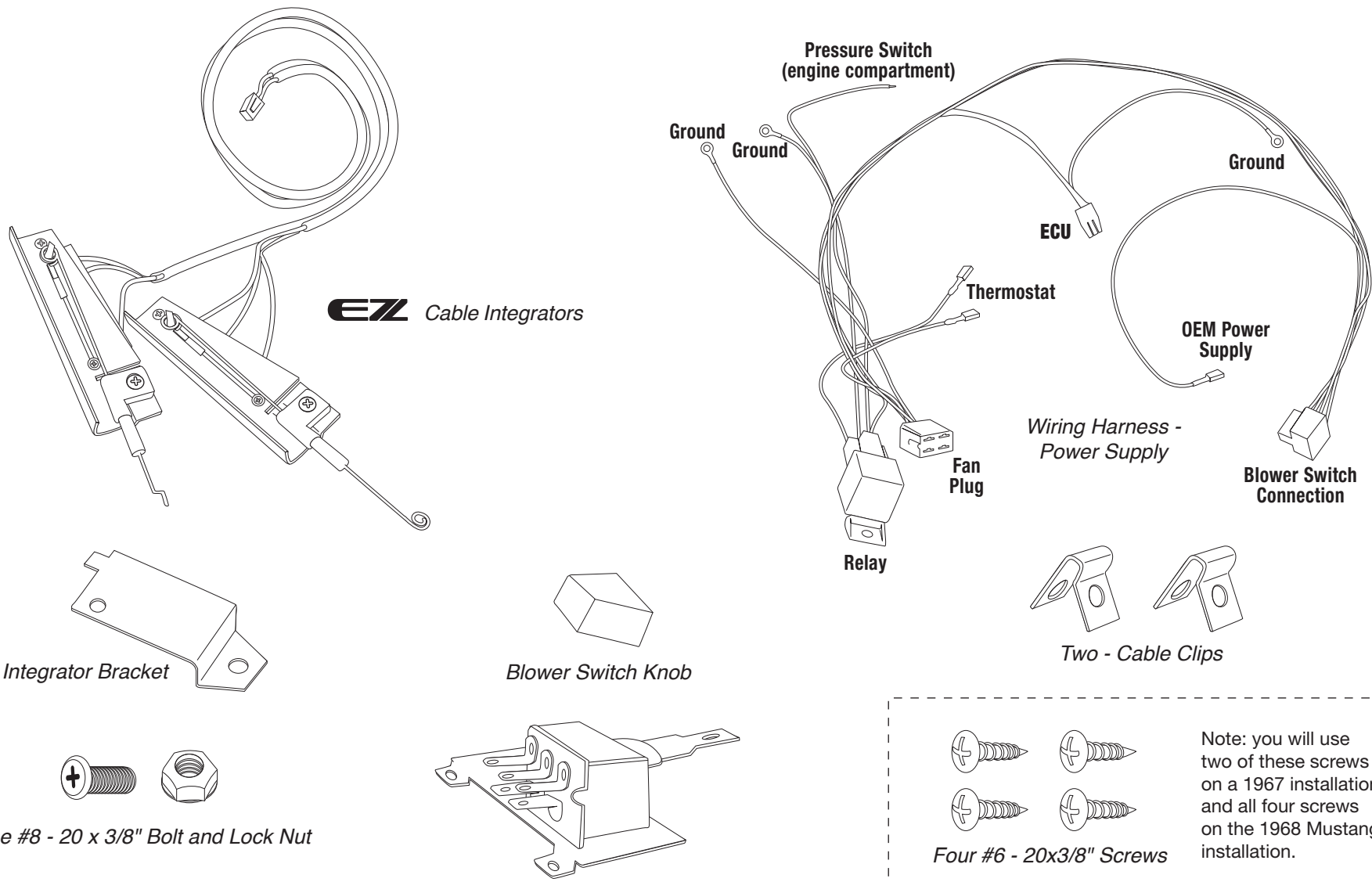

EZ Cable Integrators

Integrator Bracket

Blower Switch Knob

Two - Cable Clips

One #8 - 20 x 3/8" Bolt and Lock Nut

Blower Switch and Bracket

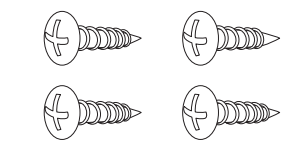

Four #6 - 20x3/8" Screws

Note: you will use two of these screws on a 1967 installation and all four screws on the 1968 Mustang installation.

NOTE: Illustrations NOT shown actual size

Remove The A/C Control Head From The Dash.

- 1) There are four OEM screws that hold your control head to the dash, two on the lower side and two on the upper. Remove and retain these screws. Remove the control head assembly.
- 2) Remove the OEM blower switch knob. Retain the screw, you will use it again shortly. Remove the control cables and the original blower switch and set aside (these will not be reused).
- 3) Cut off and discard the small retaining clip on the lever arm (see inset, figure 7, 1968 control head only).

1967 CONTROL HEAD: Attach the new blower switch with bracket to the top part of the back of the face plate (see figure 7), utilizing the two OEM screws.

1968 CONTROL HEAD: Remove the rotary vacuum switch and set aside (retaining the OEM screws). Utilizing the supplied template (see figure 8) you will need to drill two holes for mounting the blower switch bracket. Slip the template in behind the lever and align the circles marked "OEM" to the original holes on the control body that previously held the vacuum switch. Secure the template to the control body (with tape) and drill thru the holes marked "drill" with a 9/64" drill bit. Attach the blower switch and bracket with the two supplied #6 - 20x3/8" screws. .

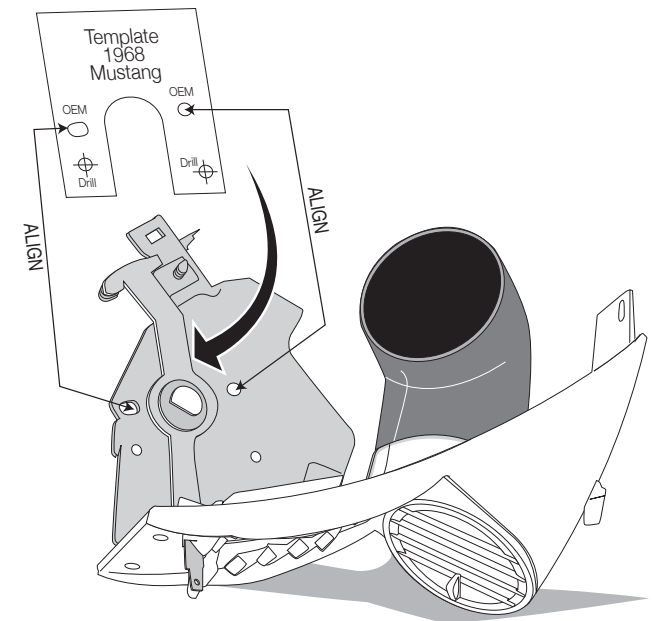

FIGURE 8

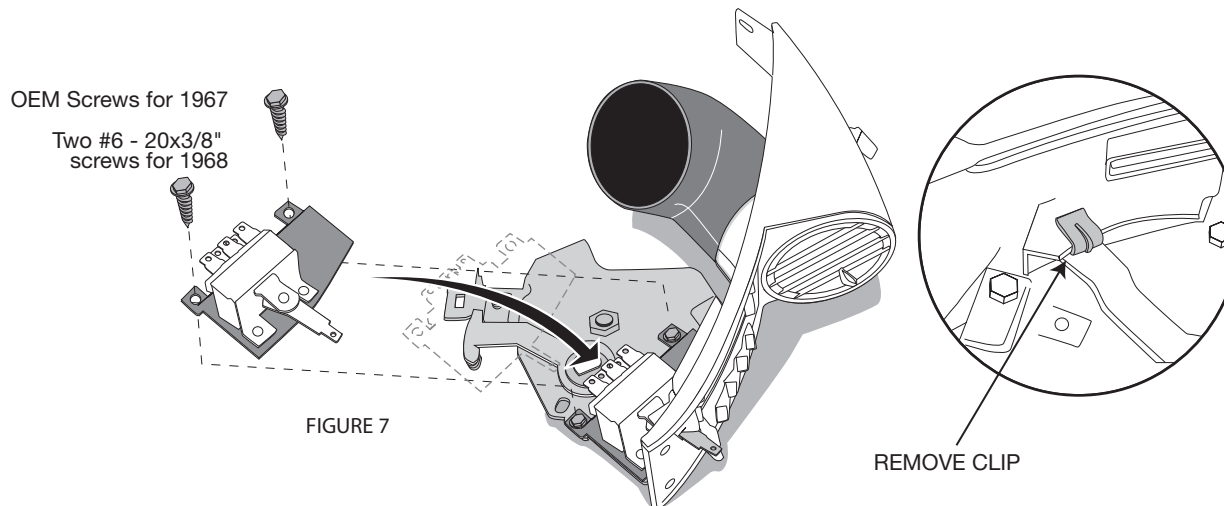
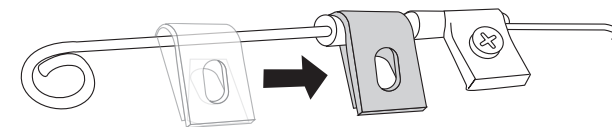
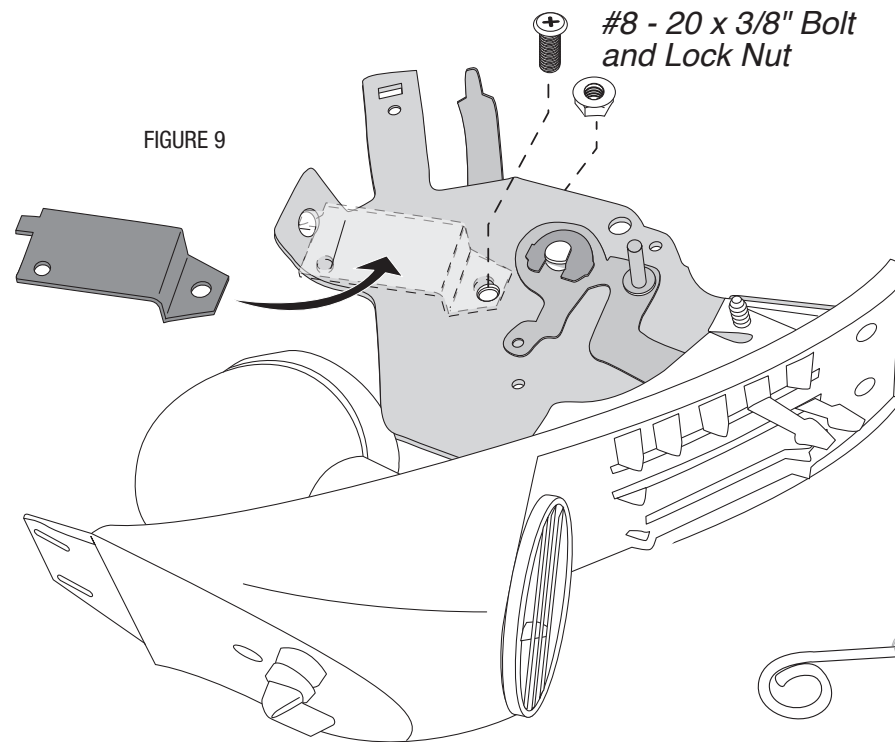
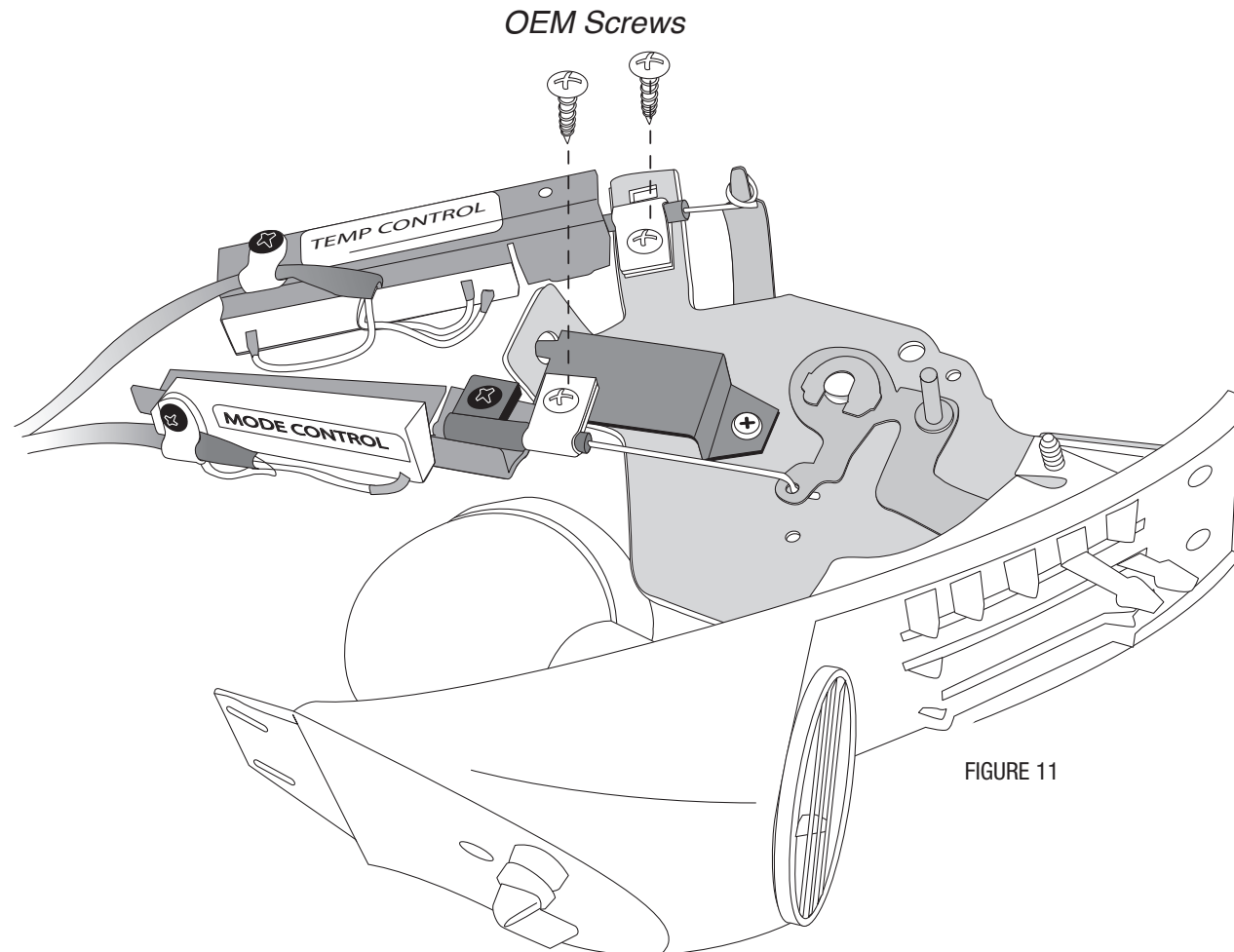

FIGURE 7

Attaching our exclusive **EZ** cables to the control head is accomplished in three easy steps: **Step 1)** First attach the integrator bracket to the control head body (see figure 9) by placing the bracket into position and placing the “ear” thru the hole in the OEM cable guide hole and securing with one #8 - 20 x 3/8” bolt and locknut (see figure 9).



Step 2) Slide the supplied cable clamps over the end of both of the cables (see figure 10) and then route the wire ends of the new cables over the appropriate lever ends (one is a “dog-leg” end and the other is a “loop”, as shown in figure 11). Secure the cables to the mounting points (one to the new bracket and one to the control head) using the #8 - 20x3/8" screws.



Plug the harness blower switch connection into the back of the control head and insert the entire harness and switch component back into the dash. Position the entire control head back flush with the lower dash and secure with the OEM retainers and nuts you removed earlier (see figure 13).

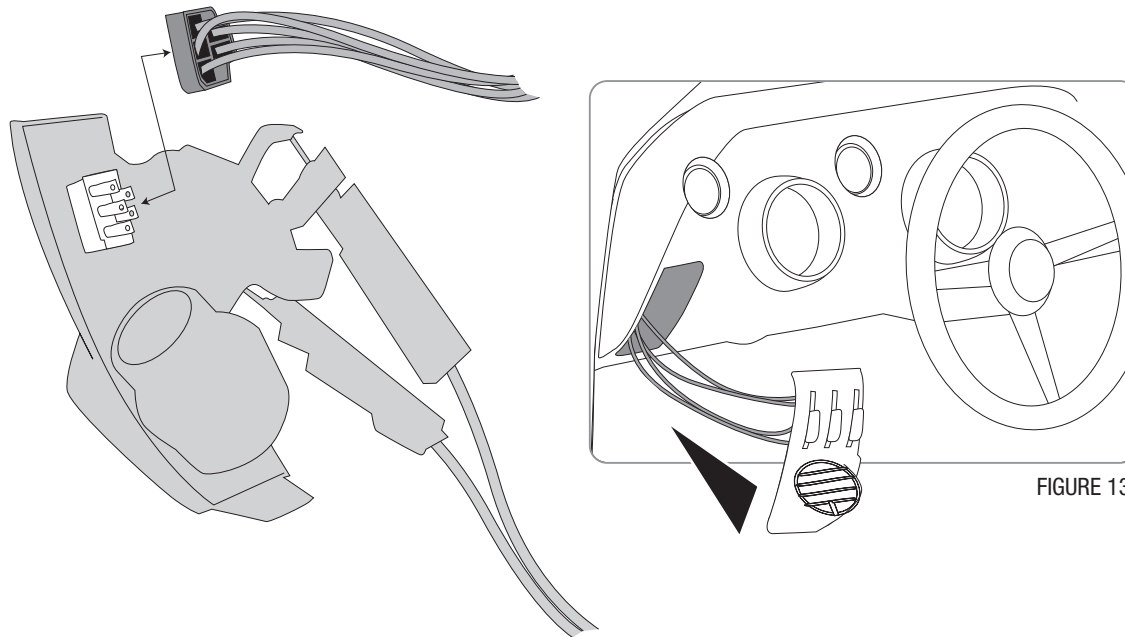

FIGURE 13

THESE ARE THE PARTS YOU WILL FIND IN BAG KIT B

You will use all of these parts and hardware during the next series of installation steps.



Evaporator Support Bracket

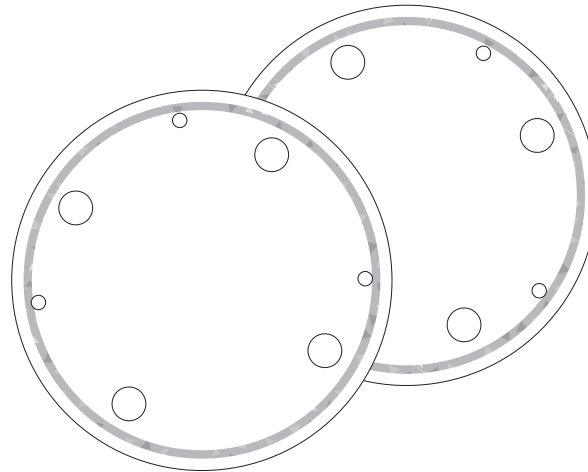

Two Fresh Air Inlet Block Offs

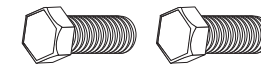

Two 1/4 - #20 x 5/8" Bolts

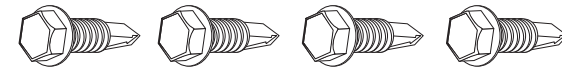

Four #10 - 16 x 3/4" Tek Screws

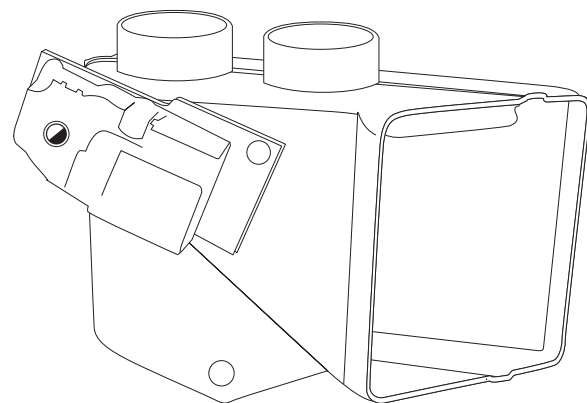

Defrost/Heat Duct Assembly



One Male Spade Connector



Four #10 - 10 x 5/8" Phillips Screws



One J-Clip



One 1/2" Washer

Illustrations NOT shown actual size

Locate the original wiring harness that supplied power to the original heater motor (these wires were previously cut on the engine side of the firewall). Reaching thru the glove box opening pull these wires out of their grommet. Measure 4" off of the main harness and cut both wires (see figure 14). On the OEM power supply wire attach a 1/4" insulated male spade connector. Within the OEM fuse box upgrade the factory HEATER fuse with a 20 amp fuse (**VERY IMPORTANT**).

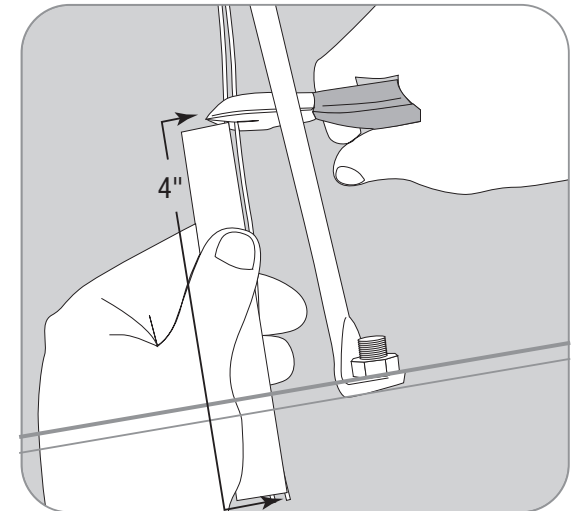

FIGURE 14

Locate the bottom left mounting hole in the firewall that attached the original heater motor. From inside of the vehicle drill a 5/8" dia. hole for the drain tube. **TEMPLATE NOTIFICATION!** A handy drilling template is included in this manual (example shown in figure 15).

CAUTION: On the engine side of the firewall there is a brake line. Be careful not drill through the brake line. It may be necessary to carefully push this line out of the way, securing it a bit lower is usually all that is necessary (see figure 16).

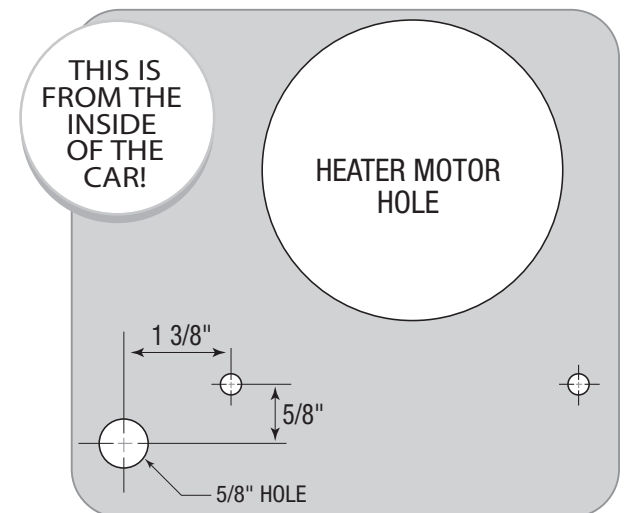

FIGURE 15

All preliminary modifications to the vehicle are complete.



YOU CAN DRILL A SMALL PILOT HOLE IN THIS LOCATION FIRST WITH A SMALLER DRILL BIT (LIKE A 9/32"), THEN PROCEED WITH THE 5/8" BIT ONCE YOU KNOW YOU HAVE CLEAR SPACE.

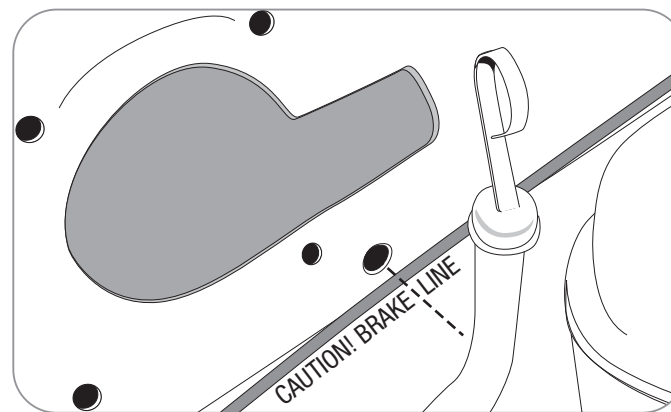

FIGURE 16

You can now begin installing your Classic Air Perfect Fit Elite System.

Locate the Fresh Air inlet block off. Install over hole in inlet cowl as shown on the passenger side (see figure 17A). Attach with three #10 - 16 x 3/4" Tek Screws. Locate the mounting tab location as shown and attach the 1/4" 20 J-clip supplied (see figure 17B).

Install a Fresh Air inlet block off over the vent opening at the drivers-side in the same way, using the four OEM nuts.

Remove evaporator unit from box and place on a flat work surface.

Locate defrost / heat duct assembly and attach to the evaporator using two #10 - 10 x 5/8" Phillips screws (see figure 18). NOTE: Be sure that the s-clips are pushed over rear flange on evaporator.

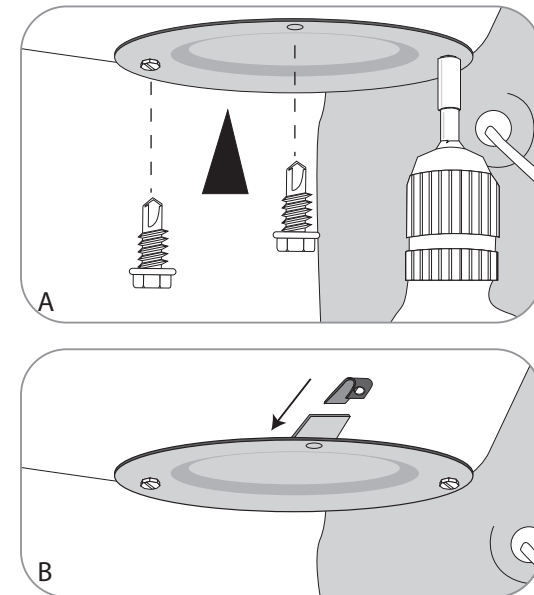

FIGURE 17

Take a minute to familiarize yourself with the evaporator unit:

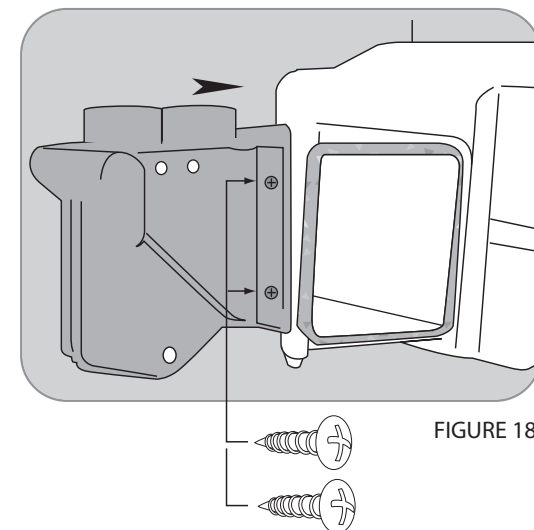
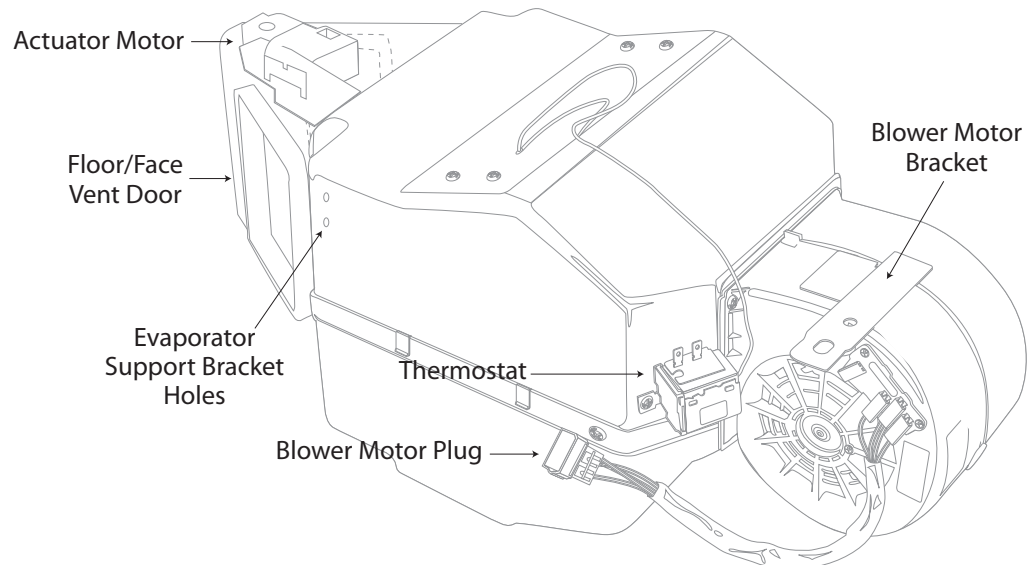

FIGURE 18

Installing the complete evaporator unit under the dash will go much easier with the help of a friend. One person can take the unit within the car and “roll” up and under the dash while the other person can be ready at the firewall area with one of the 1/4" - #20 x 5/8" bolts to secure the unit in place (see figure 19). Now the unit will be easy to level and secure. Leveling the unit is very important to insure proper drainage of condensation.

On back side of the evaporator is a mounting bracket with a 1/4"-20 J-clip. This bracket will go flush with the inside firewall and you will secure the evaporator by inserting one 1/4" - #20 x 5/8" bolt with a 1/4" washer (from the engine side) using the bottom right hole (that originally attached the original heater assembly, see figure 20).

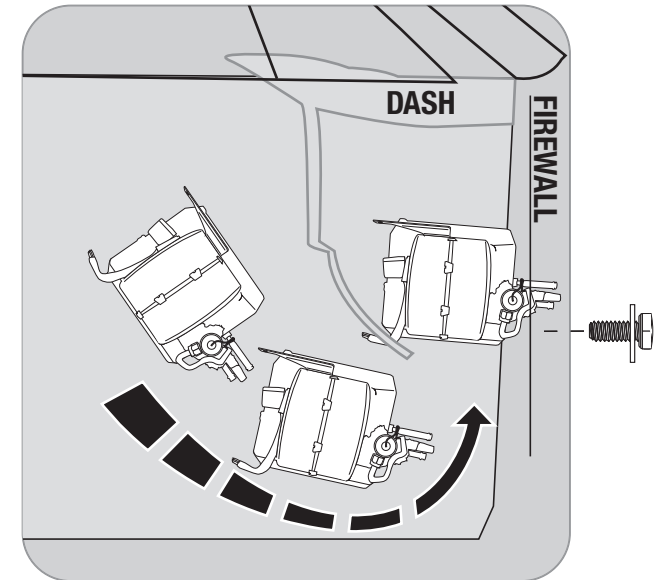
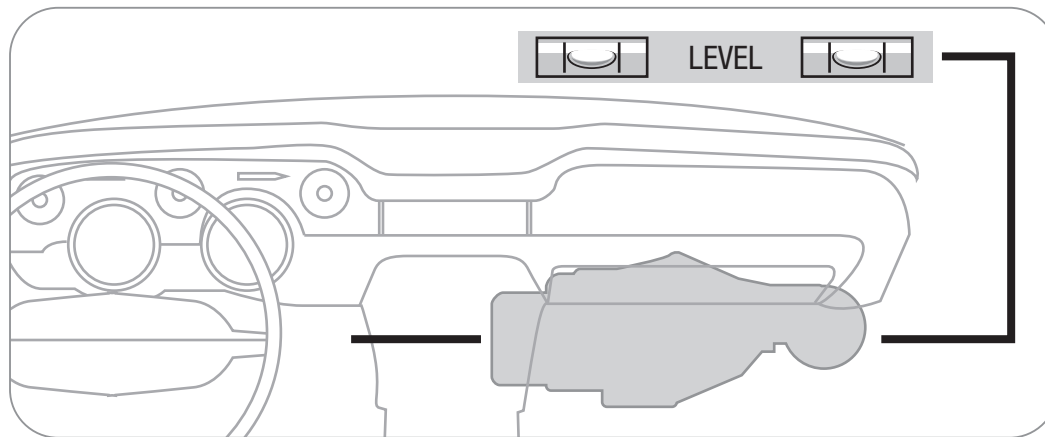

FIGURE 19



Be sure to align the evaporator unit level with the bottom of instrument panel (assuming the vehicle is sitting level) as shown above, but with a small degree of tilt toward the back to allow proper drain of condensation.

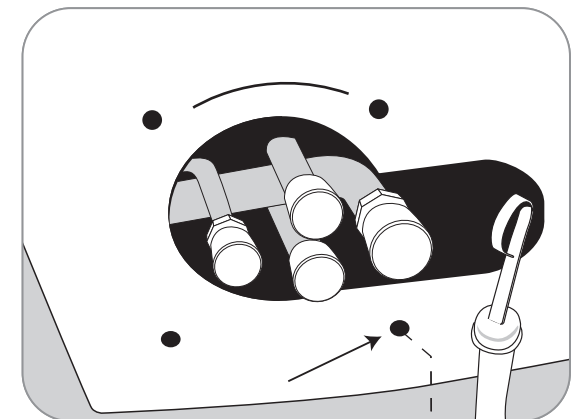
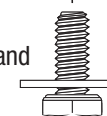

FIGURE 20

1/4" - #20 x 5/8" bolts and
a 1/4" washer



The second 1/4 - #20 x 5/8" bolt attaches the blower motor mounting bracket in the same location as the original heater mounting in front of the Air Inlet. The blower support bracket will have an additional hole behind the 1/4 - #20 x 5/8" Bolts. Install a #10 - 16 x 3/4" Tek screw through this hole and into the cowling (see figure 21).

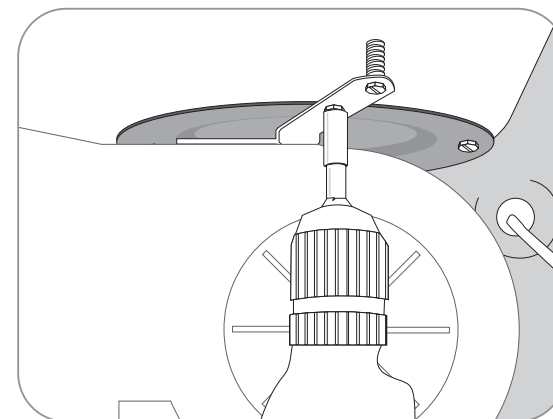

FIGURE 21

Locate in bag kit B the UPPER MOUNTING BRACKET and attach to evaporator unit using two #10 - 10 x 5/8" Phillips screws. Attach other end to the cowling with a #10 - 16 x 3/4" Tek Screw (see figure 22). **IMPORTANT NOTE: On the side of the main unit you will see several holes for mounting holes... ONLY USE THE ONES ON THE FAR LEFT FOR THIS BRACKET!** Do not tap into the other holes for any reason (see figure 23). Also, use a screwdriver and hand-power and do not over-tighten so you don't strip the holes.

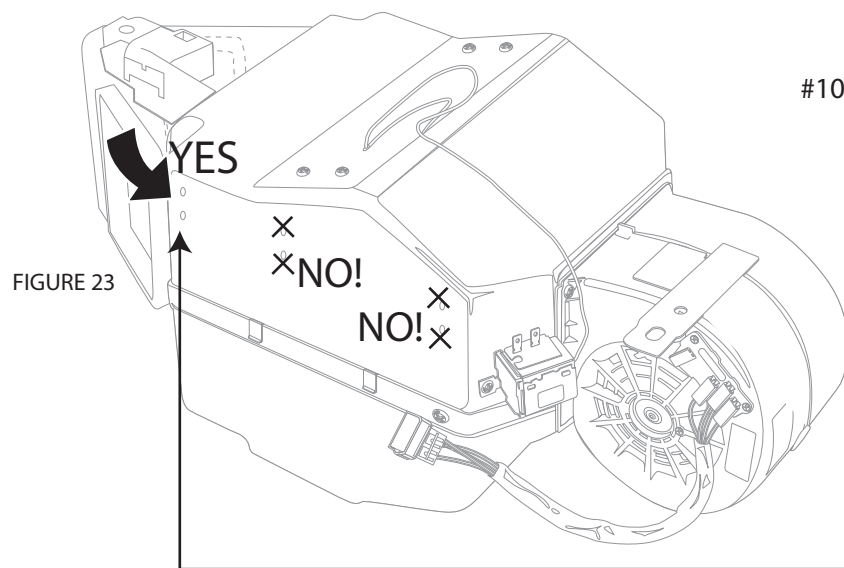

FIGURE 23

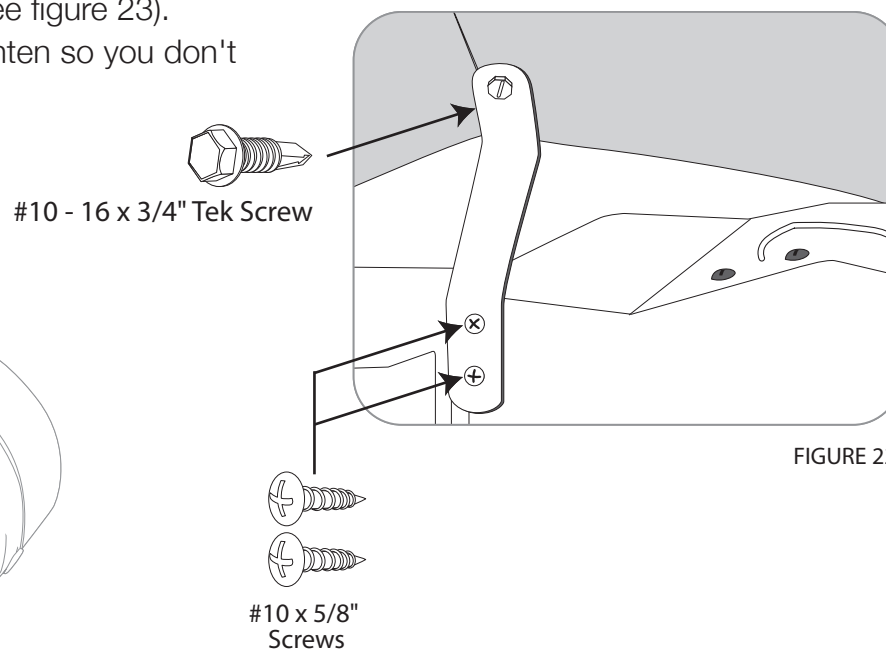
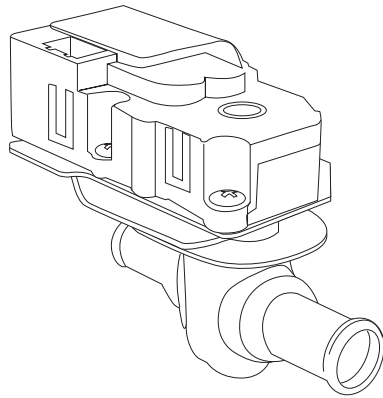

FIGURE 22

THESE ARE THE PARTS YOU WILL FIND IN BAG KIT C

You will use all of these parts and hardware during the next series of installation steps.



Electronic Water Control Valve

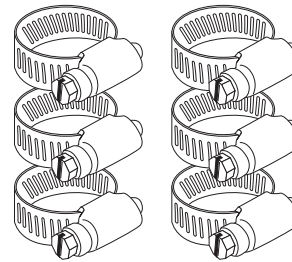

Six Worm Gear Clamps

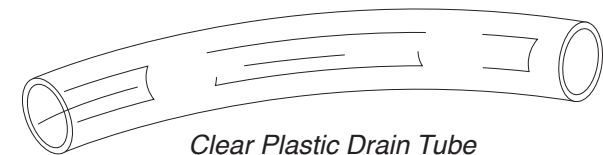

Clear Plastic Drain Tube

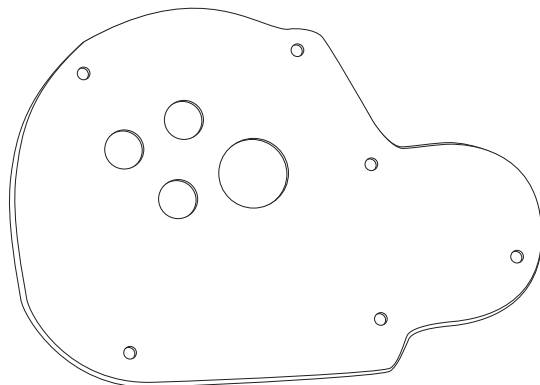

Firewall Block Off

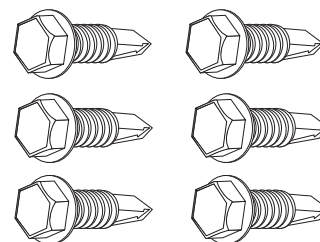

Six #10 - 16 x 3/4" Tek Screws

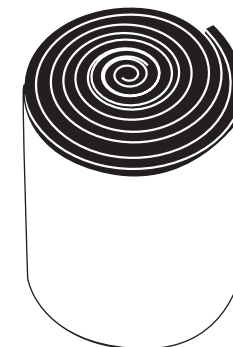

Refrigerant Tape

Illustrations NOT shown actual size

Water valve hose connects to this connection

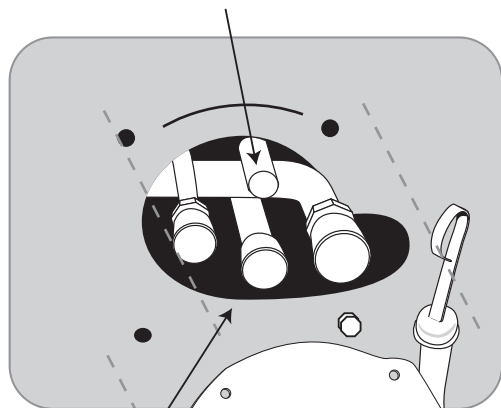

FIGURE 23

This inlet is connected to the intake manifold

In **Bag Kit C** you'll find the firewall block off. Install this over the hose connections coming thru the firewall within the engine compartment. Attach with six #10 - 16 x 3/4" Tek screws (Figure 23). Seal around the tubes with the included refrigerant tape. This will keep unwanted moisture and debris from entering thru the firewall... so seal carefully and thoroughly.

IMPORTANT NOTICE Classic Auto Air has done extensive testing on the correct method to install the water valve in order to get a repeatable and progressive temperature control. **The water valve must be installed per these instructions!....**

The **lower** connection on the tubes coming thru the block off assembly is going to be routed to the water outlet on the intake manifold. Attach your hose with cable clamps on both ends and route where it will not interfere with linkage or come in contact with exhaust manifolds or headers.

The **upper** port coming thru the firewall will be routed to and thru your new your electronic water valve (the water valve is marked for easy installation). First Attach a 6" piece of 5/8" dia. heater hose with the supplied worm gear clamp. Attach to the inlet side of the water valve using another supplied hose clamp.

Attach a heater hose from the outlet side of the electronic water valve and route to the connection on the water pump.

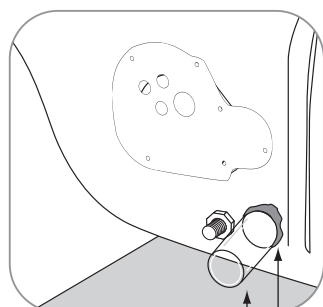
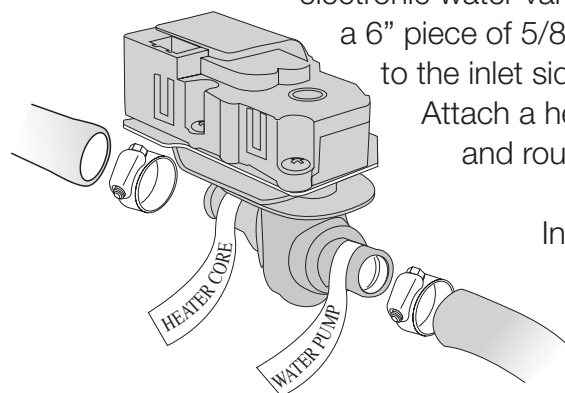

FIGURE 24

1/2" Clear Drain Tube
Refrigerant Tape



Insert a 6" piece of the clear, 1/2" drain tube we included through the hole previously drilled and attach over the drain nipple (see figure 24). Seal around tube with refrigerant tape.

THESE ARE THE PARTS YOU WILL FIND IN BAG KIT D

You will use all of these parts and hardware during the next series of installation steps.

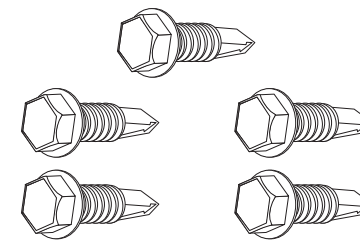
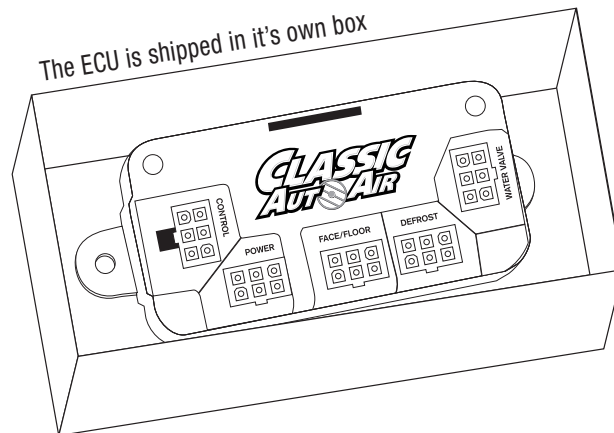

Five #10 - 16 x 3/4" Tek Screws

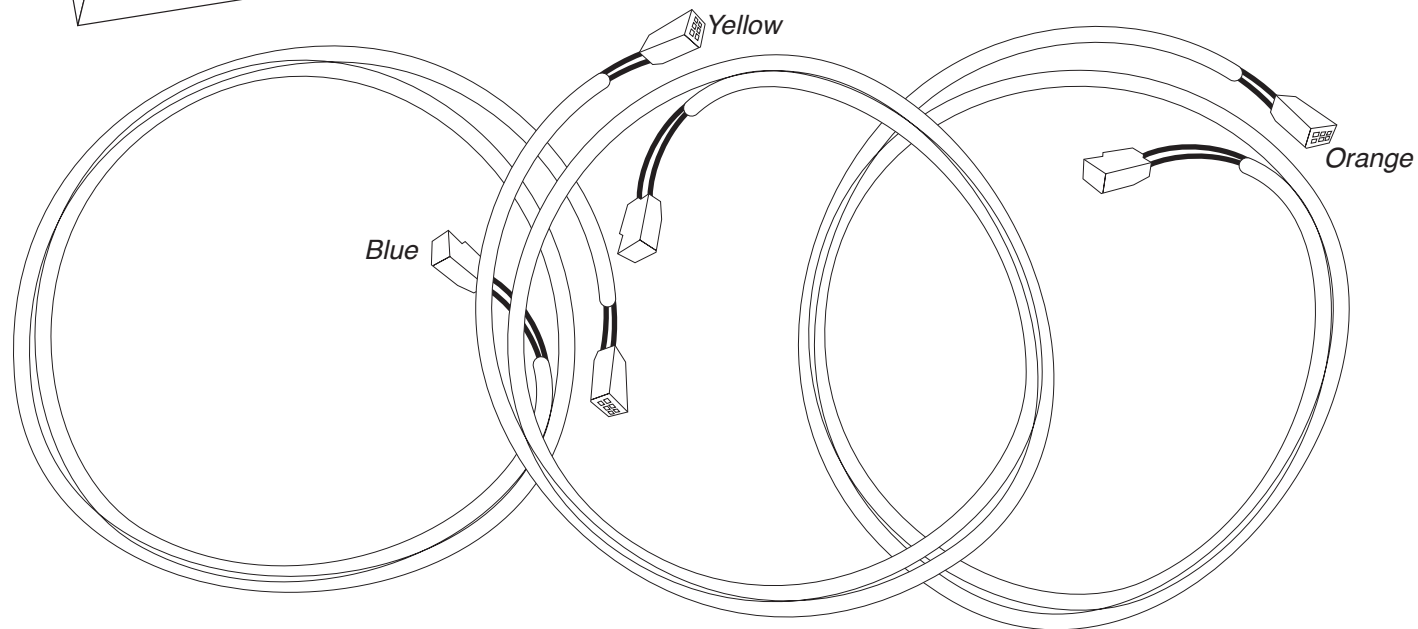

EZ Wire Harness System

Illustrations NOT shown actual size

We've included enough wire length to allow you to mount the ECU in a variety of places. It is very important that you mount this in a place where it will stay dry and that vibration is at a minimum. Also make sure that where ever you mount it does not interfere with any moving controls or cables. We recommend mounting it just above the right hand side of the main unit using the included tek-screws. **IMPORTANT! DON'T MOUNT THE ECU PERMANENTLY JUST YET. THAT CAN BE DONE AFTER YOU CALIBRATE THE UNIT (SEE PAGE 19).**

In **Bag Kit D** you will find three wiring harnesses with connections at each end. Plug the harness with **YELLOW** band into the **YELLOW ECU** port and the other end into the servo motor on the main unit (motor is marked with **YELLOW INDICATOR**). Repeat this process for the other two harnesses, following the color coding indicated on cables and ports. Attach cable in the engine compartment to the electronic water valve (see figure 25).

NOTE: The **GREEN** harness connection will be made from the harness you previously installed, just plug the loose connection in the CONTROL port on the ECU.

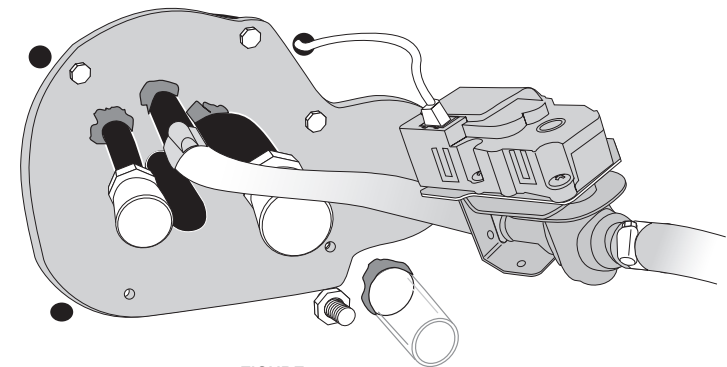
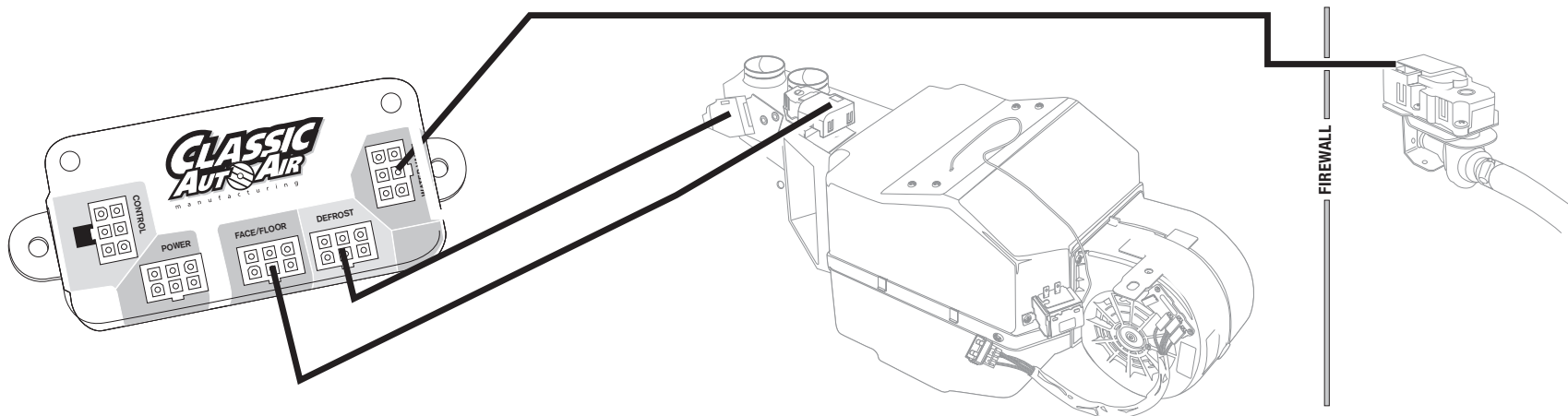
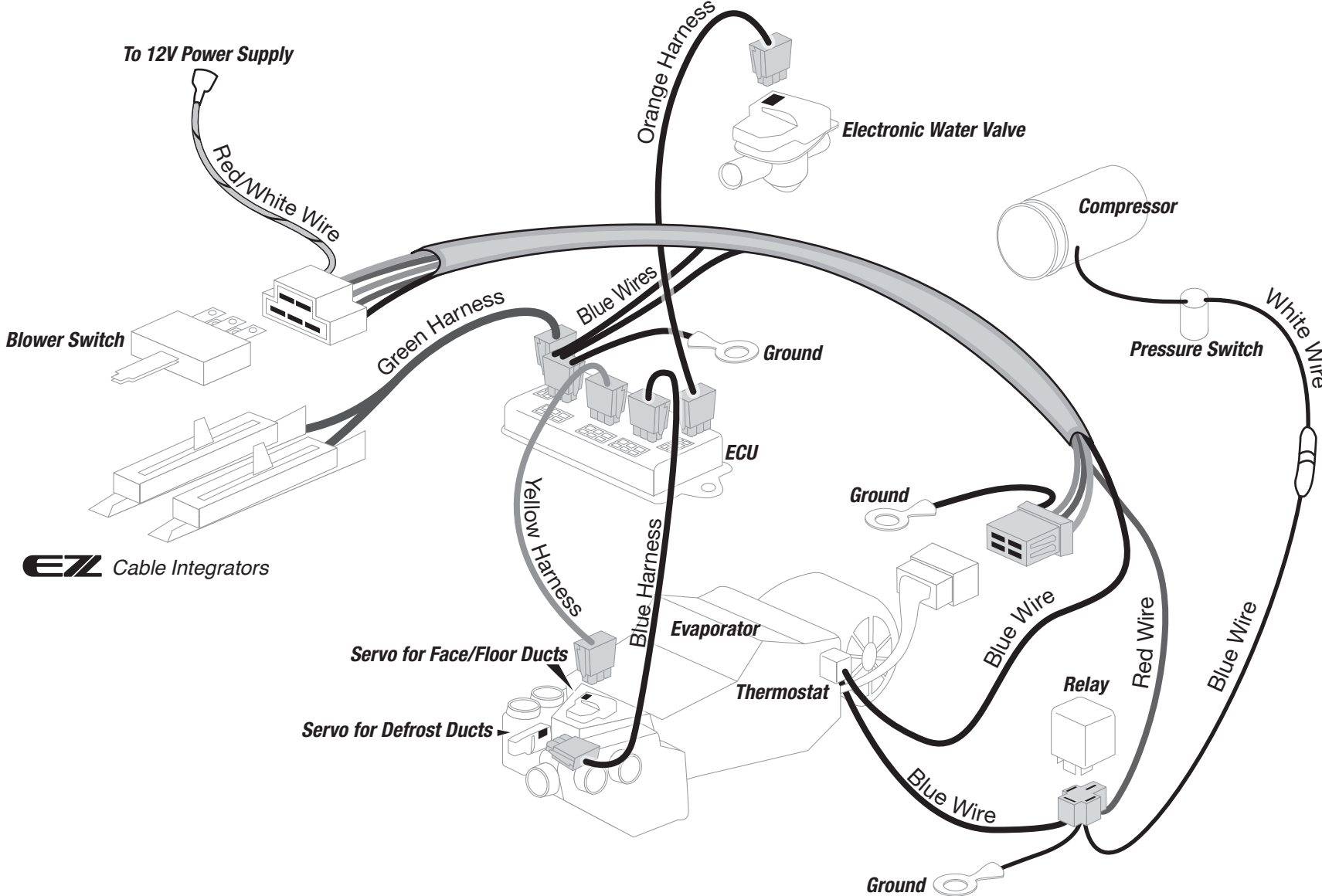

FIGURE 25



Wiring Diagram/Overview



EZ Cable Integrators

REMINDER: BE SURE THAT THE WIRING HARNESS DOES NOT INTERFERE WITH THE OPERATION OF ANY CONTROLS.



Temporarily reconnect the car battery at this time. You will need a full 12 volts to complete the calibration.

1967-68 Mustang EZ CALIBRATION... Follow these directions carefully and your unit will be calibrated in just a few minutes.

Before we boxed and shipped your unit, we tested and calibrated it to factory specifications to make sure it is capable of operating at maximum efficiency. However, the unit must still be calibrated to your specific vehicle and controls. This is an easy process that can be done in a few steps. If for any reason your unit does not calibrate properly the first time, just turn off the unit and rerun the setup process. **NOTE: When you move a knob to a new position, do it in ONE continuous motion.**

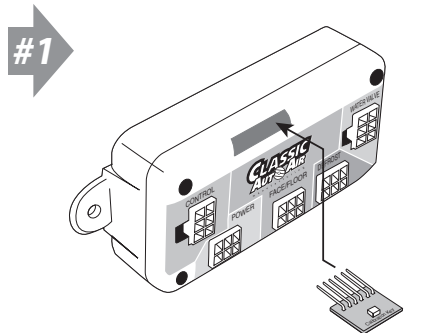

Plug CALIBRATION KEY into ECU

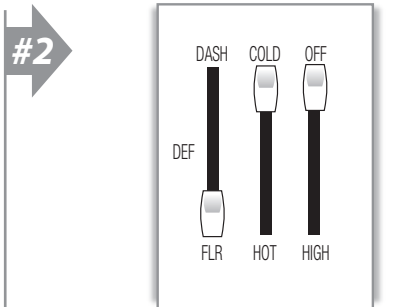

Position your controls like this example.

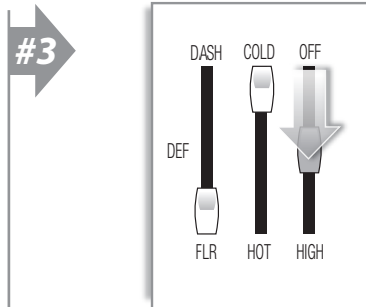

Move FAN control to medium in one motion...

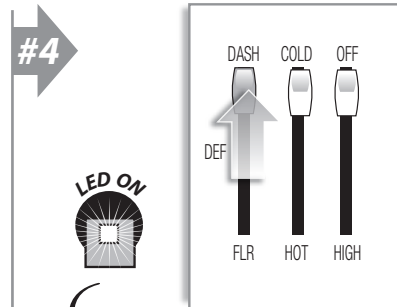
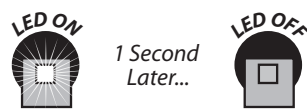

Move MODE control to DASH in one motion...

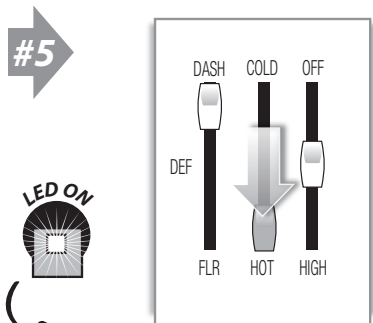

Move TEMP control to COOL in one motion...

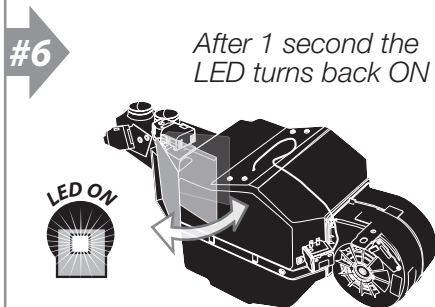

After 1 second the LED turns back ON



You may be able to hear the internal door(s) move back and forth...

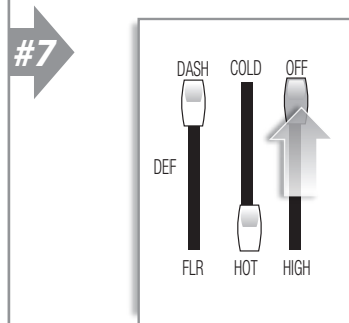

Move the FAN knob to OFF (powers off unit)

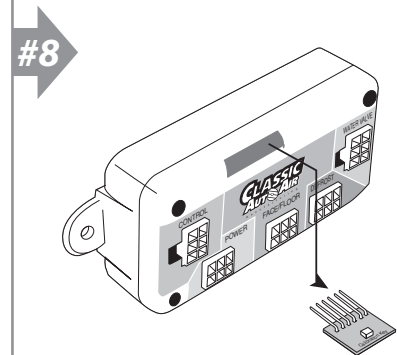

REMOVE KEY AND STORE IN SAFE PLACE

That's it. Your unit is now fully calibrated. Disconnect the battery and move on to the next phase....

THESE ARE THE PARTS YOU WILL FIND IN BAG KITS E, F, and G

You will use all of these parts and hardware during the next series of installation steps.

Bag E

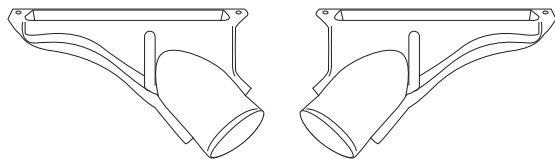

*Left and Right Side Defrost Vents
PN#0019-64 0019-63*

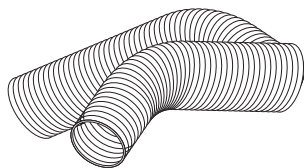

Two Duct Hoses, 2" I.D.



Four Zip-Ties

Bag F

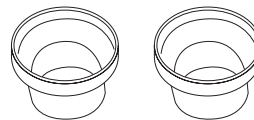

*Driver & Passenger Side Vent Adaptors
PN#03-1894*

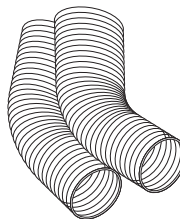

Two Duct Hoses, 2" I.D.

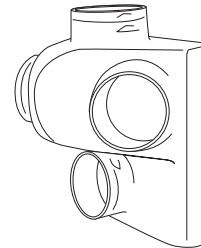

*Face Duct Assembly
PN# 2-1025-1*



Four Zip-Ties

Bag G

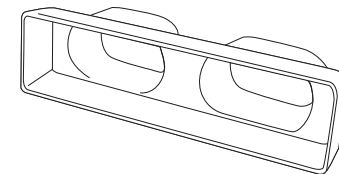

*Center Vent Adaptor
PN#0019-69*

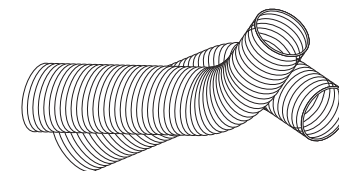

Two Duct Hoses, 2" I.D.



Four Zip-Ties

Illustrations NOT shown actual size

Bag Kit E. The following steps are for the left and right Defrost Diffusers... Locate and route the duct hoses from the defrost/heat duct assembly upward toward the top of the dash. Using the OEM screws from the OEM defrost vents, install the new defrost vents we provided and attach the flex hose to them using zip-ties. The other end of the duct hose is installed over the defrost/heat duct assembly outlets on the main unit (see figure 27).

The face duct assembly comes with s-clips pre-installed which allow you to install it onto the evaporator unit quickly and securely (see figure 28).

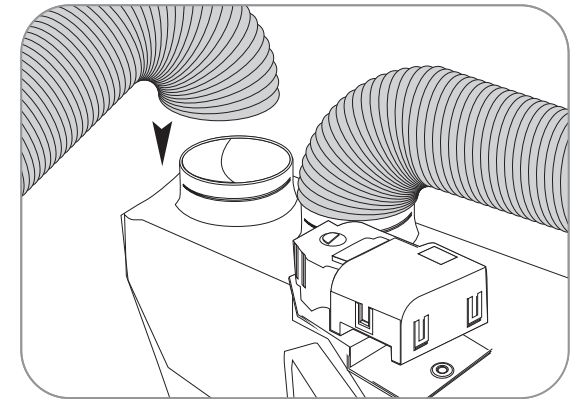

FIGURE 27

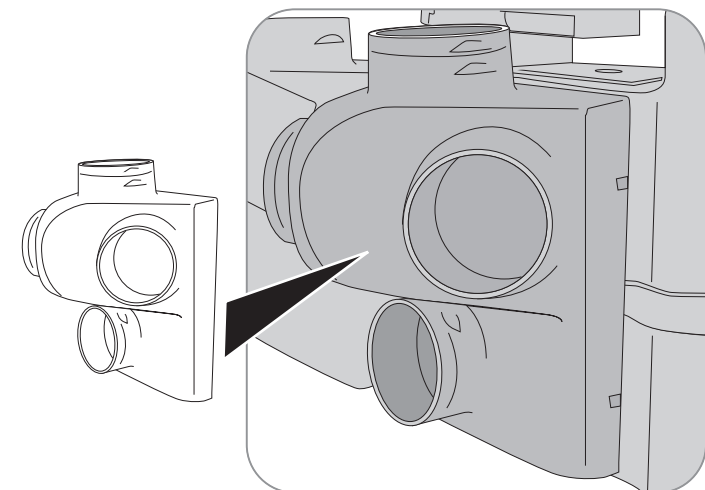
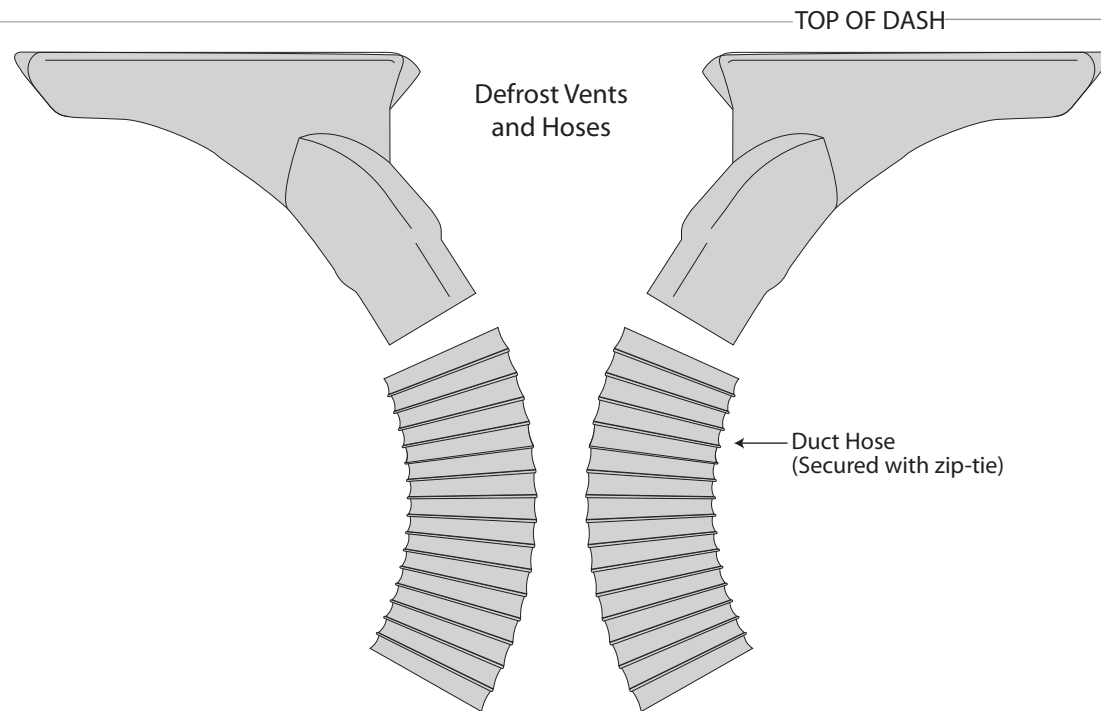
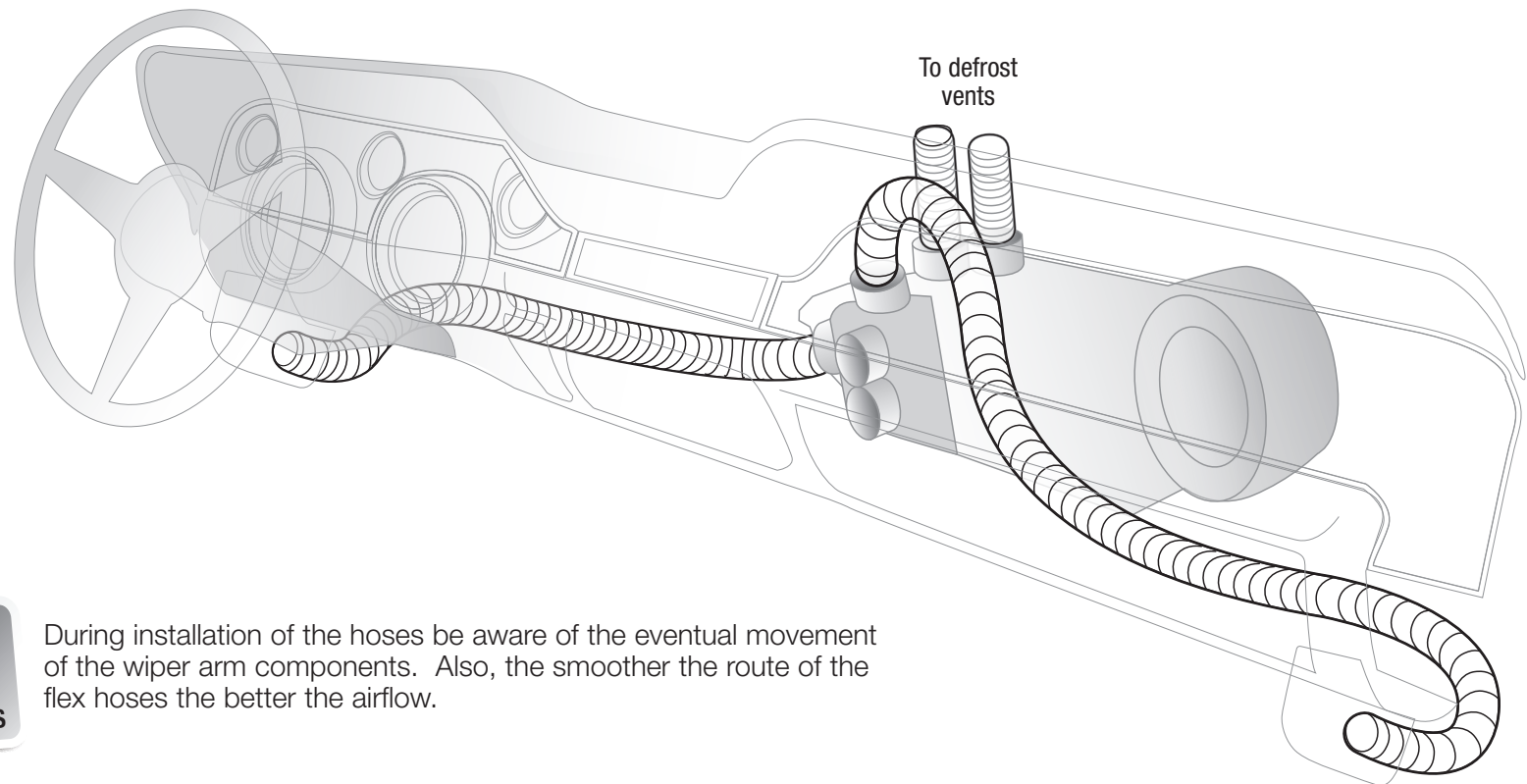

FIGURE 28

Bag Kit F: Attach the supplied vent adaptors to the driver and passenger lower side vents, and then attach and route the hoses as shown below to your OEM vents. Use the supplied zip-ties to secure the hoses.

Take your time and route the hoses so they don't become kinked or torn.



During installation of the hoses be aware of the eventual movement of the wiper arm components. Also, the smoother the route of the flex hoses the better the airflow.

Bag Kit G: The final step in the flex hose routing is for the center vent. We've included a center vent adaptor which you can attach to your OEM vent, then secure the flex hoses with zip-ties and route as shown below.

You can reinstall the glove box at this time. If your vehicle was equipped with a center console (which you removed earlier), you may need to modify it (see figure 31) before reinstallation. Test fit your particular console before cutting.

This completes the interior portion of the **PERFECT FIT-ELITE** installation process. This is a good time to make a final check that all the controls still move freely and that nothing is loose or hanging down.

The interior of your car should look pretty much the same as before you started (or better). Plus you probably got to know the underside of your dash a lot better and might even have repaired or upgraded components that needed attention.

Good Job... Let's move on to the major components within the engine compartment....

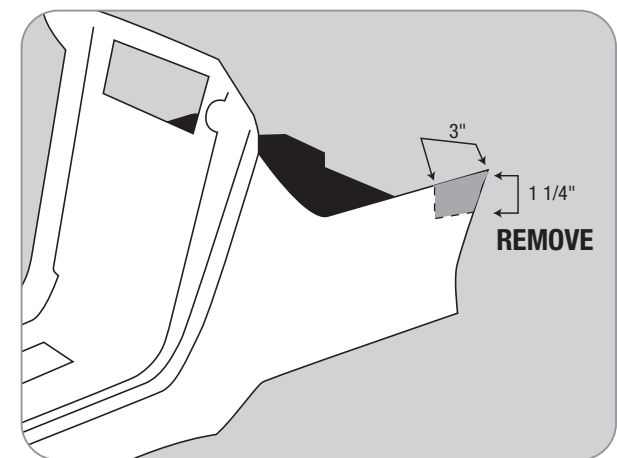
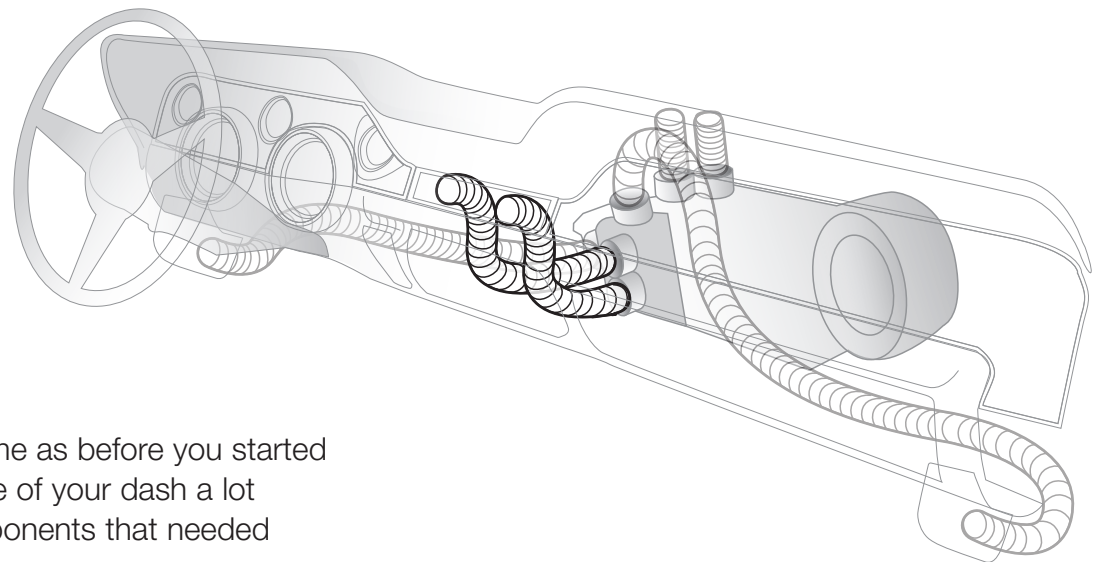
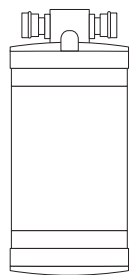

FIGURE 31

THESE ARE THE PARTS YOU WILL NEED FOR THE ENGINE COMPARTMENT INSTALLATION

You'll find all of these parts within the main box



Drier

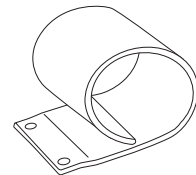

Drier Bracket

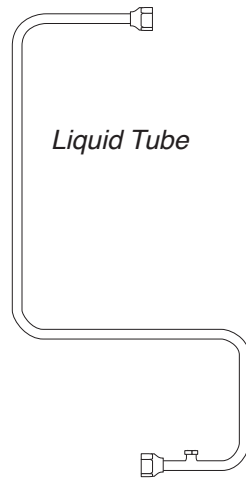

Liquid Tube

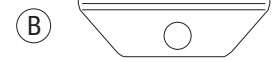
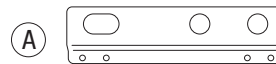

Condenser Brackets

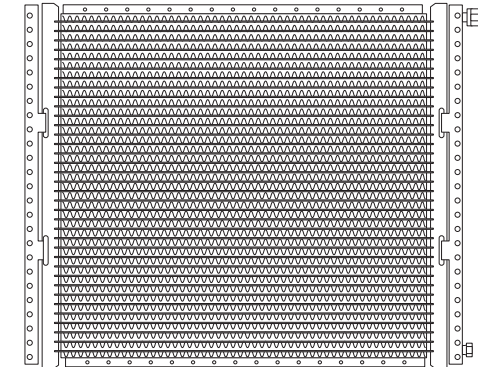

Condenser

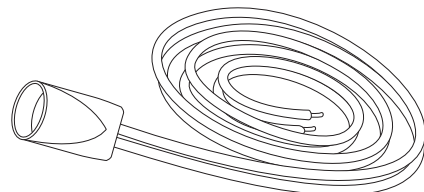

Pressure Switch Harness

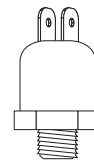

Pressure Switch

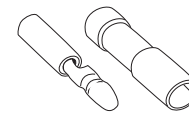

Splice and Bullet Connector



Four Zip-Ties

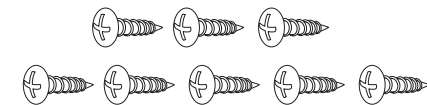

Eight #10 - 20x5/8" Screws

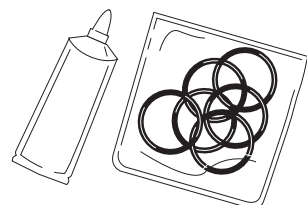

Bag of O-rings and Mineral Oil Tube

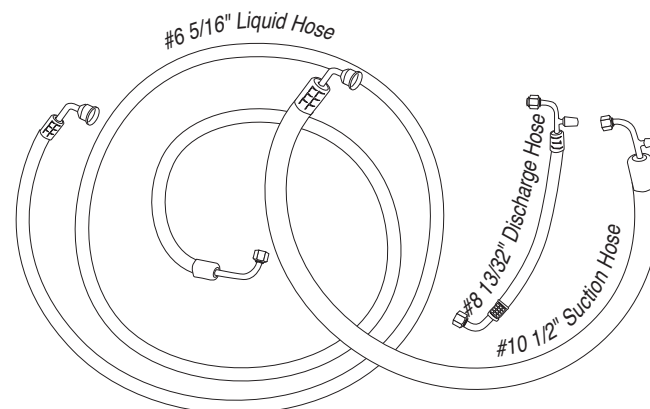

Three Refrigerant Hoses



Two #8 - 20 x 5/8" Bolts and Lock Nuts



ENGINE COMPARTMENT INSTRUCTIONS

STEP ONE: IF YOU HAVE NOT DONE SO ALREADY, DISCONNECT THE BATTERY.

STEP TWO: During the next steps you'll be installing the condenser, drier, and routing the refrigerant hoses along with the hi/low safety switch. Since much of this is installed in the OEM location for the condenser, you'll need to remove the center grill section, horn(s), and latch support assembly (see figure 32). Be sure to retain all the mounting screws – you'll reinstall these pieces in the exact reverse order with the OEM screws.

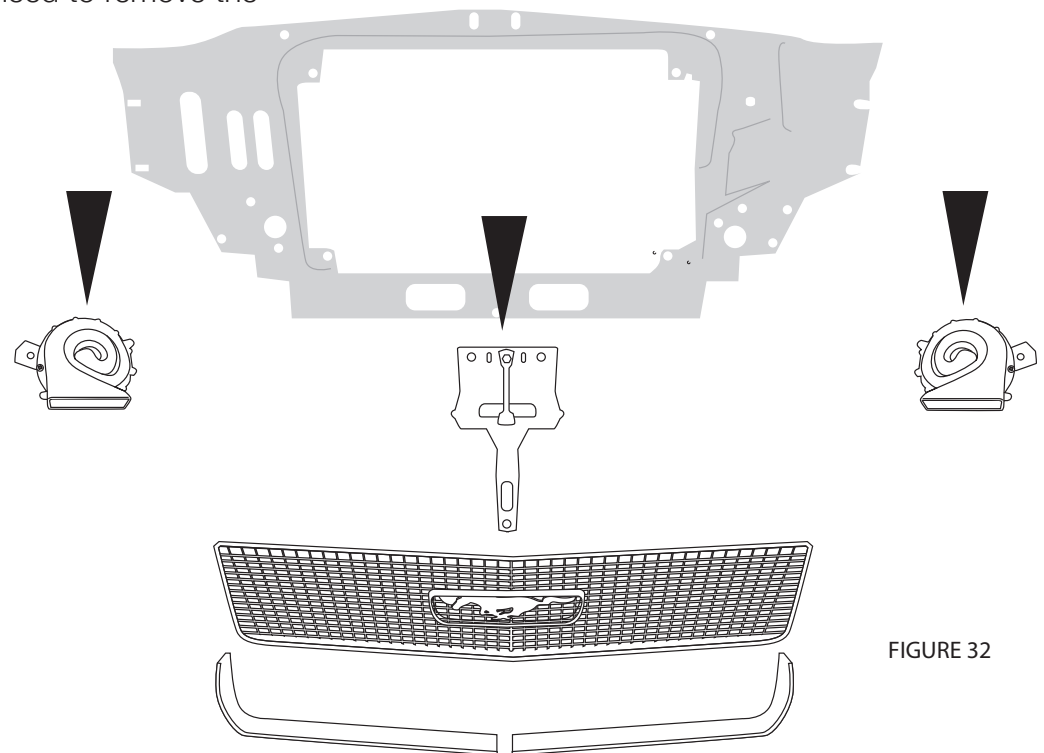

FIGURE 32

STEP THREE: DRIER AND CONDENSER PREPARATION. You can perform most of the following steps on a clean flat surface like a workbench. Lay the condenser down so that both hose connections are on the right side (the larger connection will be on top). The drier is conveniently mounted on the right hand side of the condenser. First insert the drier into the drier mounting bracket (it's basically a sleeve for the drier). Attach the drier liquid tube to the drier and also to the connection on the condenser (tighten connections at either end using supplied o-rings on both ends and a few drops of mineral oil to each o-ring). With these two components combined it will be easy to find the correct place to attach the drier bracket to the condenser with the included #8-20 x 5/8" bolts and lock nuts (attach drier and bracket from the back of the condenser).

STEP FOUR: Screw the high-pressure switch into the port at the lower end of the drier liquid tube. Go ahead and plug the pressure switch harness into the switch at this time (black electrical boot with two long white wires).

STEP FIVE: Install the upper condenser bracket (A) using four #10 - 20 x 5/8" screws in the 4th, 5th, 8th and 9th holes on the condenser from the left, be sure the bend on the bracket is facing towards you. Next, attach the lower bracket (B) using four #10-20 x 5/8" screws in the 5th, 6th, 9th and 10th hole from the left hand side. This bracket has a large hole that corresponds to the OEM latch support previously removed from the vehicle.



You can easily find the correct position for mounting the drier to the condenser by using the drier liquid tube as a gauge.

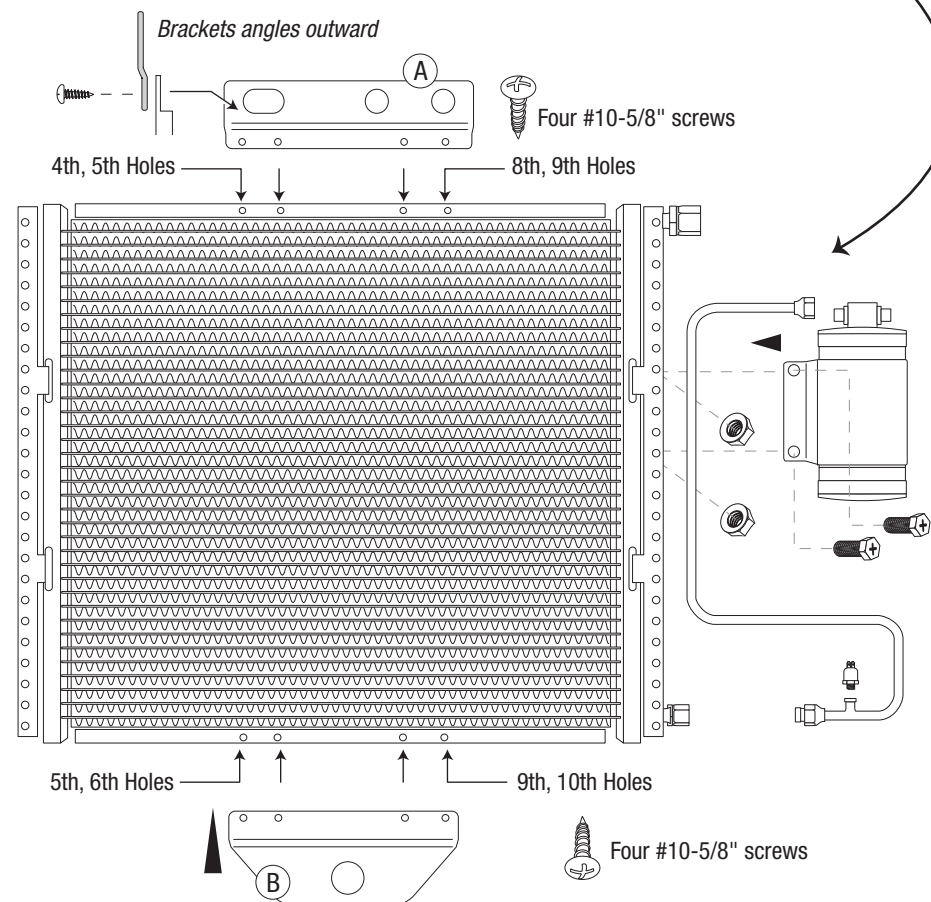

Reminder...
Use two wrenches to tighten o-ring fittings

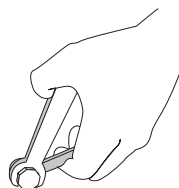

STEP SIX: You'll route the new discharge hose to the compressor thru the previously drilled hole in the radiator support, as well as the liquid hose and the wiring harness plug for the high/low safety switch (see figure 33).

STEP SEVEN: Place the condenser/drier unit into place, locating it so that the holes in the condenser brackets align with the holes in the core support used to attach the hood latch (it will rest on the lower radiator core brace, see figure 33).

STEP EIGHT: Time to install the compressor kit. Included in your box is a premium compressor kit with all the parts you'll need to install the compressor. This kit includes instructions specifically written for your engine. Once you've installed the complete compressor kit, continue on to connecting the hoses.

STEP NINE: CONNECTING THE HOSES:

1) Attach the #8 Discharge Hose (13/32") to the upper connection of the condenser and route thru the hole previously drilled in the core support and route to the compressor. Tighten fittings using o-rings and mineral oil provided.

2) Attach the #6 liquid hose (5/16") to the drier and route thru the remaining hole previously drilled into the core support and along the underside of the fender struts, around the engine, and to the connection at the firewall on the evaporator unit (see figure 40). Using supplied zip-ties you'll attach this hose, the suction hose and the lead from the high pressure switch to the strut braces, securing all three at once. Tighten fittings using o-rings and mineral oil supplied in kit.

3) Attach the #10 suction hose (1/2") to the compressor and route as mentioned above. Tighten fittings using o-rings and mineral oil supplied in the kit.

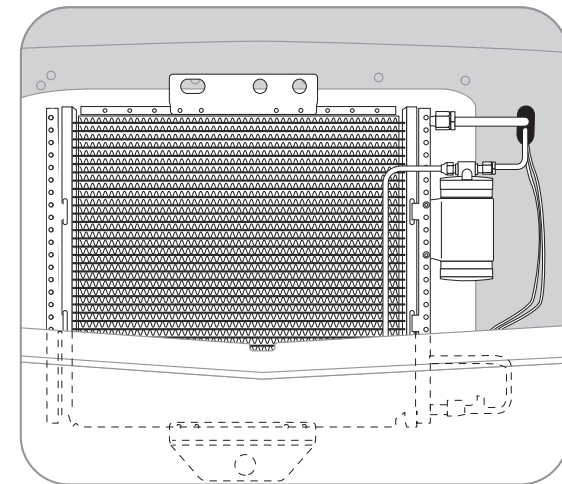

FIGURE 33

STEP TEN: Connect the pressure switch by first connecting one wire to the connection on the compressor, and the other wire will be routed along with the liquid hose along the underside of the fender supports and connected to the blue lead you put thru the firewall during the interior installation (for attachment route, see figure 34). We've included a bullet and slice connector to make these connections, use a crimp tool to secure these properly.

FINAL STEPS: You can now complete this portion of the installation by reinstalling the grill, horns, and latch support in reverse order. **NOTE:** The OEM screws for the hood latch support will hold your new condenser in place, so be sure to fully tighten these during this step. Take a look around at your installation and check all fittings and bolts for tightness, check the heater hose clamps for tightness, and make sure nothing is routed in a way to obstruct any moving parts. **You can refill the radiator and reconnect the battery at this time.**

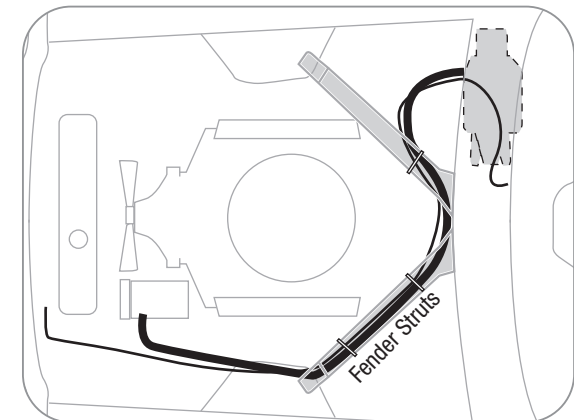

FIGURE 34

**WAY TO GO! You've just completed the installation of your new A/C system.
The very final step is to fully charge and test your new system.**

**On the next page you'll find specifications for proper final preparation
for your A/C technician.**

New A/C System Preparation... A MUST READ!

Please read thru these procedures before completing this new A/C system charging operation.

A licensed A/C technician should be utilized for these procedures to insure that your new system will perform at it's peak, and that your compressor will not be damaged.

- 1) Your radiator/cooling system is an integral part of your new system. Please insure that you have a 50/50 mix of distilled water and antifreeze. The heater coil **MUST** be purged (cycle heater control valve) to make sure no water, without antifreeze, is in the heater coil before you charge the A/C system.
- 2) Evacuate the system for 45 minutes (minimum).
- 3) **Your new compressor MUST be hand-turned 15-20 revolutions before and after charging with liquid. Failure to do this may cause the reed valves to become damaged** (this damage is NOT covered by your warranty).
- 4) Your new system requires 134a refrigerant. It will require 1.5 lbs (or 24 oz).
- 5) Your new compressor comes charged with oil - NO additional oil is needed.
- 6) Insure that the new belt is tight.
- 7) **DO NOT CHARGE SYSTEM WITH LIQUID WHILE THE ENGINE IS RUNNING!**

RECOMMENDED TEST CONDITIONS: (After system has been fully charged and tested for basic operation)

- Determine the temperature outside of the car
- Connect gauges or service equipment to high/low charging ports
- Place blower fan switch on medium
- Close all doors and windows on vehicle
- Place shop fan directly in front of condenser
- Run engine idle up to approx. 1500 rpm

ACCEPTABLE OPERATING PRESSURE RANGES:

1. HIGH-SIDE PRESSURES (150-250 PSI)
2. LOW-SIDE PRESSURES (15-25 PSI in a steady state)

Readings above are based on an ambient temperature of 90° with an adequate airflow on condenser

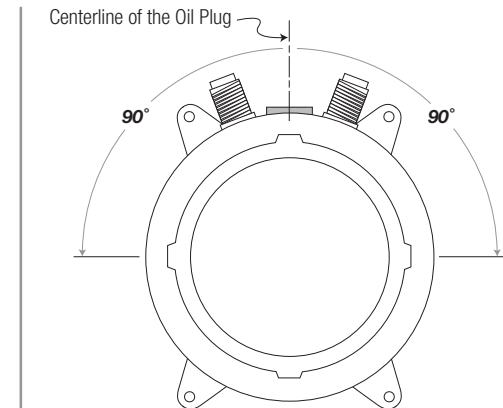

CAUTION! When mounting your compressor and/or adjusting the belt, use caution not to tilt the compressor up to or more than 90° off the centerline of the oil fill plug. This can cause compressor failure.

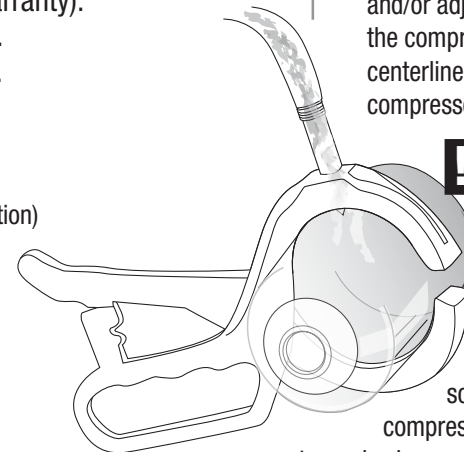

! Do **NOT** tilt, shake or turn refrigerant can upside-down OR use a charging station to install refrigerant while the engine is running. Doing

so will direct liquid refrigerant into the compressor piston chamber, causing damage to reed valves and/or pistons and/or other components, as well as potentially seizing the compressor. Allow a minimum of 30 minutes for liquid to "boil off." You must hand turn the compressor hub (not the pulley) a minimum of 15 complete revolutions prior to starting the engine with the clutch engaged.

TROUBLESHOOTING GUIDE

TEST CONDITIONS USED TO DETERMINE SYSTEM OPERATION

(THESE TEST CONDITIONS WILL SIMULATE THE AFFECT OF DRIVING THE VEHICLE AND GIVE THE TECHNICIAN THE THREE CRITICAL READINGS THAT THEY WILL NEED TO DIAGNOSE ANY POTENTIAL PROBLEMS).

- B. CONNECT GAUGES OR SERVICE EQUIPMENT TO HIGH/LOW CHARGING PORTS.
- C. PLACE BLOWER FAN SWITCH ON MEDIUM.
- D. CLOSE ALL DOORS AND WINDOWS ON VEHICLE.
- E. PLACE SHOP FAN IN FRONT OF CONDENSER.
- F. RUN ENGINE IDLE UP TO 1500 RPM.

ACCEPTABLE OPERATING PRESSURE RANGES (R134A TYPE)

- 1. HIGH-SIDE PRESSURES (160-250 PSI) **Note- general rule of thumb is two times the ambient (daytime) temperature, plus 15-20%.*
- 2. LOW-SIDE PRESSURES (06-22 PSI in a steady state).

CHARGE AS FOLLOWS: R134A = 24 OZ.

NO ADDITIONAL OIL IS NECESSARY IN OUR NEW COMPRESSORS.

TYPICAL PROBLEMS ENCOUNTERED IN CHARGING SYSTEMS

NOISY COMPRESSOR. A noisy compressor is generally caused by charging a compressor with liquid or overcharging

- A. If the system is overcharged both gauges will read abnormally high readings. This is causing a feedback pressure on the compressor causing it to rattle or shake from the increased cylinder head pressures. System must be evacuated and re-charged to exact weight specifications.
- B. **Heater control valve installation** - Installing the heater control valve in the incorrect hose. Usually when this occurs the system will cool at idle then start to warm up when raising the RPM's of the motor. **THE HEATER CONTROL IS A DIRECTIONAL VALVE; MAKE SURE THE WATER FLOW IS WITH THE DIRECTION OF THE ARROW.** As the engine heats up that water transfers the heat to the coil, thus overpowering the a/c coil. A leaking or faulty valve will

have a more pronounced affect on the unit's cooling ability. Installing the valve improperly (such as having the flow reversed) will also allow water to flow through, thus inhibiting cooling. Check for heat transfer by disconnecting hoses from the system completely. By running down the road with the hoses looped backed through the motor, you eliminate the possibility of heat transfer to the unit.

- C. **Evaporator freezing** - Freezing can occur both externally and internally on an evaporator core. External freeze up occurs when the coil cannot effectively displace the condensation on the outside fins and the water forms ice (the evaporator core resembles a block of solid ice), it restricts the flow of air that can pass through it, which gives the illusion of the air not functioning. The common cause of external freezing is the setting of the thermostat and the presence of high humidity in the passenger compartment. All door and window seals should be checked in the event of constant freeze-up. A thermostat is provided with all units to control the cycling of the compressor.
- D. **Internal freeze up** occurs when there is too much moisture inside the system. The symptoms of internal freeze up often surface after extended highway driving. The volume of air stays constant, but the temperature of the air gradually rises. When this freezing occurs the low side pressure will drop, eventually going into a vacuum. At this point, the system should be checked by a professional who will evacuate the system and the drier will have to be changed.
- E. **Inadequate airflow to condenser** - The condenser works best in front of the radiator with a large supply of fresh air. Abnormally high pressures will result from improper airflow. Check the airflow requirements by placing a large capacity fan in front of the condenser and running cool water over the surface. If the pressures drop significantly, this will indicate the need for better airflow.
- F. **Incorrect or inadequate condenser capacity** - Incorrect condenser capacity will cause abnormally high head pressures. A quick test that can be performed is to run cool water over the condenser while the system is operating, if the pressures decrease significantly, it is likely a airflow or capacity problem.
- G. **Expansion valve failure** - An expansion valve failure is generally caused by dirt or debris entering the system during assembly. If an expansion valve fails it will be indicated by abnormal gauge readings. A valve that is blocked will be indicated by high side that is unusually high, while the low side will be unusually low or may even go into a vacuum. A valve that is stuck open will be indicated by both the high and low pressures rising to unusually high readings, seeming to move toward equal readings on the gauges.
- H. **Restrictions in system** - A restriction in the cooling system will cause abnormal readings on the gauges. A high-side restriction (between the compressor and the drier inlet) will be indicated by the discharge gauges reading excessively high. These simple tests can be performed by a local shop and can help determine the extent of the systems problem.

Trouble Shooting Your Classic Auto Air A/C System

PROBLEM: system is not cooling properly
ISSUE: cold at idle, warmer when raising engine RPM's

Make sure the Water Valve is positioned correctly

The water valve is a directional valve and should be installed with the arrow pointing towards the water pump, it should be connected to the heater hose that runs from the heater core to the water pump. If the water valve is connected to the incorrect hose it allows water to circulate through the system via the heater core over powering the cooling effect of the A/C coil, (normally the air conditioning is functioning properly).

Step 1: Check placement of the water valve, correct if needed. (In some cases changing the location of the water valve may not fix the above problem.) Continue to next step.

Step 2 If changing the location of the water valve does not rectify the issue, then possibly the water valve is permanently damaged and may need to be replaced. To check the integrity of the water valve completely remove the water hoses for the heater core and "loop" together. (This will remove the heater system completely from the possibilities) If the system now cools, replace the water valve

Verify Adequate Air Flow to Condenser

For an air conditioning system to function properly there has to be adequate airflow across the condenser. The function of the condenser is to dissipate heat, without proper airflow your system will not cool correctly in the cabin of your vehicle.

Step 1: connect gauges to a/c hoses. The pressures should be: with the ambient temp is 90, low side pressures should be between 8-25 psi, high side pressures should be between 160-260psi

Step 2: IF the low side pressures are normal and the high side pressures are high then there might be an airflow issue, continue to next step.

To test air flow to Condenser do the following three tests:

1. Place a piece of paper on the condenser with the car in idle and see if paper is held in place.
2. With car in idle, attach gages, and place a large capacity fan in front of the condenser. What happens to the pressures?
3. With car still in idle and gages attached, pour water down the front of the condenser. What happens to the pressures?

If the paper is held in place you are at least getting some air flow. If the high side decreases during test 2 & 3 then your condenser is not getting enough air which is causing your system to not cool properly. To correct this issue you will need a more powerful mechanical fan.

Step 3: Confirm correct Refrigerant charge in System

All of our systems should be charged with 24oz or 1.8lbs of R134 Refrigerant only. If overcharged you will need to evacuate the system and recharge with the correct amount.*

What measurements mean:

Low Temp and High Pressure seem to be equal...

You have a malfunctioning expansion valve that is stuck open.

High Side is extremely high and Low Side is extremely low (possibly into vacuum)...

There is a blockage in the system. Remove hoses and blow compressed air through in both directions. If pressures don't change its possible that your expansion valve is stuck closed and would have to be replaced.

***Compressor Concerns:**

This is often misdiagnosed as a problem for the system not cooling properly. If you have a noisy compressor it is due to improper charging of refrigerant. An overcharged (more than 24oz or 1.8lbs R134) compressor can cause rattling. If charged with pure liquid there is a high probability you have bent reed valves that are causing tapping sound.

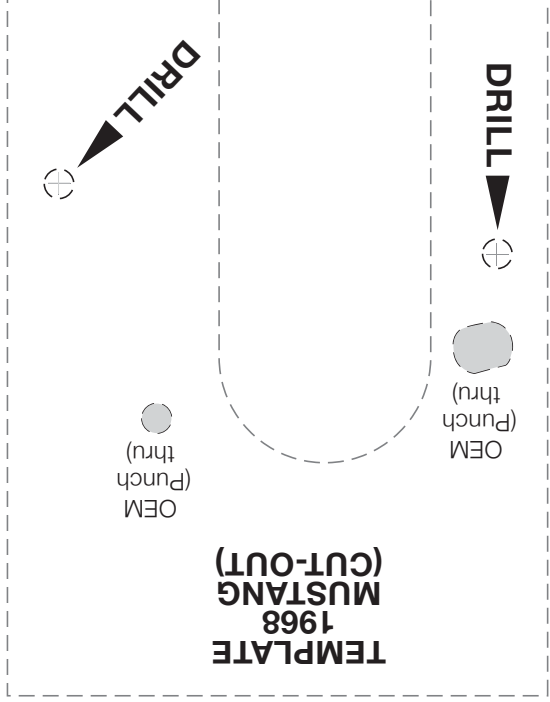

IF YOU PRINTED THIS MANUAL
PLEASE READ THIS...
 Just as a cautionary step, please
 measure this box and make sure it
 is 1" x 1". Some copiers/printers
 may not print at 100% of actual size.

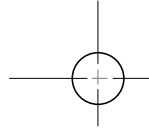
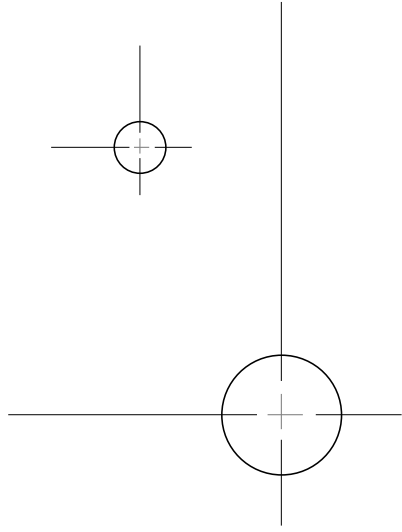

Note: bottom of template is parallel with floor pan

