

Installation Manual

1969-1970 Mustang

DOCUMENT #1-2027

©2013 ClassicAutoAir / 3.13vs1





Congratulations...

You have just purchased the highest quality, best performing A/C system ever designed for your Mustang.

To obtain the high level of performance and dependability our systems are known for, please pay close attention to the following instructions. Our installation steps and procedures are derived from a long history of research and development and the combined experience achieved thru thousands of successful installations (and feedback from customers like you). Please remember that our #1 goal is that you'll have a successful installation and a system that performs at a very high level for many years to come.

Before starting, read the instructions carefully, from beginning to end, and follow the proper sequence. On the next page you'll find a safety and general checklist that you should read before starting your installation.

Again, thank you from our entire staff.



Check List, Pre-Installation:

- Before beginning the installation check the shipping box for the correct components. YOUR BOXED UNIT INCLUDES A LIST OF MAJOR COMPONENTS AND A LIST OF BAGGED PARTS. We have a 5 stage check process to make sure you have everything you'll need.
- If your vehicle has been or is being modified, some procedures will need to be adjusted to fit your particular application.**
- A basic cleaning of the engine compartment and interior before beginning will make things go more smoothly.
- Check condition of engine mounts. Excessive engine movement can damage hoses to A/C and/or heater.
- Before starting, check vehicle interior electrical functions (interior lights, radio, horn, etc). Make a note of anything that does not work as it's supposed to. During the installation you might find the opportunity to repair or upgrade non-working or out of date components. When you're ready to start the installation, **DISCONNECT THE BATTERY FIRST.**
- Drain the radiator. Retain the coolant and reuse, or dispose of properly.
- SAFETY FIRST: Wear eye protection while drilling/cutting, deburr sharp edges, and never get in a hurry or force a part.
- Tools: Your installation only requires the basic tools everyone has in their garage, nothing exotic or specific to A/C or Heat equipment.

Procedures, During Installation:

- Fittings: Use one or two drops of mineral oil (supplied with your kit) on ALL rubber o-rings, threads and rear of bump for o-ring where female nut rides. Do not use thread tape or sealants.
- Measure twice (or more), cut once
- Should you have any technical questions, or feel you have defective components (or missing items), call us immediately, we will be glad to assist you. Our toll-free number is listed on every page, we're here to help!**

YOU CAN NOW BEGIN THE INSTALLATION...

A Basic A/C Overview

- 1 Evaporator with Blower Fan** In order to remove the heat from the air in the vehicle, the A/C evaporator allows the refrigerant to absorb the heat from the air passing over it. The blower fan moves cool air out into the car interior.
- 2 Compressor** The compressor pumps and circulates the refrigerant through the system.
- 3 Condenser** The condenser is a heat exchanger mounted at the front of the vehicle. Heat drawn out of the interior of the car is expelled here.
- 4 Receiver/Drier** The drier not only dries refrigerant, it also filters the refrigerant and stores it under certain operating conditions.
- 5 High Pressure Switch** A pressure switch is used to shut down the system if high or low pressure is detected, basically it acts as a safety switch.

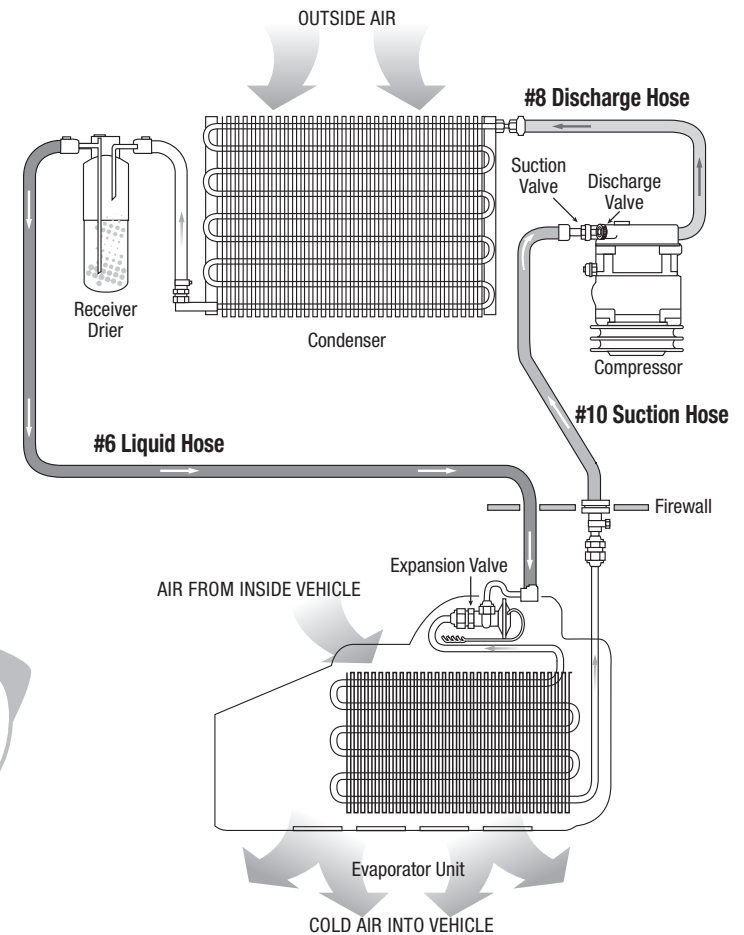
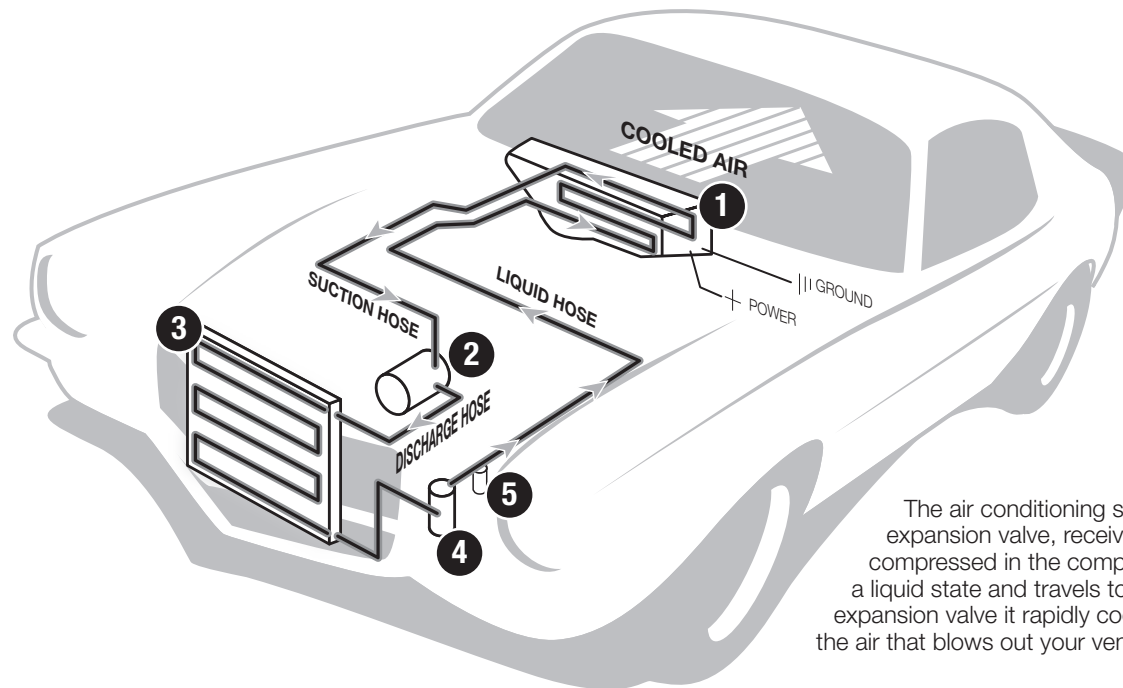

The air conditioning system in your car is comprised of a compressor, condenser, expansion valve, receiver/drier, and evaporator. Refrigerant (also known as Freon) is compressed in the compressor and turns into a gas. In the condenser, this gas is cooled to a liquid state and travels to the expansion valve. As the liquid refrigerant goes through the expansion valve it rapidly cools in the evaporator. A fan blows over the evaporator and cools the air that blows out your vents. The receiver-drier separates gas and liquid.

Control & Operating Instructions

Your new **Perfect Fit-Elite** system offers complete comfort capabilities in virtually every driving condition. This includes temperature control in all of the modes. This system also provides the ability to blend the air between Face, Heat, and Defrost modes simultaneously. To illustrate the various ways you can adjust the airflow direction and temperature - we've provided these handy illustrations and chart to show exactly how you can adjust your **Perfect Fit-Elite** for maximum comfort...



The **FAN** switch works like the OEM switch, the **DOWN** position is OFF (all power to the system is OFF in this position).

There are 11 levels of adjustment within the range of the **MODE** lever.

The **COLD/HOT** positions works like any traditional adjustment lever.

NOTE: When the **TEMP** lever is in the "FULL COLD" position the compressor is ON, no matter what position the **MODE** lever is in (think of it as a compressor-override function).

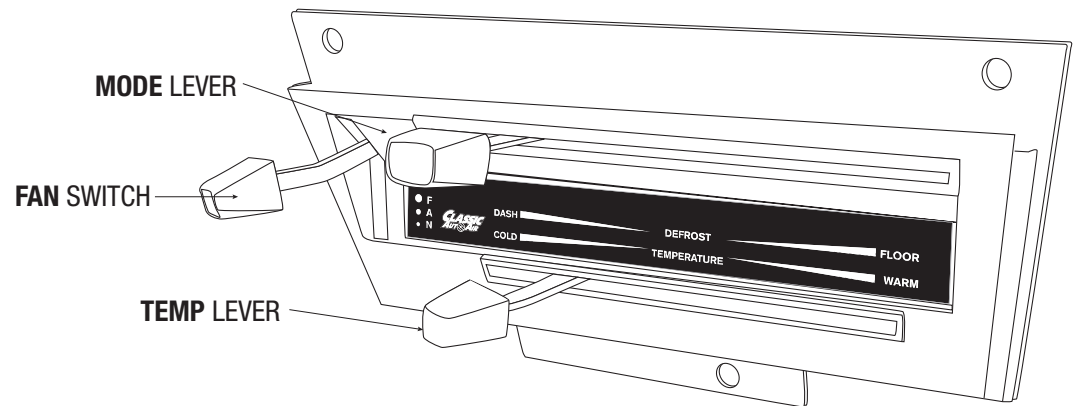

	DASH					DEF					FLOOR
Left Lever Position	1	2	3	4	5	6	7	8	9	10	11
Distribution	Face A/C 100%	Face 80% Defrost 20%	Face 60% Defrost 40%	Face 40% Defrost 60%	Face 20% Defrost 80%	Defrost 100%	Floor 20% Defrost 80%	Floor 40% Defrost 60%	Floor 60% Defrost 40%	Floor 80% Defrost 20%	Floor 100%
Compressor State	ON					ON					



Remove Glovebox, Console (if equipped), Facia, Radio and Bezel, and set them aside for reinstall later (see figure 1).

The removal of the Original Heater Assembly can be accomplished by disconnecting three control cables. One is attached to the Heat/Defrost door (see figure 2). One is attached to the Temperature door, and one is attached to the Vent / Heat door (see figure 3). Disconnect the electrical harness from the assembly. Also remove attachment screw located in front of the air inlet (see figure 4).

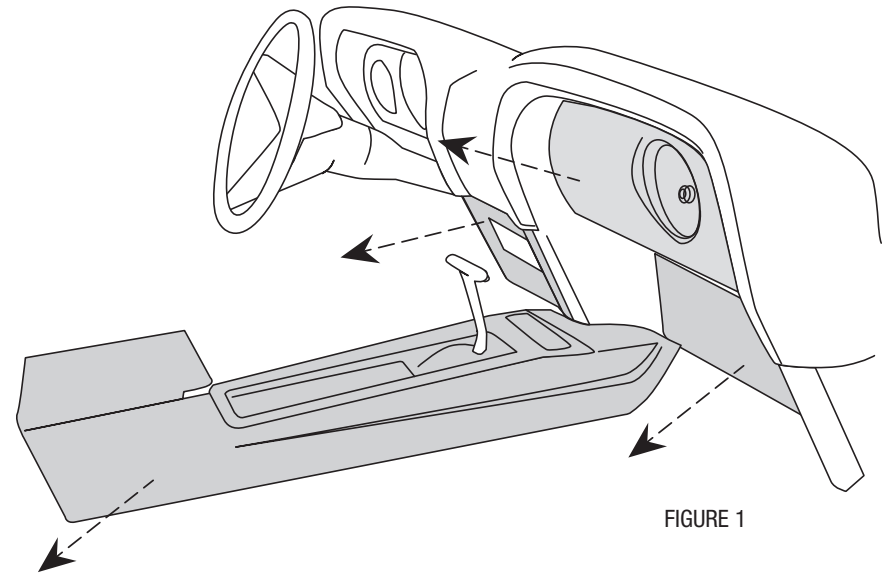

FIGURE 1



When retaining parts it's a good idea to store parts in a zip lock bag, labeled with info where the parts came from and what size/type of

tool is needed to reinstall. Cleaning the parts before you need to reinstall them is a good idea too.

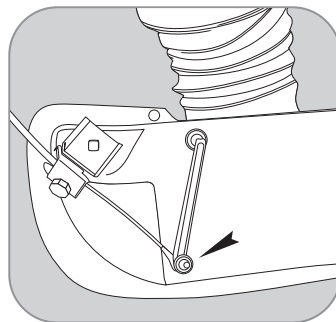

FIGURE 2

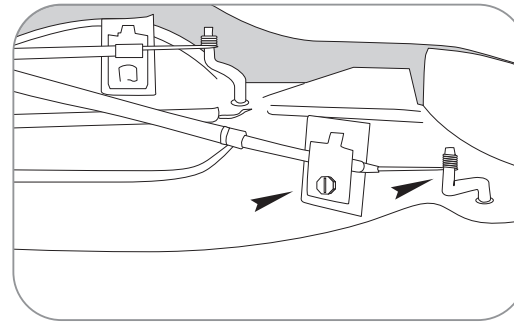

FIGURE 3

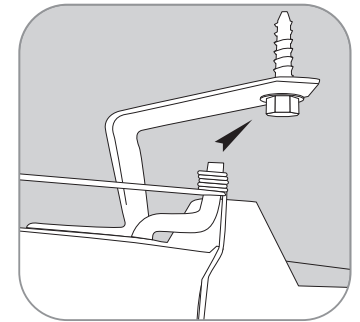
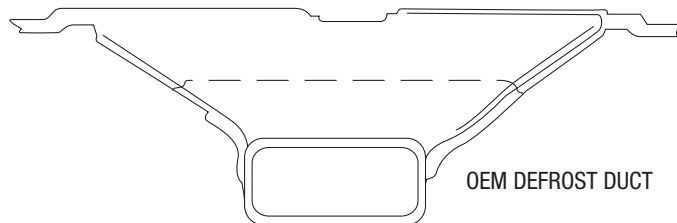

FIGURE 4

Locate blower motor on the firewall (Passenger Side) in the engine compartment. Remove all 4 nuts around blower. Also disconnect the electrical connector from the blower motor (see figure 5A). Cut wires at grommet in firewall.

Next, remove the OEM defrost duct and set aside for later modification.



DRAIN COOLANT FROM RADIATOR and store safely to reuse or recycle accordingly. Cut heater hose approximately 1" from firewall (see figure 5B). Also, to prevent forgetting to refill the coolant when the installation is completed, do not put the cap back into place - instead put the cap to the side and cover radiator hole with a clean rag or something similar (this will help remind you to add coolant before starting the engine at the end of the installation).

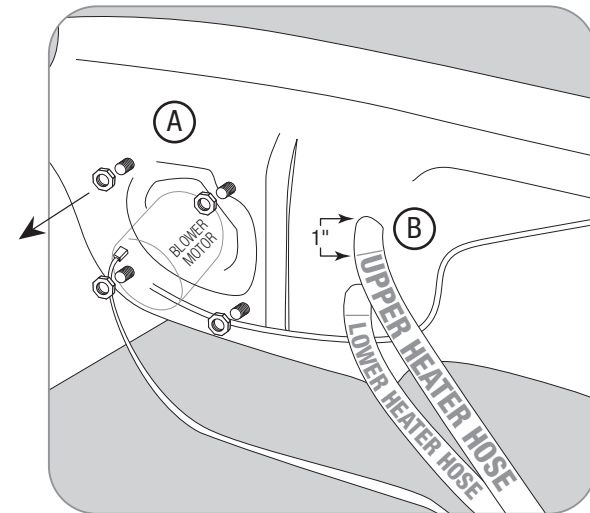

FIGURE 5

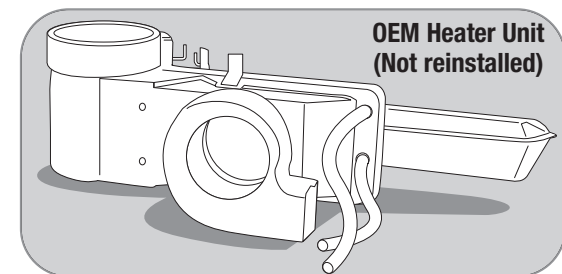
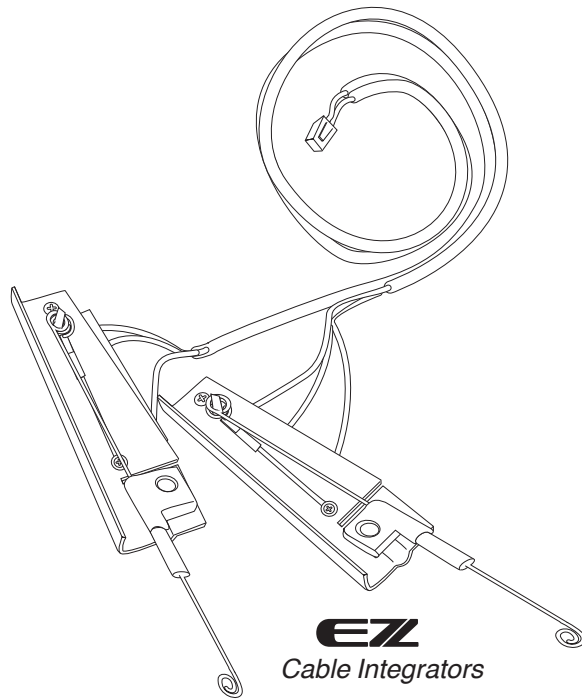

FIGURE 6

THESE ARE THE PARTS YOU WILL FIND IN BAG KIT A

You will use all of these parts and hardware during the next series of installation steps.



EZ
Cable Integrators

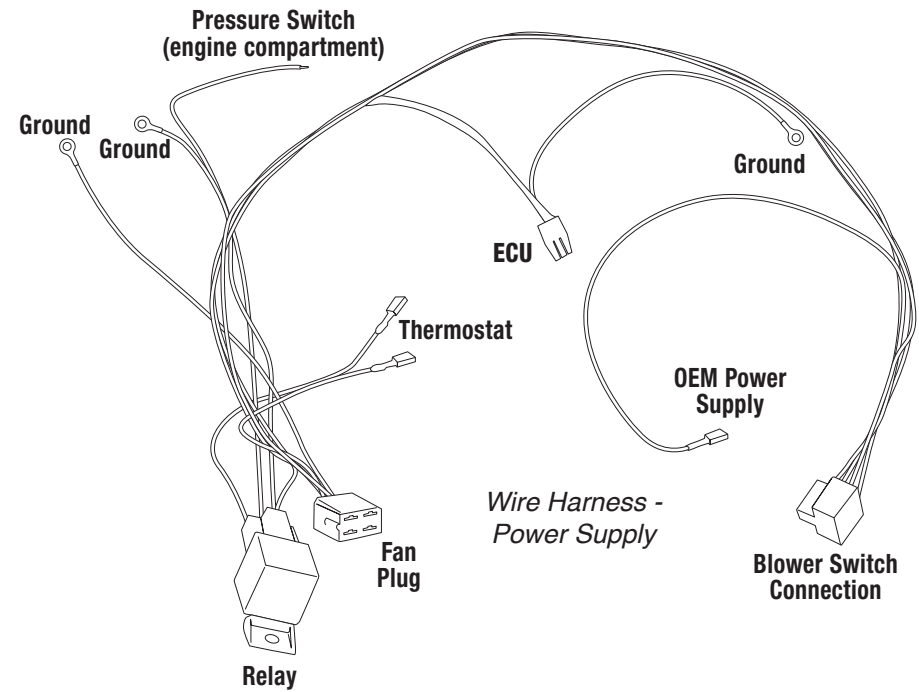

Faceplate Sticker
PN# 0118-3

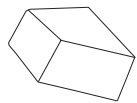

Blower Switch Knob
PN# 525325

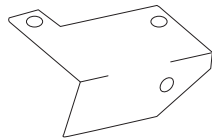

Blower Switch Bracket
PN# 0036-6

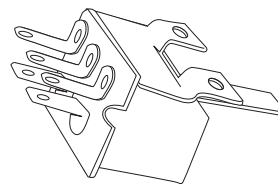

Blower Switch
PN# 3T235



Two #6 - 20x3/8" Screws

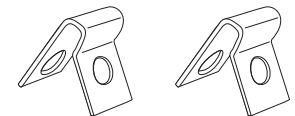

Two - Cable Clips
PN# 25-1015

NOTE: Illustrations NOT shown actual size

Remove The A/C Control Head From The Dash.

There are three OEM screws that hold your control head to the dash, one on the lower side and two on the upper. Remove and retain these screws. Remove the control head assembly.

Adapting your OEM control head to accept our exclusive EZ integrators is accomplished in a few easy steps:

STEP 1) Remove the OEM blower switch knob. Retain the screw, you will use it again shortly. Remove the control cables, the vacuum switch, and the original blower switch and set aside (these will not be reused, see figure 8). Remove the OEM control lever, then remove the tension clip and set it aside (control arm will not be used again). Move the tension clip to the new control arm (in the same orientation as the OEM), and put the new arm in place. Re-secure with the OEM c-clip (see figure 8).

STEP 2) Attach the new blower switch bracket to the top part of the back of the face plate (see figure 9-11), utilizing the OEM screw, and then attach the blower switch to the bracket with the two supplied #6 - 20x3/8" screws. Reinstall the switch knob.

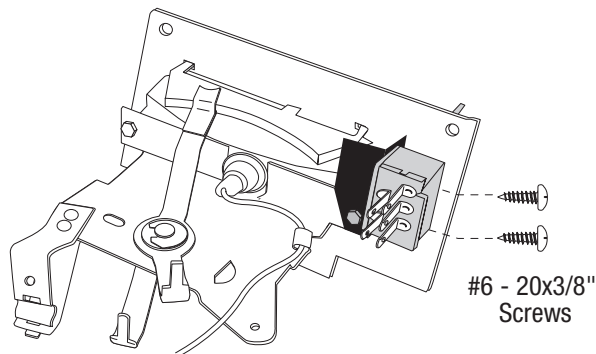
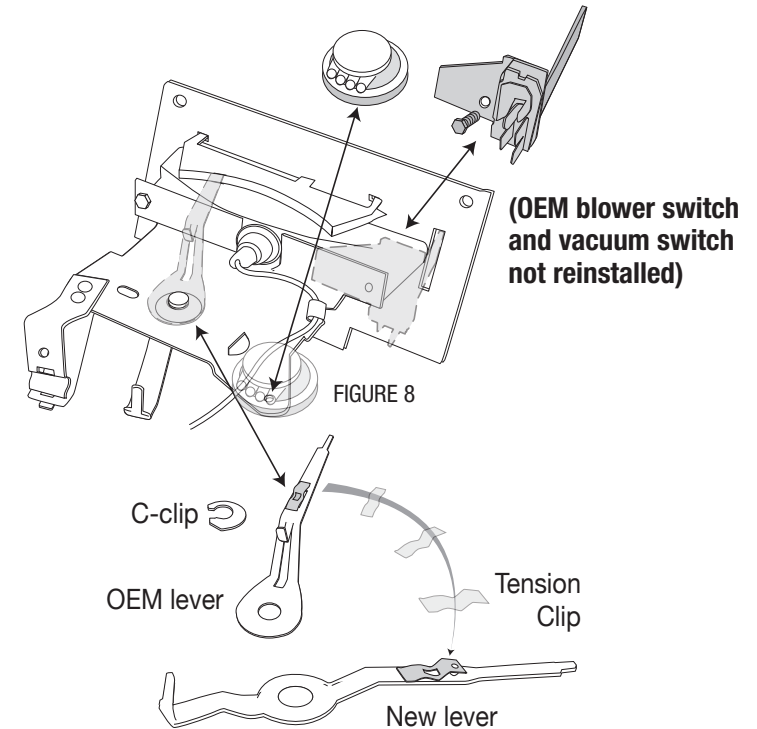

FIGURE 9

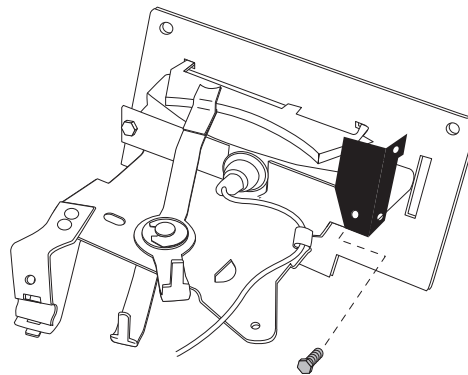

FIGURE 10

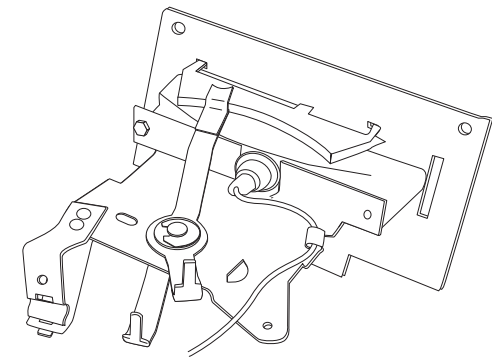

FIGURE 11

Preparing the TEMP EZ Cable Integrator for installation:

First place a cable clip over the end of the **Integrator** (see figure A). Press it firmly into place (using needle-nose pliers is recommended).

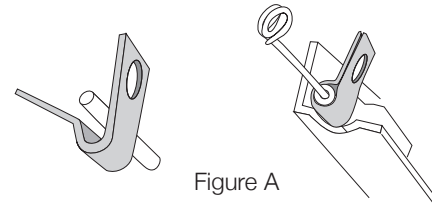

Figure A

Hook loop end of integrator wire over the end of the control head lever, see figure B.

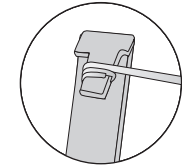

Figure B

Using the OEM screw mount the integrator to the control head pedestal as shown in figure D. Make sure orientation is correct, using figure C as a guide.

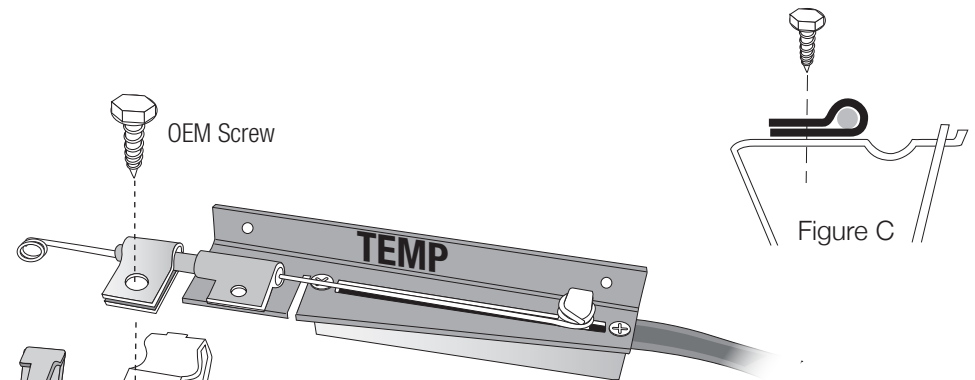

Figure C

Securely fasten wire end with a push nut (see figure E).

Lastly, move LOWER lever side to side making sure you have smooth operation of the cable integrator.

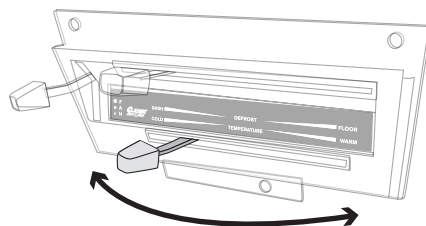

Figure E

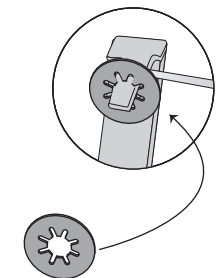

Figure D

Preparing the MODE EZ Cable Integrator for installation:

First place a cable clip over the end of the **Integrator**. Test fit into place first to make sure you have positioned correctly (see figure F). Press it firmly into place (using needle-nose pliers is recommended).

Hook loop end of integrator wire over the end of the control head lever. Placing integrator into place on pedestal (see figure F for orientation), mark thru the cable clip and drill a new hole into the side of the pedestal body using a 3/16" drill bit (see figure G). Attach integrator using an included #6 - 20x3/8 screw (see figure H).

Securely fasten wire end with a push nut (like on previous integrator). Move UPPER lever side to side making sure you have smooth operation of the cable integrator.

Lastly, we've included a new sticker you can place over your OEM faceplate. Make sure the surface is very clean and dry first.

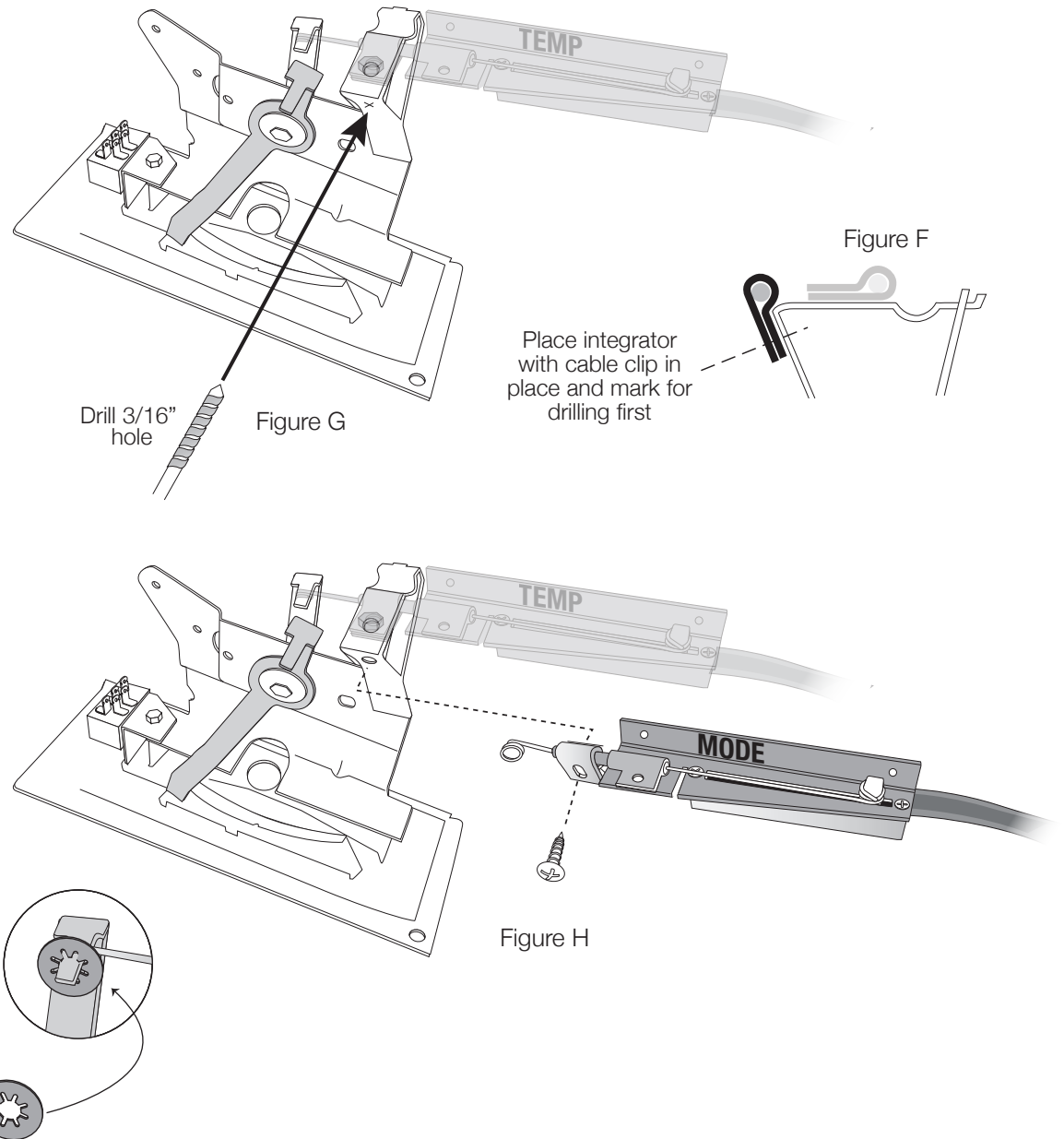

THESE ARE THE PARTS YOU WILL FIND IN BAG KIT B

You will use all of these parts and hardware during the next series of installation steps.

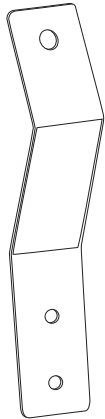

*Evaporator Support Bracket
PN# 0023-7*

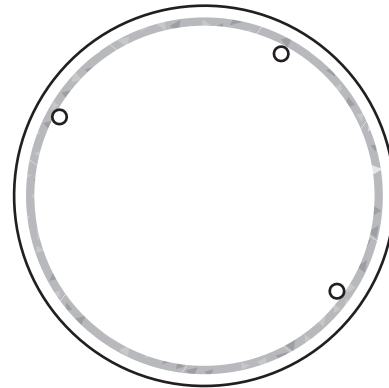

*One Fresh Air Inlet Block Off
PN# 10-1025-2*

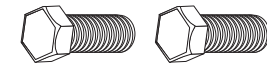

Two 1/4 - #20 x 5/8" Bolts

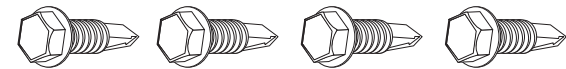

Four #10 - 16 x 3/4" Tek Screws

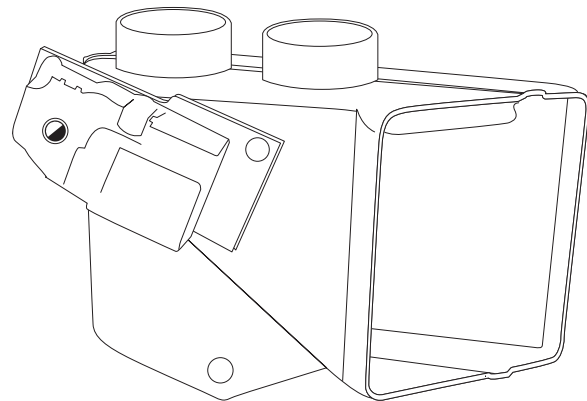

*Defrost/Heat Duct Assembly
PN# 2-2025-2*

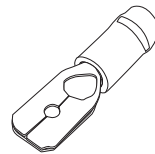

One Male Spade Connector



Four #10 - 10 x 5/8" Phillips Screws

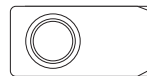

One J-Clip



One 1/2" Washer

Illustrations NOT shown actual size

Locate the original wiring harness that supplied power to the original heater motor (these wires were previously cut on the engine side of the firewall). Reaching thru the glove box opening pull these wires out of their grommet. Measure 4" from harness and cut both wires (see figure 15). On the OEM power supply wire attach a 1/4" insulated male spade connector. Within the OEM fuse box upgrade the factory HEATER fuse with a 20 amp fuse (**VERY IMPORTANT**).

Locate the bottom left mounting hole in the firewall that attached the original heater motor. From inside of the vehicle drill a 5/8" dia. hole for the drain tube. **TEMPLATE NOTIFICATION!** A handy drilling template is included in this manual (example shown in figure 16).

CAUTION: On the engine side of the firewall there is a brake line. Be careful not drill through the brake line. It may be necessary to carefully push this line out of the way, securing it a bit lower is usually all that is necessary (see figure 17).

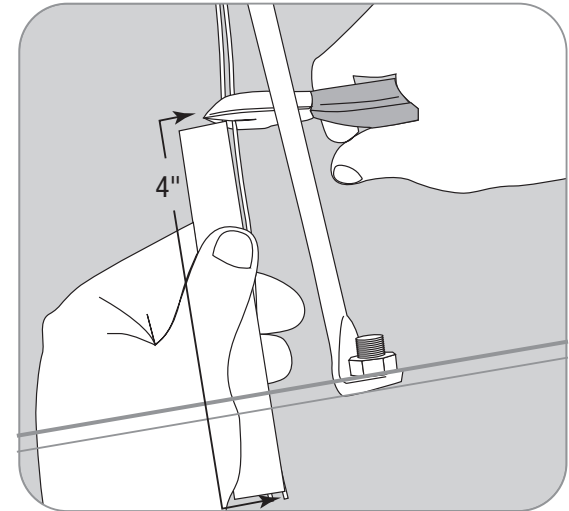

FIGURE 15

All preliminary modifications to the vehicle are complete.



YOU CAN DRILL A SMALL PILOT HOLE IN THIS LOCATION FIRST WITH A SMALLER

DRILL BIT (LIKE 3/16"), THEN PROCEED WITH THE 5/8" BIT ONCE YOU KNOW YOU HAVE CLEAR SPACE.

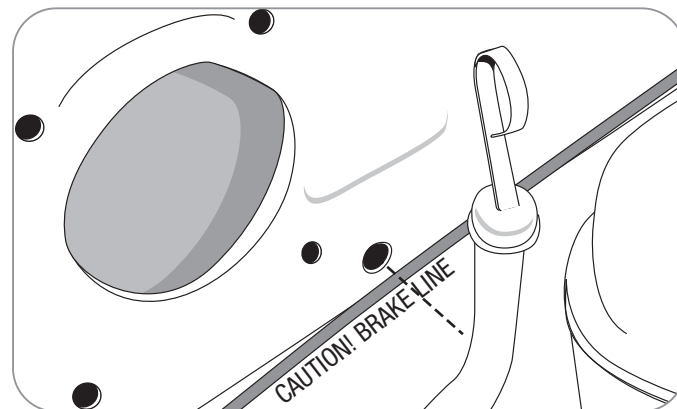

FIGURE 16

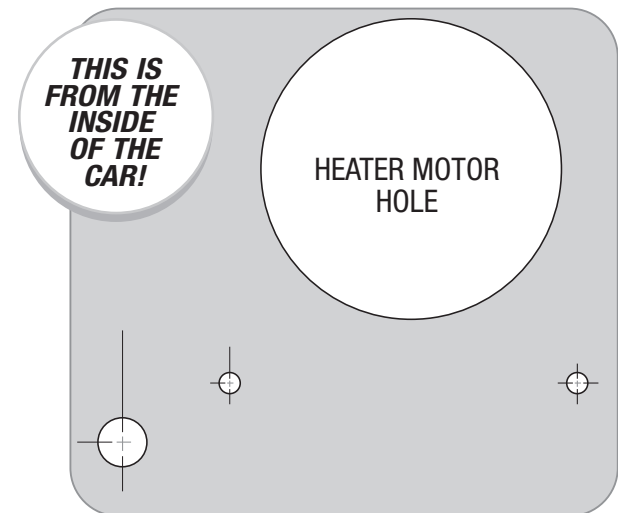

FIGURE 17

You can now begin installing your Classic Air Perfect Fit Elite System.

Locate the Fresh Air inlet block off. Install over hole in inlet cowl as shown on the passenger side (see figure 18A). Attach with three #10 - 16 x 3/4" Tek Screws. Locate the mounting tab location as shown and attach the 1/4" 20 J-clip supplied (see figure 18B).

Install a Fresh Air inlet block off over the vent opening at the drivers-side in the same way, using the four OEM nuts.

Remove evaporator unit from box and place on a flat work surface.

Locate defrost / heat duct assembly and attach to the evaporator using two #10 - 10 x 5/8" Phillips screws (see figure 19). NOTE: Be sure that the s-clips are pushed over rear flange on evaporator.

Remove ECU from main unit and set aside.

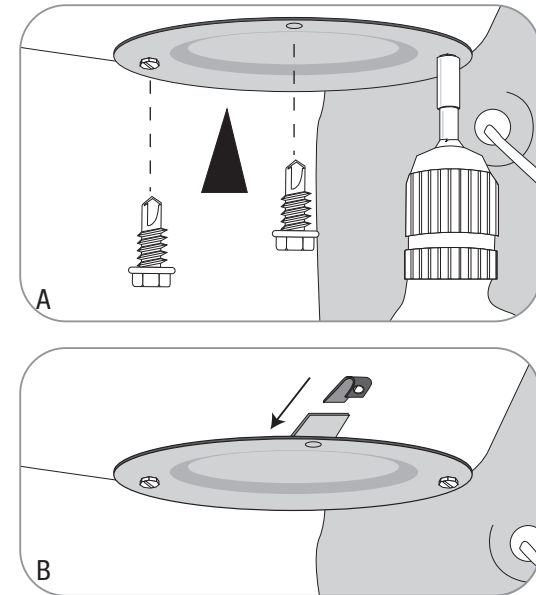

FIGURE 18

Take a minute to familiarize yourself with the evaporator unit:

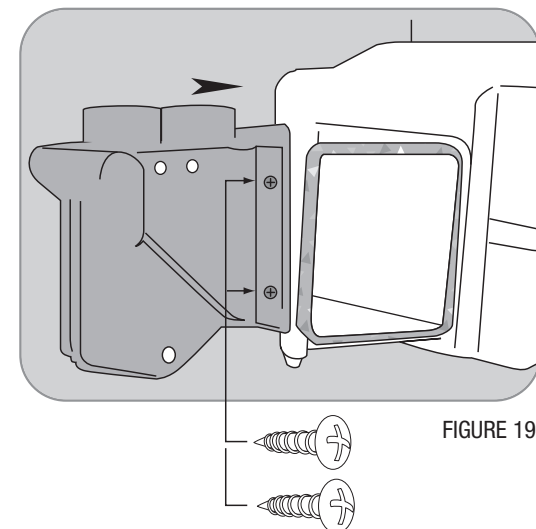
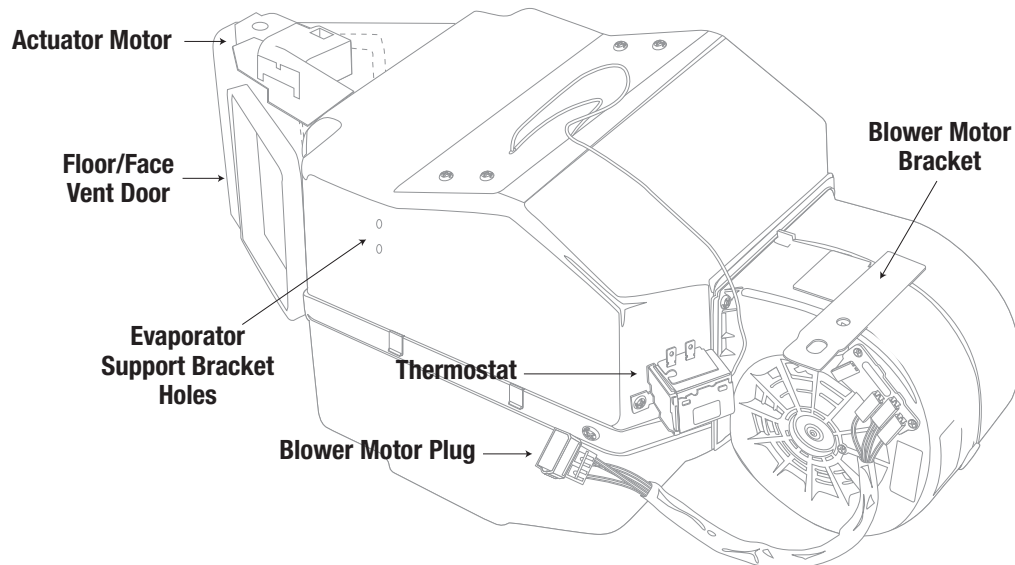

FIGURE 19

Installing the complete evaporator unit under the dash will go much easier with the help of a friend. One person can take the unit within the car and “roll” up and under the dash while the other person can be ready at the firewall area with one of the 1/4" - #20 x 5/8" bolts to secure the unit in place (see figure 20). Now the unit will be easy to level and secure. Leveling the unit is very important to insure proper drainage of condensation.

On back side of the evaporator is a mounting bracket with a 1/4"-20 J-clip. This bracket will go flush with the inside firewall and you will secure the evaporator by inserting one 1/4" - #20 x 5/8" bolt with a 1/4" washer (from the engine side) using the bottom right hole (that originally attached the original heater assembly, see figure 21).

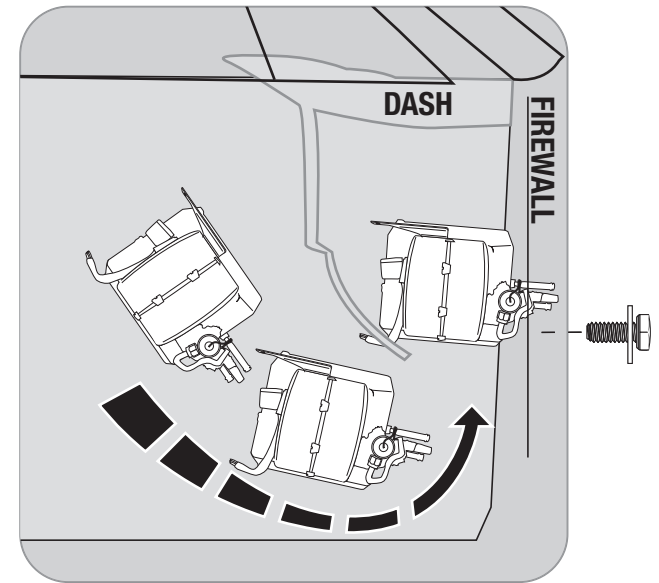

FIGURE 20

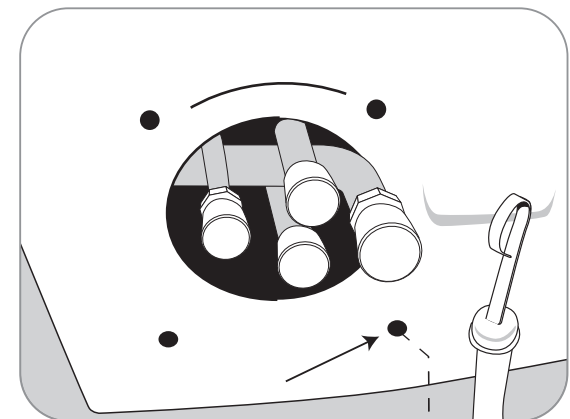
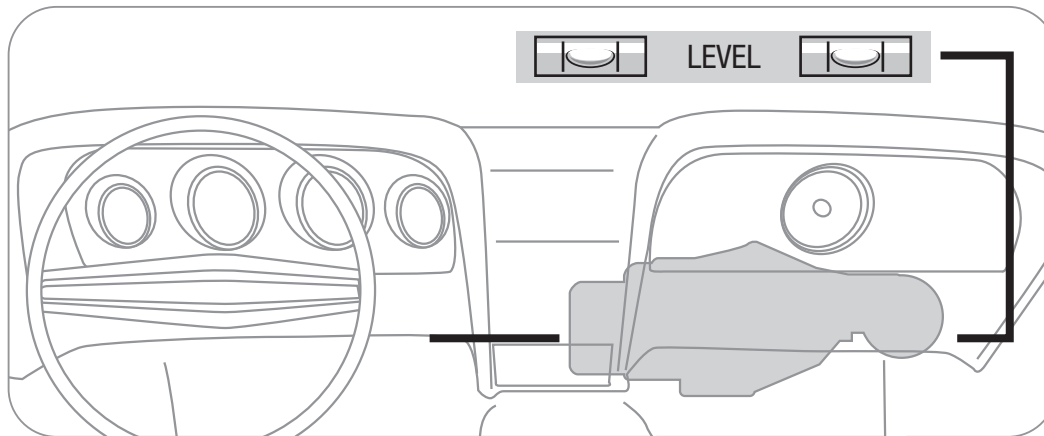
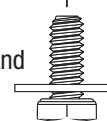

FIGURE 21

1/4 - #20 x 5/8" bolts and
a 1/4" washer



Be sure to align the evaporator unit level with the bottom of instrument panel (assuming the vehicle is sitting level) as shown above, but with a small degree of tilt toward the back to allow proper drain of condensation.

The second 1/4 - #20 x 5/8" bolt attaches the blower motor mounting bracket in the same location as the original heater mounting in front of the Air Inlet. The blower support bracket will have an additional hole behind the 1/4 - #20 x 5/8" Bolts. Install a #10 - 16 x 3/4" Tek screw through this hole and into the cowling (see figure 22).

Locate in the Hardware Sack Kit the Evaporator Mounting Bracket and attach to evaporator unit using two #10 - 10 x 5/8" Phillips screws. Attach other end to the cowling with a #10 - 16 x 3/4" Tek Screw (see figure 23). **IMPORTANT NOTE: On the side of the main unit you will see several holes for mounting holes... ONLY USE THE ONES IN THE CENTER FOR THIS BRACKET!** Do not tap into the other holes for any reason (see figure 24). Also, use a screwdriver and hand-power and do not over-tighten so you don't strip the holes.

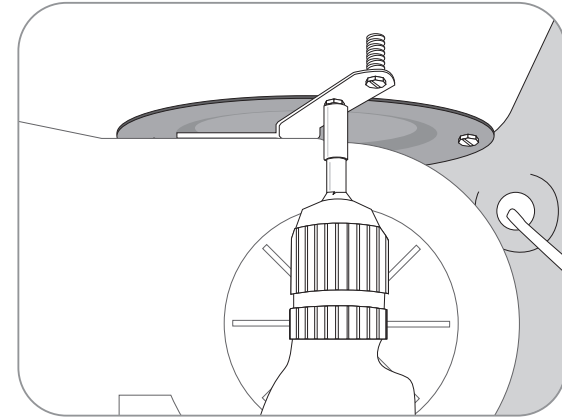

FIGURE 22

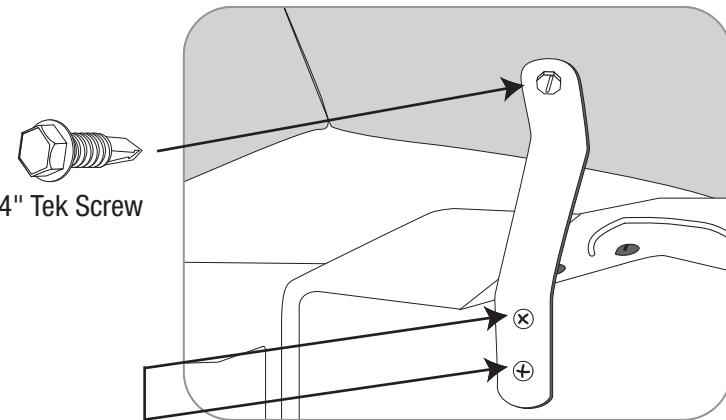

FIGURE 23

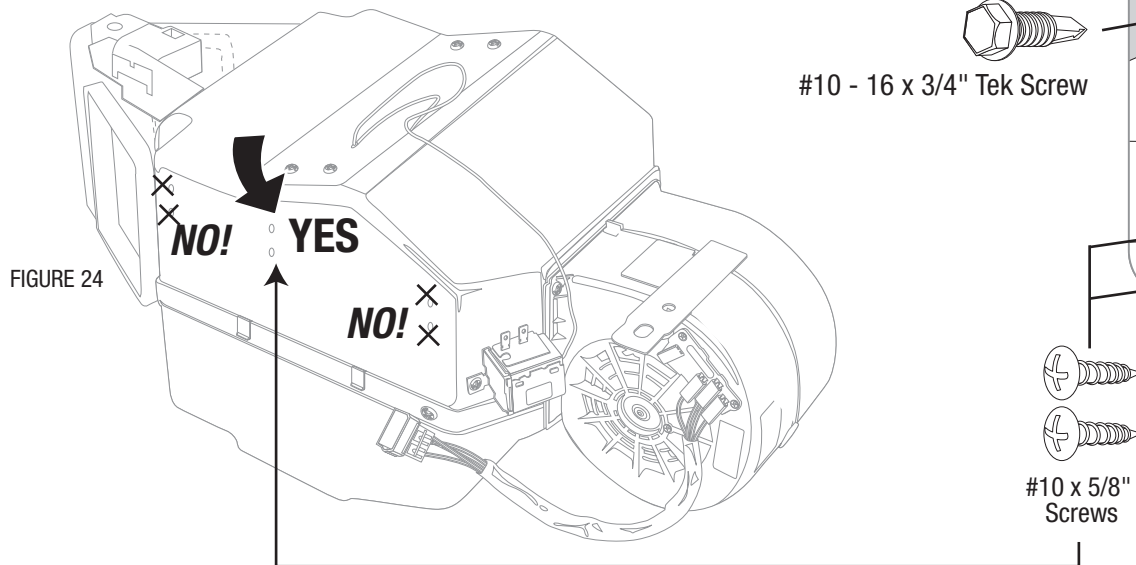
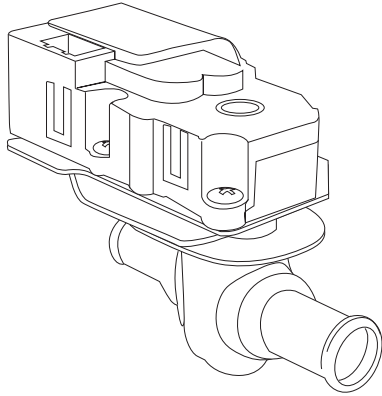

FIGURE 24

THESE ARE THE PARTS YOU WILL FIND IN BAG KIT C

You will use all of these parts and hardware during the next series of installation steps.



*Electronic Water Control Valve
PN# 16-1081-2*

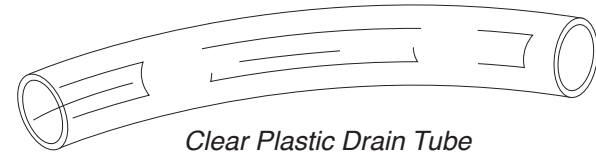

Clear Plastic Drain Tube

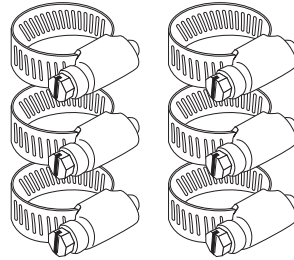

Six Worm Gear Clamps

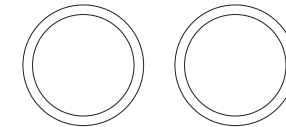

Two 1" Cap Plugs

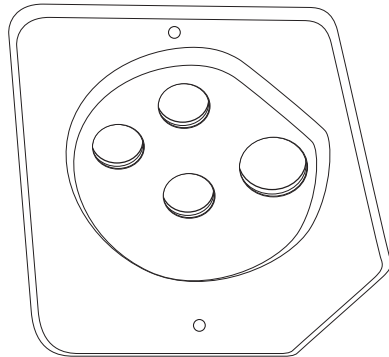

*Firewall Block Off
PN# 10-1025-1*

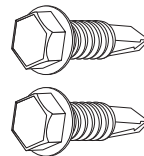

Two #10 - 16 x 3/4" Tek Screws



Refrigerant Tape

Illustrations NOT shown actual size

Water valve hose connects to this connection

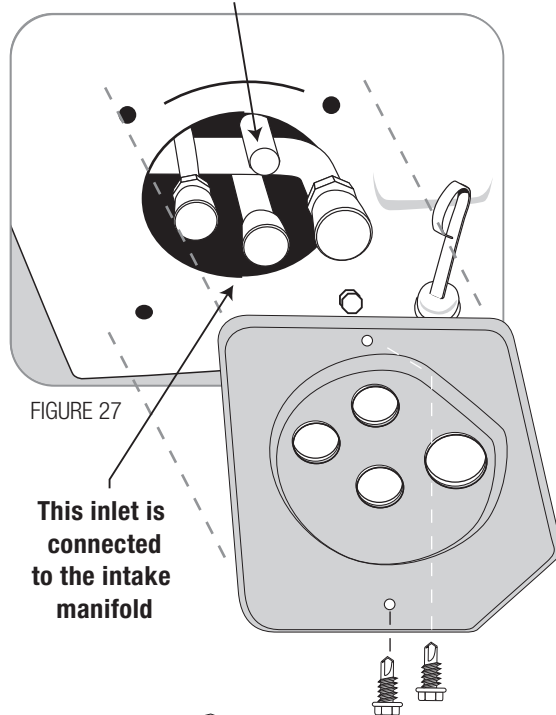
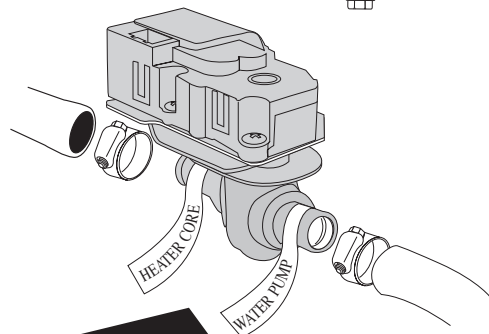

FIGURE 27

This inlet is connected to the intake manifold



FOLLOW THESE TAGS... CHECK IT TWICE BEFORE PROCEEDING!

In **Bag Kit C** you'll find the firewall block off. Install this over the hose connections coming thru the firewall within the engine compartment. Attach with six #10 - 16 x 3/4" Tek screws (see figure 27). **TIP: This would be a good time to "jump" ahead a bit, and remove the ORANGE cable from Bag Kit D and route it thru the block off plate (it will be plugged into the electronic water valve). The cable for the electronic water valve can share the hole with smaller liquid line opening.**

IMPORTANT NOTICE: PROPER INSTALLATION OF WATER VALVE INSTRUCTIONS!!!

Classic Auto Air has done extensive testing on the correct method to install the water valve in order to get a repeatable and progressive temperature control. **Your water valve MUST be installed per these instructions!... (if not, your system will not work properly... and that's an absolute fact).**

The **lower** connection on the tubes coming thru the block off assembly is going to be routed to the water outlet on the intake manifold. Attach your hose with cable clamps on both ends and route where it will not interfere with linkage or come in contact with exhaust manifolds or headers.

The **upper** port coming thru the firewall will be routed to and thru your new your electronic water valve (the water valve is marked for easy installation). First Attach a 6" piece of 5/8" dia. heater hose with the supplied worm gear clamp. Attach to the inlet side of the water valve using another supplied hose clamp. Attach a heater hose from the outlet side of the electronic water valve and route to the connection on the water pump.

Insert a 6" piece of the clear, 1/2" drain tube we included through the hole previously drilled and attach over the drain nipple. Seal around tube with refrigerant tape.



THESE ARE THE PARTS YOU WILL FIND IN BAG KIT D

You will use all of these parts and hardware during the next series of installation steps.

The ECU will be found in its own box

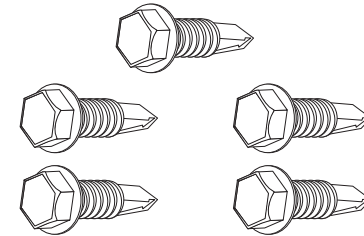
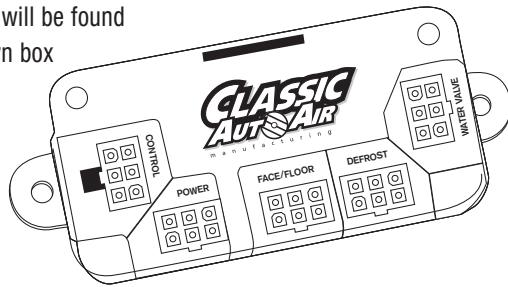

Five #10 - 16 x 3/4" Tek Screws

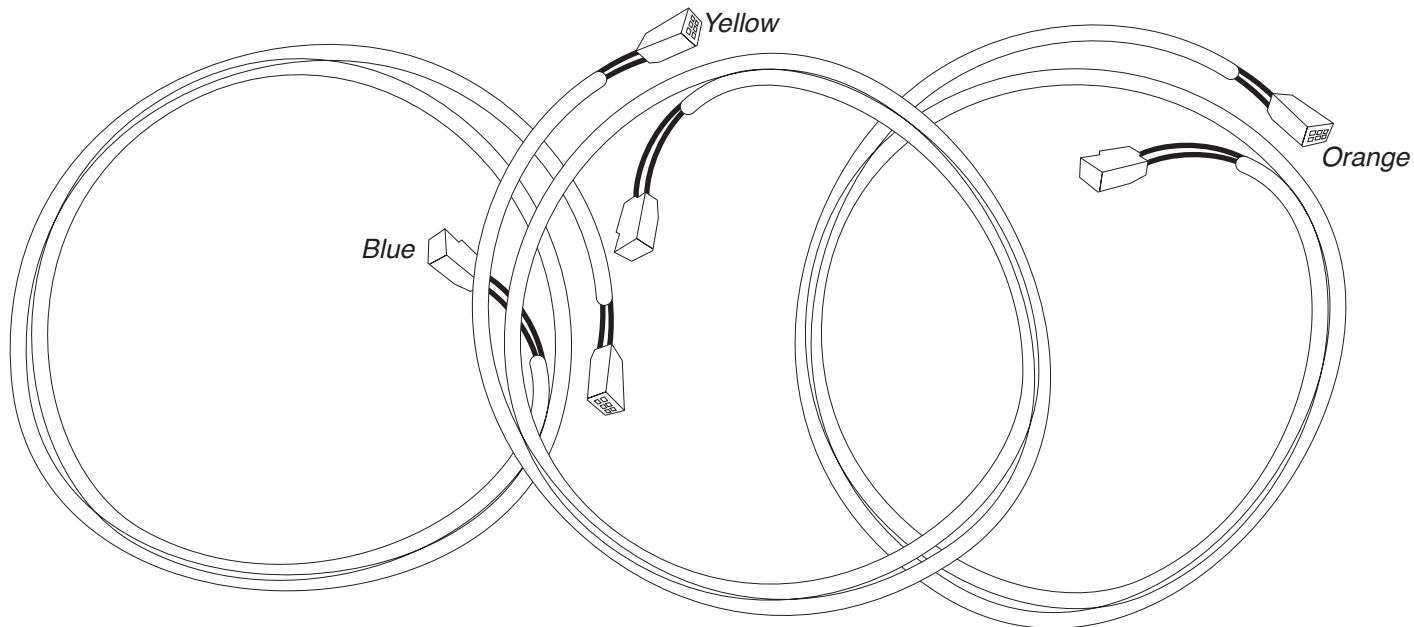

EZ Wire Harness System

Illustrations NOT shown actual size

We've included enough wire length to allow you to mount the ECU in a variety of places. It is very important that you mount this in a place where it will stay dry and that vibration is at a minimum. Also make sure that where ever you mount it does not interfere with any moving controls or cables. We recommend mounting it just above the right hand side of the main unit using the included tek-screws.

IMPORTANT! DON'T MOUNT THE ECU PERMANENTLY JUST YET. THAT CAN BE DONE AFTER YOU CALIBRATE THE UNIT (SEE NEXT PAGE).

In **Bag Kit D** you will find three wiring harnesses with connections at each end. Plug the harness with YELLOW band into the YELLOW ECU port and the other end into the servo motor on the main unit (motor is marked with YELLOW INDICATOR). Repeat this process for the other two harnesses, following the color coding indicated on cables and ports. Attach cable in the engine compartment to the electronic water valve (see figure 27). Using one of the CAP PLUGS provided, slot it and install over the heater hose/cable.

NOTE: The GREEN harness connection will be made from the harness you previously installed, just plug the loose connection in the CONTROL port on the ECU.

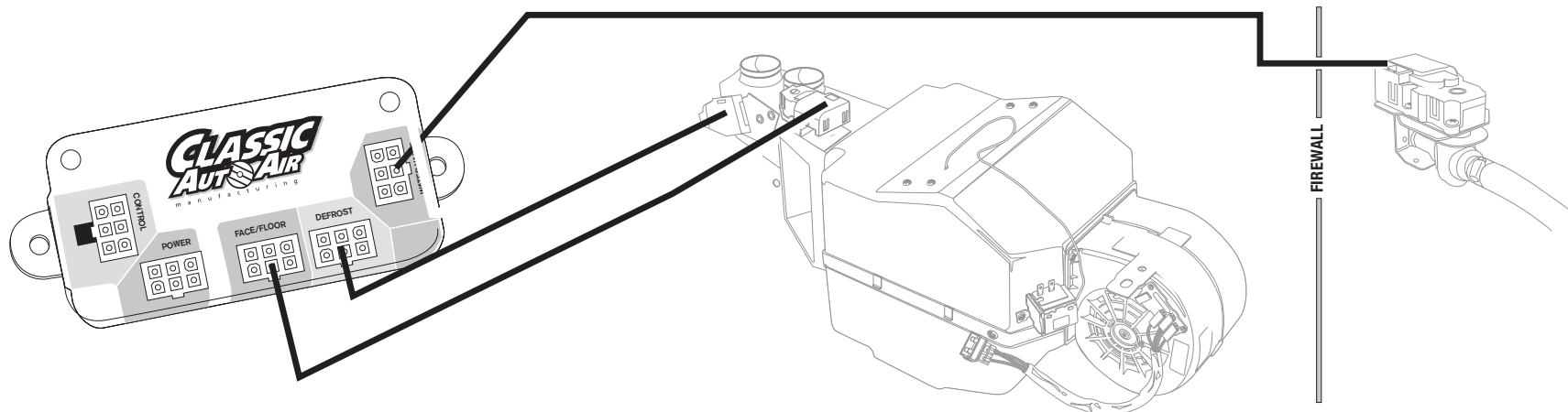
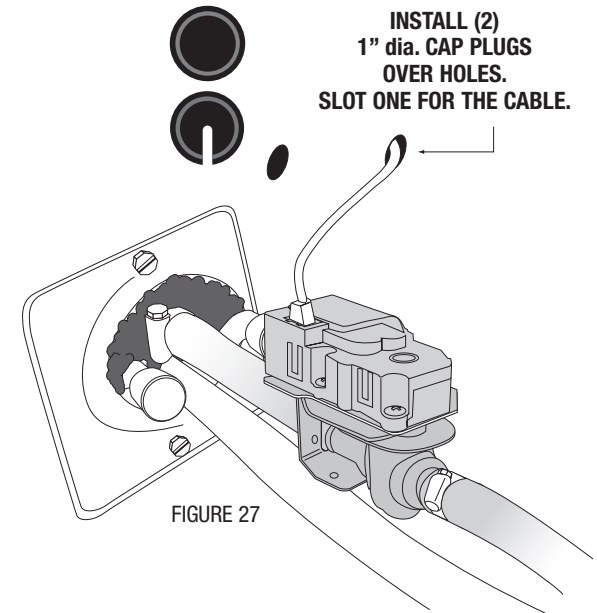

Wiring Diagram/Overview

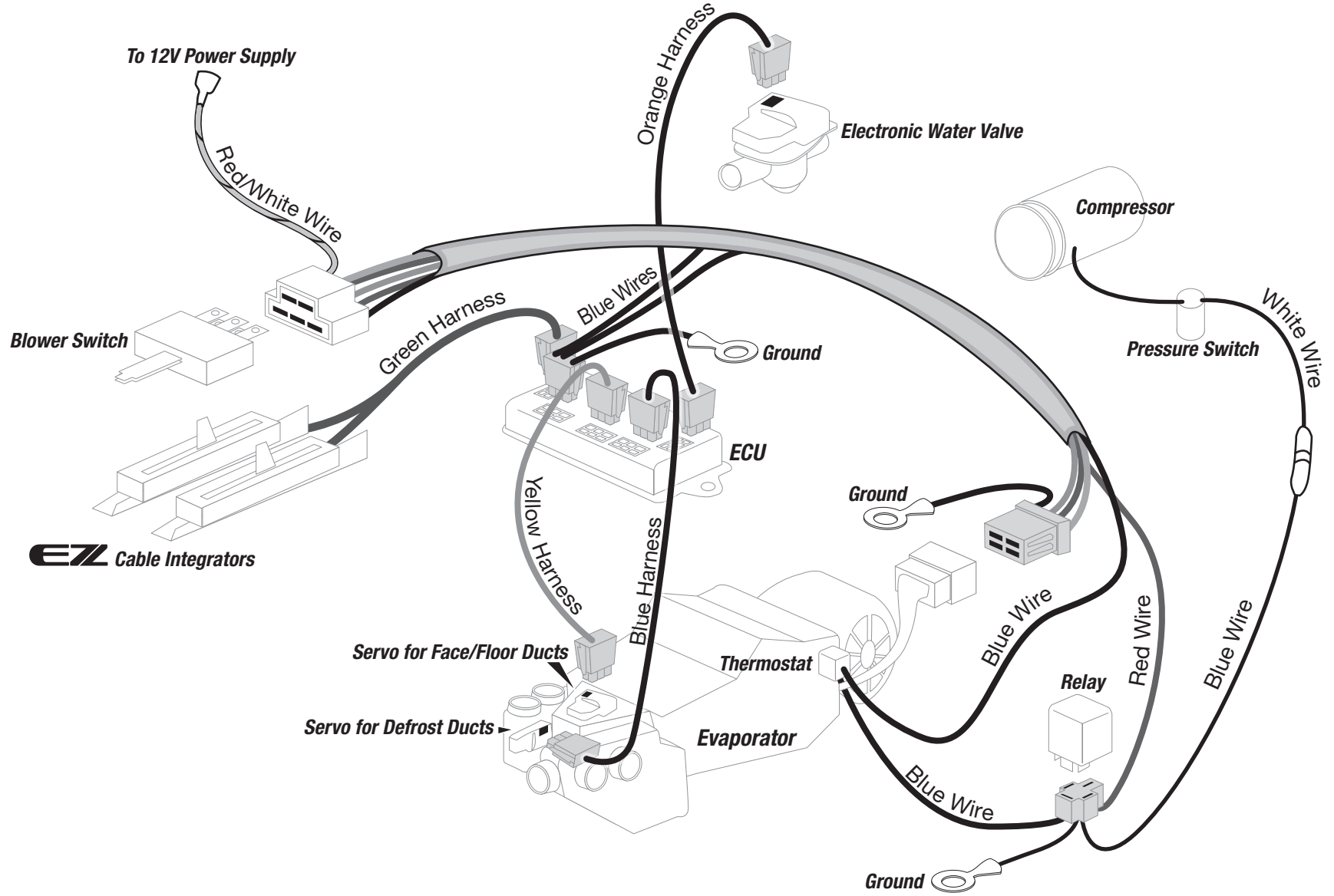

REMINDER: BE SURE THAT THE WIRING HARNESS DOES NOT INTERFERE WITH THE OPERATION OF ANY CONTROLS.



Temporarily reconnect the car battery at this time. You will need a full 12 volts to complete the calibration.

WELCOME TO EZ CALIBRATION...

Follow these directions carefully and your unit will be calibrated in just a few minutes. Before we boxed and shipped your unit, we tested and calibrated it to factory specifications to make sure it is capable of operating at maximum efficiency. However, the unit must still be calibrated to your specific vehicle and controls. This is an easy process that can be done in a few steps. If for any reason your unit does not calibrate properly the first time, just turn off the unit and rerun the setup process. **NOTE: When you move a knob to a new position, do it in ONE continuous motion.**

#1

Plug CALIBRATION KEY into ECU

#2

Position your controls like this example.

#3

Move FAN control to medium in one motion...

LED ON 1 Second Later... LED OFF

#4

Move MODE control to DASH in one motion...

LED ON 1 Second Later... LED OFF

#5

Move TEMP control to HOT in one motion...

LED ON 1 Second Later... LED OFF

#6

After 1 second the LED turns back ON

You may be able to hear the internal door(s) move back and forth...

LED ON Approx. 30 Seconds Later... LED OFF

#7

Move the FAN knob to OFF (powers off unit)

#8

REMOVE KEY AND STORE IN SAFE PLACE

That's it. Your unit is now fully calibrated. Disconnect the battery and move on to the next phase....

THESE ARE THE PARTS YOU WILL FIND IN BAG KITS E, F, and G

You will use all of these parts and hardware during the next series of installation steps.

Bag E

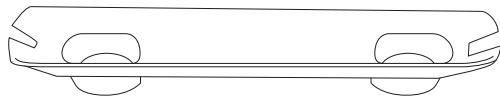

Defrost Adaptor
PN# 2-1027-3

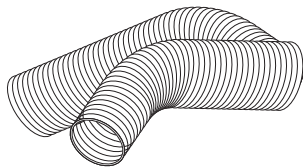

Two Duct Hoses, 2" I.D.

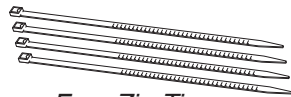

Four Zip-Ties



Four #10 - 10 x 5/8" Screws

Bag F

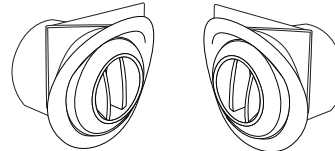

Driver & Passenger Side Louver Ball Assemblies
PN#2-1027-4

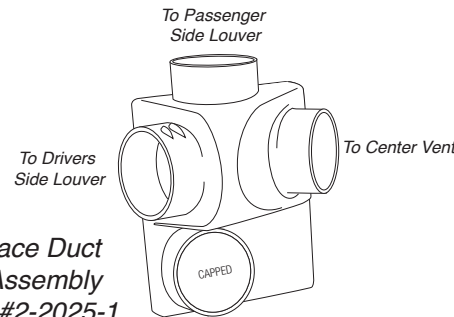

Face Duct
Assembly
PN#2-2025-1

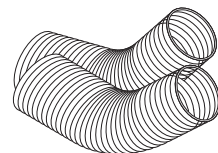

PN#
Two Duct Hoses
2" I.D.



Four Zip-Ties

Bag G

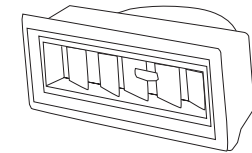

Center Dash Vent
PN# 2-1027-5

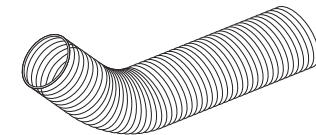

One Duct Hose, 2" I.D.



Two Zip-Ties

Illustrations NOT shown actual size

Bag Kit E. In order to use your OEM defrost diffuser, you need to modify it slightly and attach our included defrost adapter. Remove the OEM diffuser and lay on a flat surface. From the top of the duct measure and mark 4" down from the top. Cut off the lower portion and discard. Attach our adapter and secure with the screws we've included (see figure 28).

Attach flex hoses to the adapter and route to the assembly on the backside of the evaporator (see figure 29).

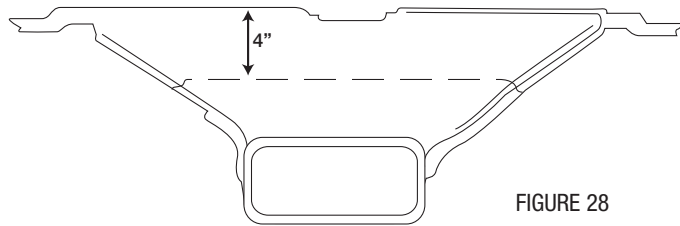
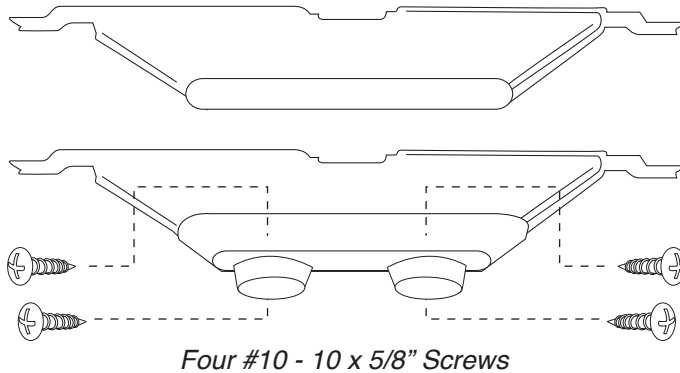

FIGURE 28



Four #10 - 10 x 5/8" Screws

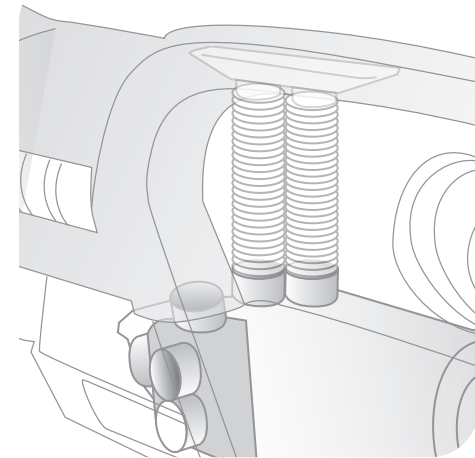

FIGURE 29

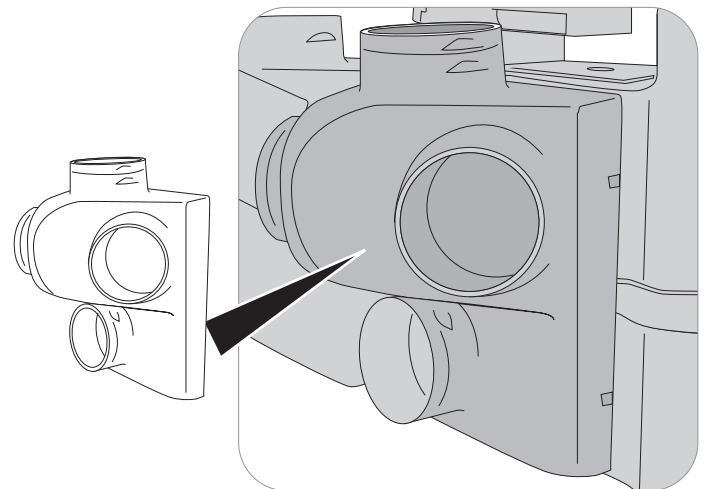

FIGURE 30

The face/floor assembly comes pre-installed with s-clips which allow you to install it onto the evaporator unit quickly and securely (see figure 30).

Bag Kit G: Installing the center louver vent requires some cutting to the dash pad. We've included a template for cutting the center louver hole. Use this template as shown below, but cut a bit smaller than the template hole and test fit/enlarge until you have a snug fit.

Center Louver: In order for your new center louver fit to fit into the dash, the dash pad must be cut where the OEM louver would have been. This will be easier if the dash pad is removed, but that is optional. Cut-out the template we've included, tape to the dash pad, and carefully cut a hole thru the pad (see figure 32). The dash is somewhat delicate, so use a very sharp instrument and cut carefully and cleanly. You will encounter a thin metal strip running thru this area of the dash. You do not have to remove this metal strip, just cut the left and right sides of it down until you can bend it inward.

Your new center vent should fit very firmly in the new hole. Slide the new louver into the dash then attach the supplied duct hose with the zip-ties on each on each hose adapter (see figure 32). Route to the face outlet on the evaporator.

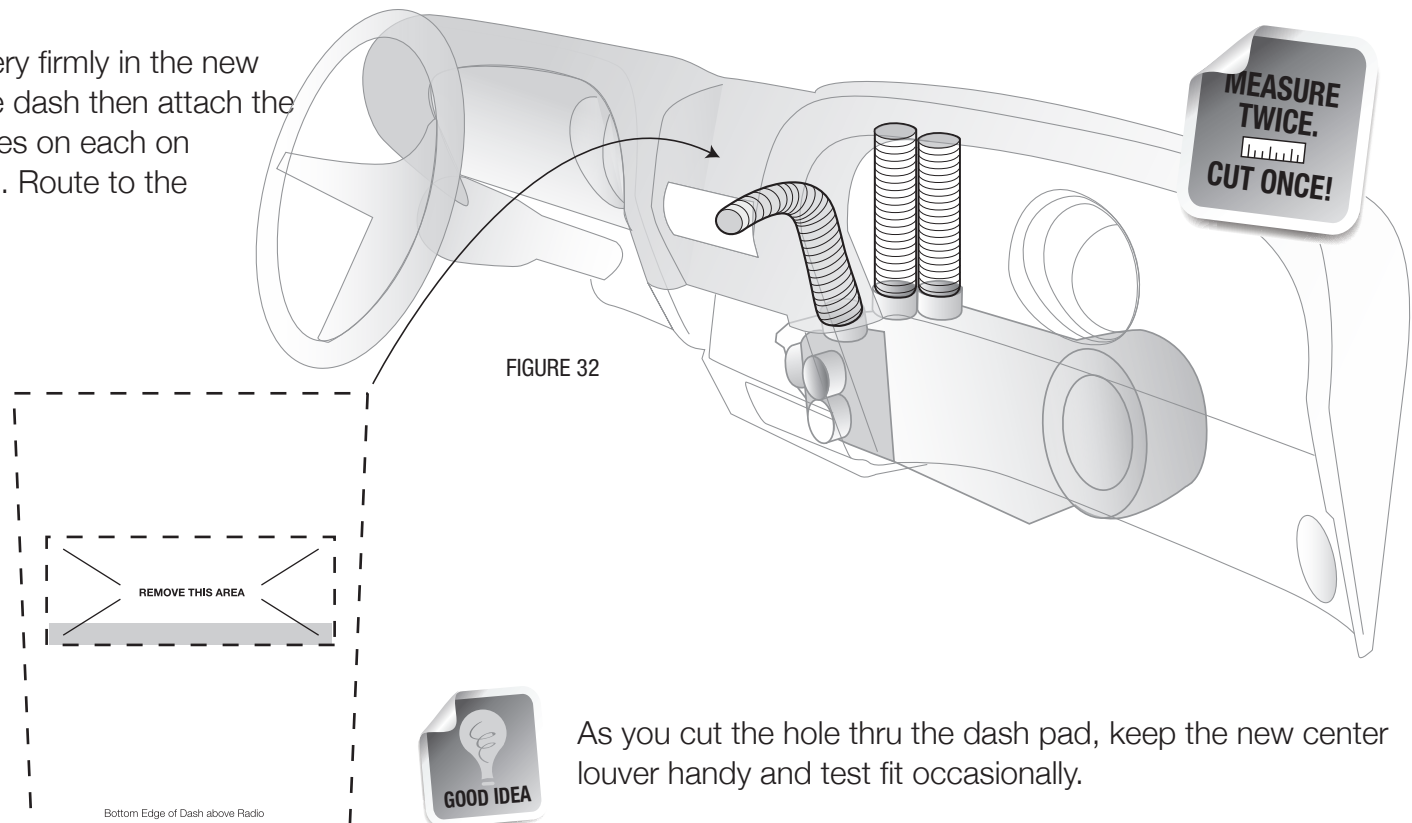

As you cut the hole thru the dash pad, keep the new center louver handy and test fit occasionally.

Bag Kit F: To install your new louver ball assemblies you'll need to drill a hole on the drivers and passenger side lower dash. We've included templates for each side. Cut these templates out, tape to dash (they will align with the curvature of the lower dash), and cut a bit smaller than the center hole. You can use a file to gradually enlarge the holes until the ball louvers fit into securely. Your new louver ball assemblies are actually three pieces, the main louver assembly, a backing plate, and screw-on adapter. Once the main assembly fits in the hole firmly, place the backing plate into place from the back of the dash, and then thread the flex hose adapter onto the main assembly. This will securely hold the louver ball assembly in place.

Once both louvers are in place, you can attach flex hoses to both (securing with zip-ties) and route to the face/floor assembly and attach as shown.

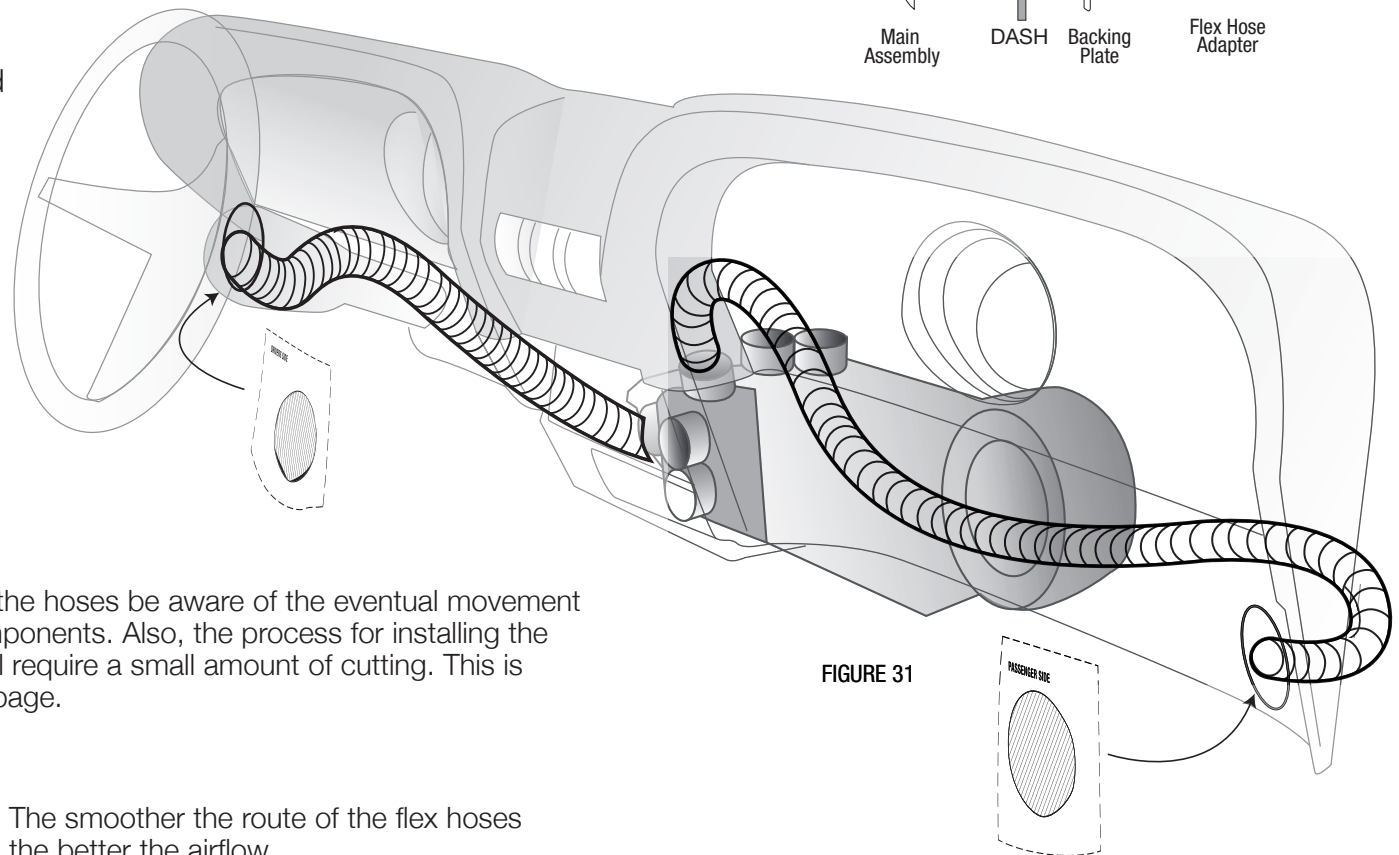
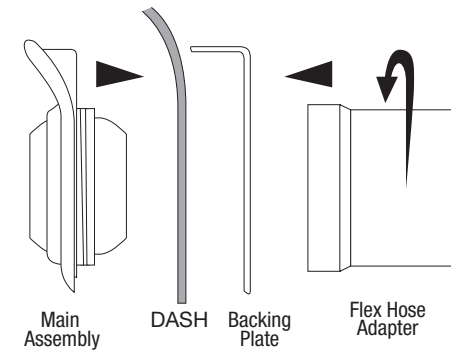

During installation of the hoses be aware of the eventual movement of the wiper arm components. Also, the process for installing the center louver vent will require a small amount of cutting. This is outlined on the next page.



The smoother the route of the flex hoses the better the airflow.

You can reinstall the glove box, radio, bezel, facia and the console at this time.

This completes the interior portion of the **PERFECT FIT-ELITE** installation process. This is a good time to make a final check that all the controls still move freely and that nothing is loose or hanging down.

The interior of your car should look pretty much the same as before you started (or better). Plus you probably got to know the underside of your dash a lot better and might even have repaired or upgraded components that needed attention.

Good Job... Let's move on to the major components within the engine compartment....

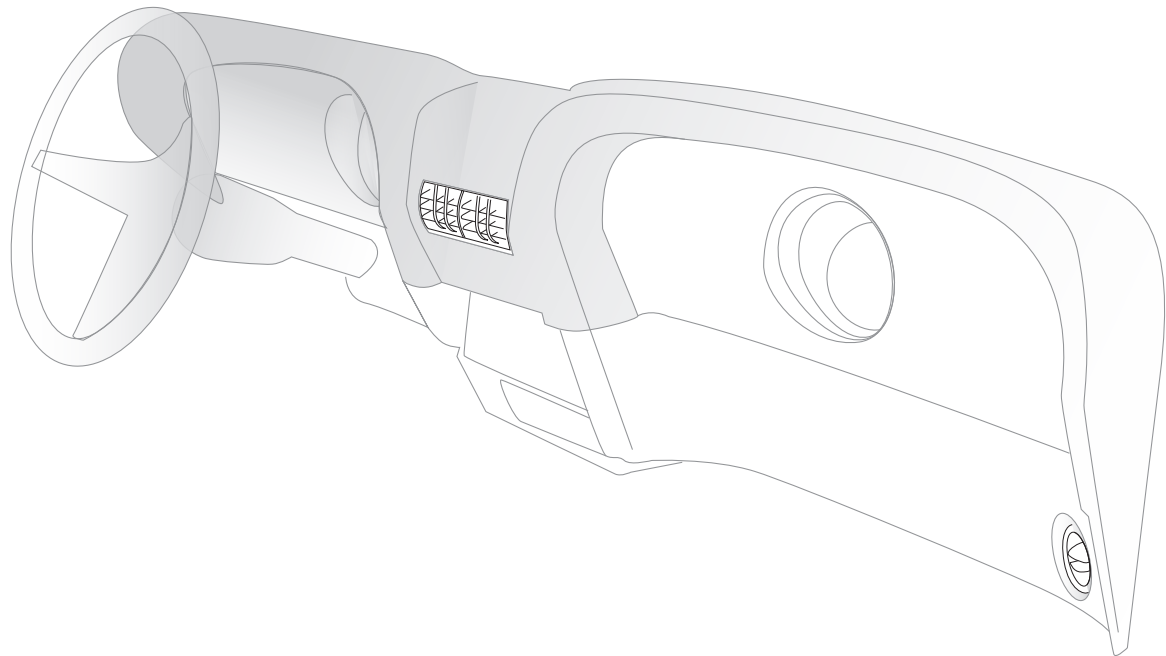

THESE ARE THE PARTS YOU WILL NEED FOR THE ENGINE COMPARTMENT INSTALLATION

You'll find all of these parts within the main box

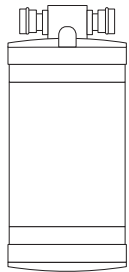

Drier

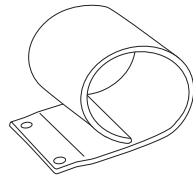

Drier Bracket

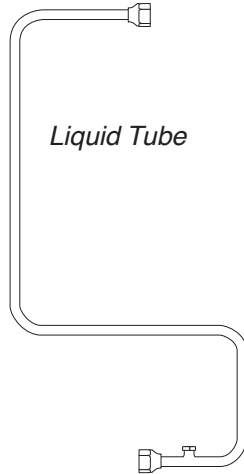

Liquid Tube



Condenser Brackets

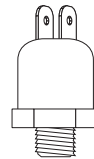

Pressure Switch

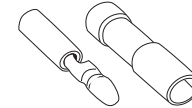

Splice and Bullet Connector

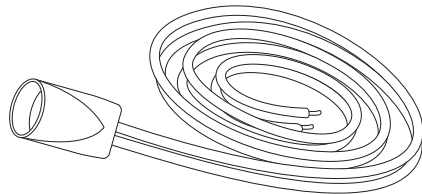

Pressure Switch Harness

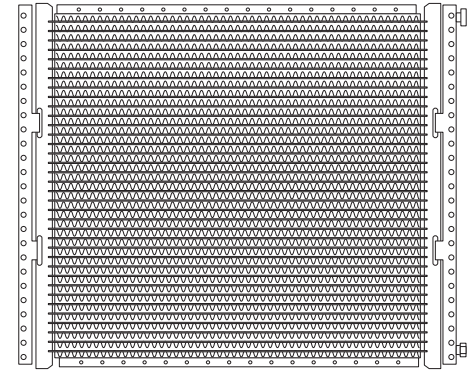

Condenser

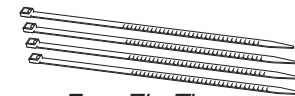

Four Zip-Ties

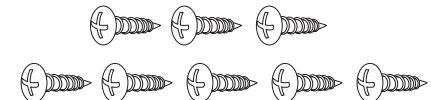

Eight #10 - 20x5/8" Screws



Two #8 - 20 x 5/8" Bolts and Lock Nuts

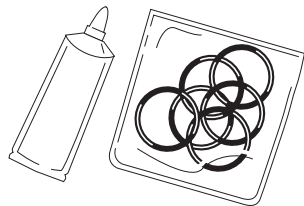

Bag of O-rings and Mineral Oil Tube

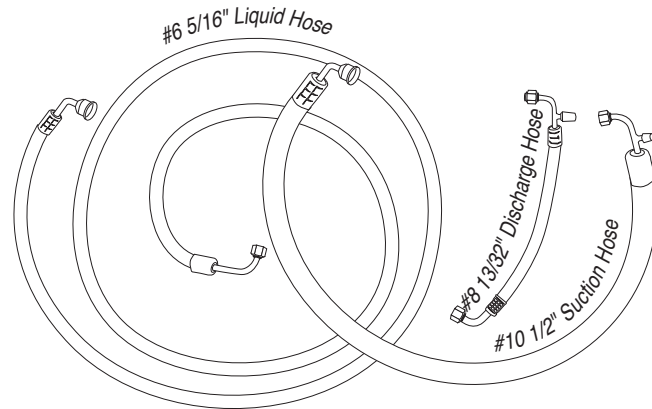

Three Refrigerant Hoses



ENGINE COMPARTMENT INSTRUCTIONS

**STEP ONE: IF YOU HAVE NOT DONE SO ALREADY,
DISCONNECT THE BATTERY.**

STEP TWO: During the next steps you'll be installing the condenser, drier, and routing the pressure switch wire and the A/C line(s). Since much of this is installed in the OEM location for the condenser, you'll need to remove the center grill section, horn(s), and latch support assembly (see figure 33). Be sure to retain all the mounting screws – you'll reinstall these pieces in the exact reverse order with the OEM screws.

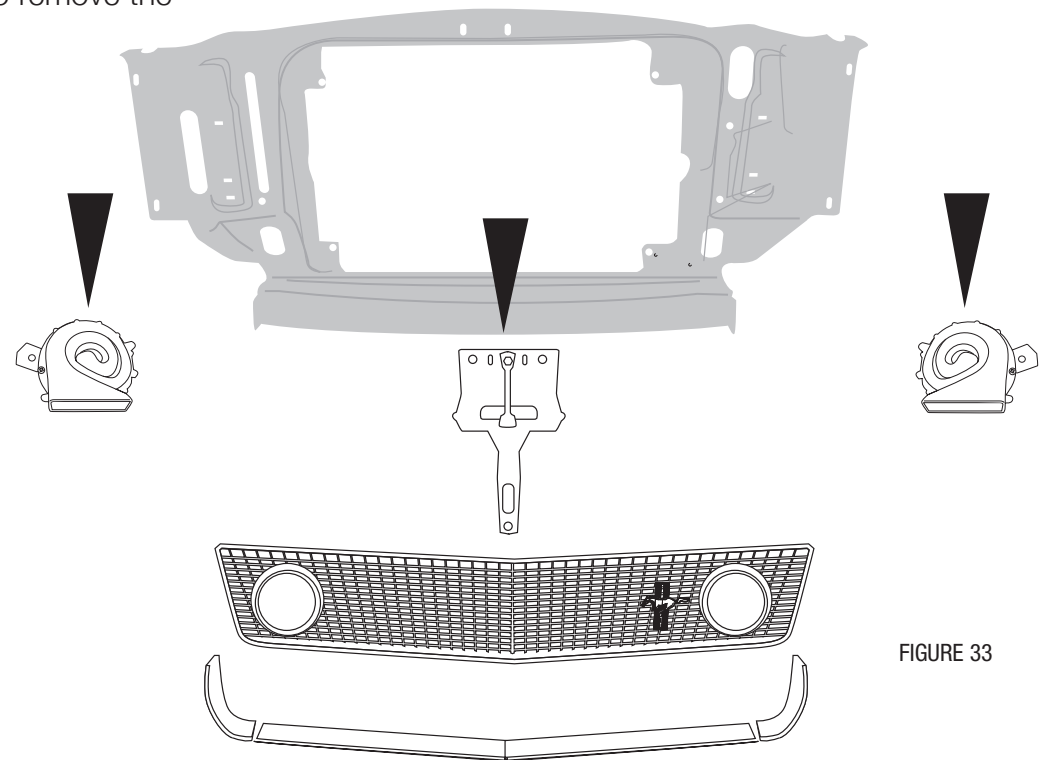

FIGURE 33

STEP THREE: DRIER AND CONDENSER PREPARATION. You can perform most of the following steps on a clean flat surface like a workbench. Lay the condenser down so that both hose connections are on the right side (the larger connection will be on top). The drier is conveniently mounted on the right hand side of the condenser. First insert the drier into the drier mounting bracket (it's basically a sleeve for the drier). Attach the drier liquid tube to the drier and also to the connection on the condenser (tighten connections at either end using supplied o-rings on both ends and a few drops of mineral oil to each o-ring). With these two components combined it will be easy to find the correct place to attach the drier bracket to the condenser with the included #8-20 x 5/8" bolts and lock nuts (attach drier and bracket from the back of the condenser).

STEP FOUR: Screw the high-pressure switch into the port at the lower end of the drier liquid tube. Go ahead and plug the pressure switch harness into the switch at this time (black electrical boot with two long white wires).

STEP FIVE: Install the upper condenser bracket (A) using four #10 - 20 x 5/8" screws in the 4th, 5th, 8th and 9th holes on the condenser from the left, be sure the bend on the brackets are facing out towards you, (**top bracket mounts from the front of the condenser, bottom bracket from the back**). Next, attach the lower bracket (B) using four #10-20 x 5/8" screws in the 5th, 6th, 9th and 10th hole from the left hand side. This bracket has a large hole that corresponds to the OEM latch support previously removed from the vehicle.



Reminder...
Use two
wrenches to
tighten o-ring
fittings

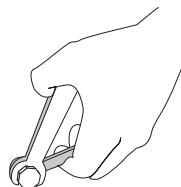

You can easily find the correct position for mounting the drier to the condenser by using the drier liquid tube as a gauge.

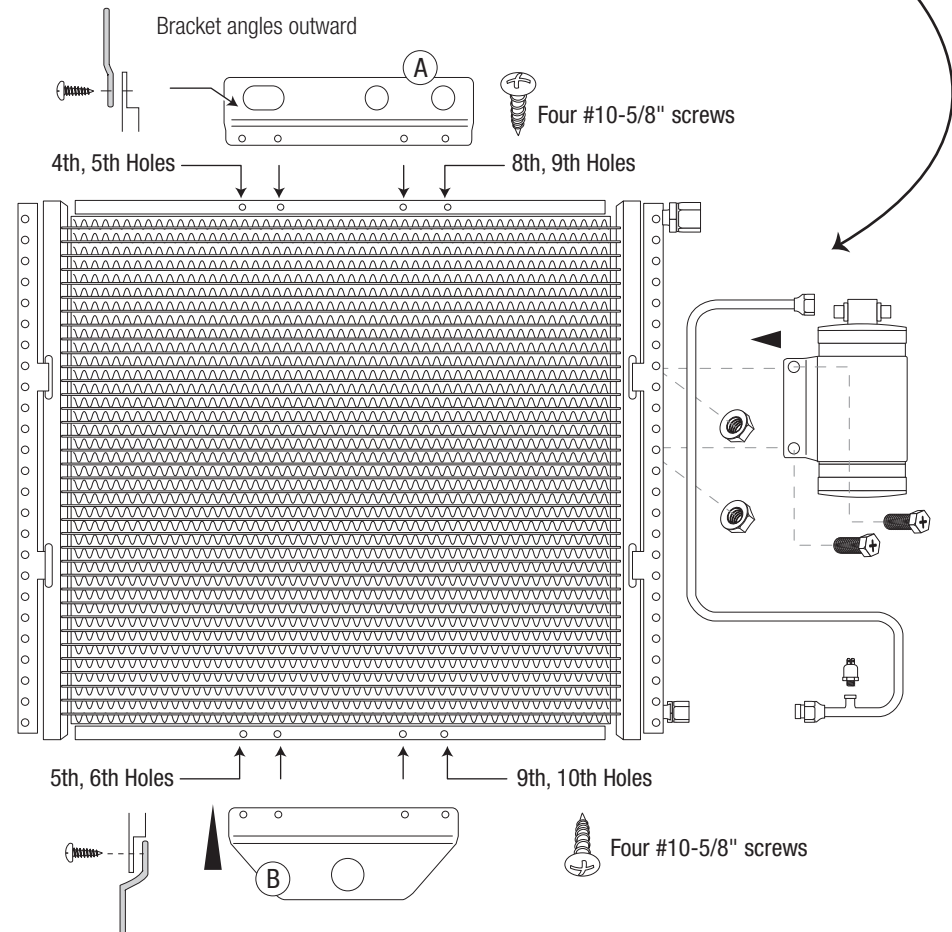

STEP SIX: Your OEM radiator support was designed to support a A/C condenser and conveniently has two small indentations on the drivers side core support (see figure 38, aftermarket core supports may or may not have these indentations). Locate these two small indentations and drill a 1 3/8" hole thru each (be sure to check for any obstructions before drilling, and remove any sharp burrs from the drilling before continuing, see figure 34), then the area between the two holes will be easy to remove (example figure 35). You'll route the discharge hose to the compressor will go thru this hole, as well as the liquid hose and the wiring harness plug for the high-pressure switch.

STEP SEVEN: Place the condenser/drier unit into place, locating it so that the holes in the condenser brackets align with the holes in the core support used to attach the hood latch (it will rest on the lower radiator core brace, see figure 36).



If you want to verify that you have the correct indentations in sight before drilling, place fit the condenser into it's final location. Also, the holes on the upper bracket are larger than needed to allow for small adjustments. The condenser is held in place when the hood latch is reinstalled at a later time.

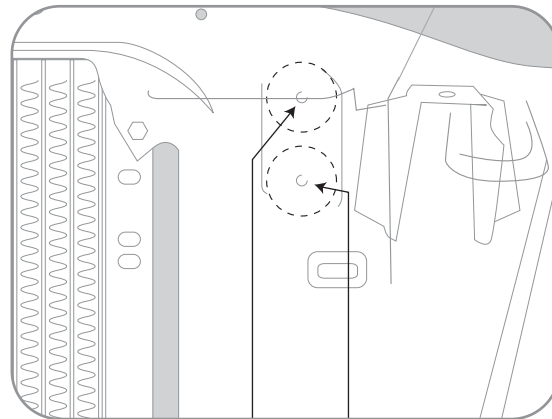

Drill two 1 3/8" holes

FIGURE 35

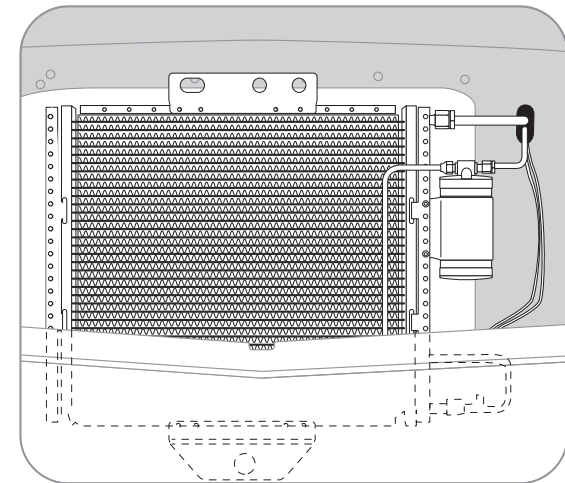
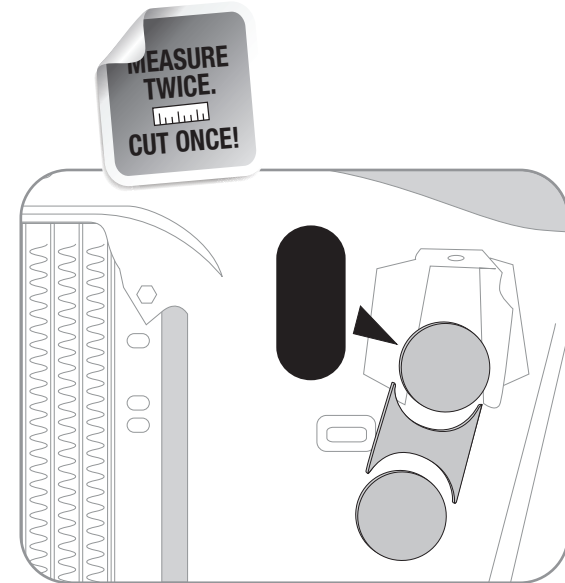

STEP EIGHT: Time to install the compressor kit. Included in your box is a premium compressor kit with all the parts you'll need to install the compressor. This kit includes instructions specifically written for your engine. Once you've installed the complete compressor kit, continue on to connecting the hoses.

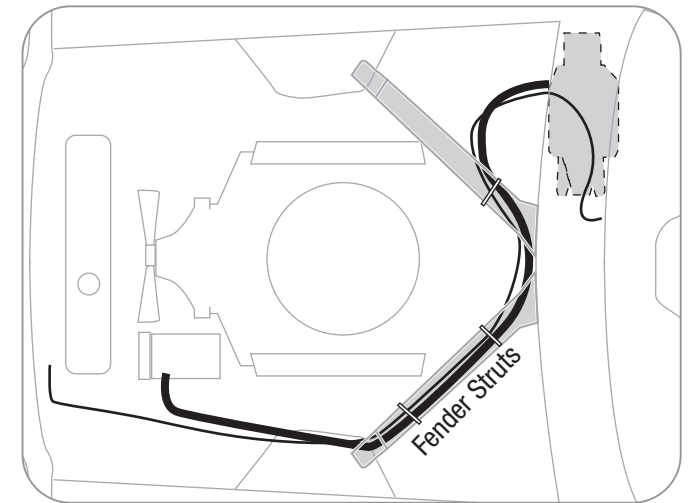
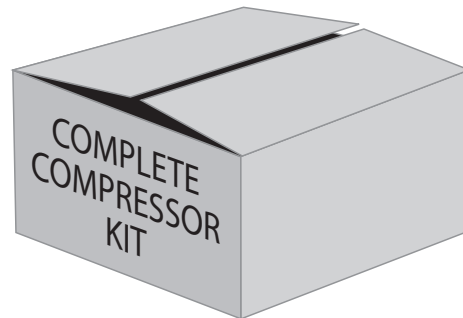

FIGURE 37

STEP NINE: CONNECTING THE HOSES:

- 1) Attach the #8 Discharge Hose (13/32") to the upper connection of the condenser and route thru the hole previously drilled in the core support and route to the compressor. Tighten fittings using o-rings and mineral oil provided.

- 2) Attach the #6 liquid hose (5/16") to the drier and route thru the remaining hole previously drilled into the core support and along the underside of the fender struts, around the engine, and to the connection at the firewall on the evaporator unit (see figure 41). Using supplied zip-ties you'll attach this hose, the suction hose and the lead from the high pressure switch to the strut braces, securing all three at once. Tighten fittings using o-rings and mineral oil supplied in kit.

- 3) Attach the #10 suction hose (1/2") to the compressor and route as mentioned above. Tighten fittings using o-rings and mineral oil supplied in the kit.



FINAL STEPS: Take a look around at your installation and check all fittings and bolts for tightness, check the heater hose clamps for tightness, and make sure nothing is routed in a way to obstruct any moving parts. **You can refill the radiator and reconnect the battery at this time.**

WAY TO GO! You've just completed the installation of your new A/C system. The very final step is to fully charge and test your new system.

On the next page you'll find specifications for proper final preparation for your A/C technician.



New A/C System Preparation... A MUST READ!

Please read thru these procedures before completing this new A/C system charging operation.

A licensed A/C technician should be utilized for these procedures to insure that your new system will perform at it's peak, and that your compressor will not be damaged.

- 1) Your radiator/cooling system is an integral part of your new system. Please insure that you have a 50/50 mix of distilled water and antifreeze. The heater coil **MUST** be purged (cycle heater control valve) to make sure no water, without antifreeze, is in the heater coil before you charge the A/C system.
- 2) Evacuate the system for 45 minutes (minimum).
- 3) **Your new compressor MUST be hand-turned 15-20 revolutions before and after charging with liquid. Failure to do this may cause the reed valves to become damaged** (this damage is NOT covered by your warranty).
- 4) Your new system requires 134a refrigerant. It will require 1.5 lbs (or 24 oz).
- 5) Your new compressor comes charged with oil - NO additional oil is needed.
- 6) Insure that the new belt is tight.
- 7) **DO NOT CHARGE SYSTEM WITH LIQUID WHILE THE ENGINE IS RUNNING!**

RECOMMENDED TEST CONDITIONS: (After system has been fully charged and tested for basic operation)

- Determine the temperature outside of the car
- Connect gauges or service equipment to high/low charging ports
- Place blower fan switch on medium
- Close all doors and windows on vehicle
- Place shop fan directly in front of condenser
- Run engine idle up to approx. 1500 rpm

ACCEPTABLE OPERATING PRESSURE RANGES:

1. HIGH-SIDE PRESSURES (150-250 PSI)
2. LOW-SIDE PRESSURES (15-25 PSI in a steady state)

Readings above are based on an ambient temperature of 90° with an adequate airflow on condenser

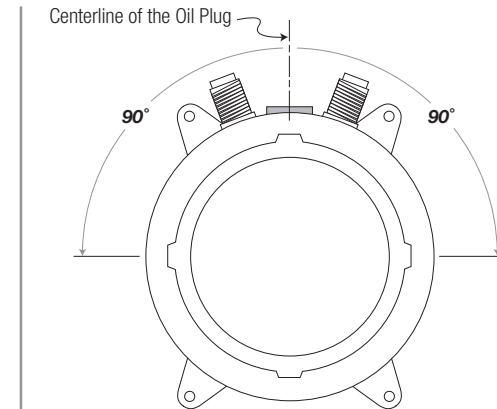

CAUTION! When mounting your compressor and/or adjusting the belt, use caution not to tilt the compressor up to or more than 90° off the centerline of the oil fill plug. This can cause compressor failure.

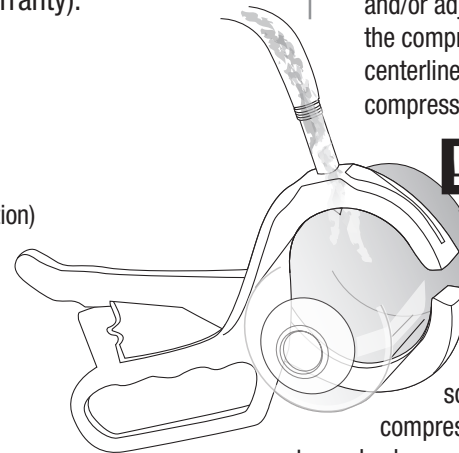

Do NOT tilt, shake or turn refrigerant can upside-down OR use a charging station to install refrigerant while the engine is running. Doing

so will direct liquid refrigerant into the compressor piston chamber, causing damage to reed valves and/or pistons and/or other components, as well as potentially seizing the compressor. Allow a minimum of 30 minutes for liquid to "boil off." You must hand turn the compressor hub (not the pulley) a minimum of 15 complete revolutions prior to starting the engine with the clutch engaged.



TROUBLESHOOTING GUIDE

TEST CONDITIONS USED TO DETERMINE SYSTEM OPERATION

(THESE TEST CONDITIONS WILL SIMULATE THE AFFECT OF DRIVING THE VEHICLE AND GIVE THE TECHNICIAN THE THREE CRITICAL READINGS THAT THEY WILL NEED TO DIAGNOSE ANY POTENTIAL PROBLEMS).

- B. CONNECT GAUGES OR SERVICE EQUIPMENT TO HIGH/LOW CHARGING PORTS.
- C. PLACE BLOWER FAN SWITCH ON MEDIUM.
- D. CLOSE ALL DOORS AND WINDOWS ON VEHICLE.
- E. PLACE SHOP FAN IN FRONT OF CONDENSER.
- F. RUN ENGINE IDLE UP TO 1500 RPM.

ACCEPTABLE OPERATING PRESSURE RANGES (R134A TYPE)

1. HIGH-SIDE PRESSURES (150-250 PSI) **Note- general rule of thumb is two times the ambient (daytime) temperature, plus 15-20%.*
2. LOW-SIDE PRESSURES (15-25 PSI in a steady state).

CHARGE AS FOLLOWS: R134A = 24 OZ.

NO ADDITIONAL OIL IS NECESSARY IN OUR NEW COMPRESSORS.

TYPICAL PROBLEMS ENCOUNTERED IN CHARGING SYSTEMS

NOISY COMPRESSOR. A noisy compressor is generally caused by charging a compressor with liquid or overcharging

- A. If the system is overcharged both gauges will read abnormally high readings. This is causing a feedback pressure on the compressor causing it to rattle or shake from the increased cylinder head pressures. System must be evacuated and re-charged to exact weight specifications.
- B. **Heater control valve installation** - Installing the heater control valve in the incorrect hose. Usually when this occurs the system will cool at idle then start to warm up when raising the RPM's of the motor. **THE HEATER CONTROL IS A DIRECTIONAL VALVE; MAKE SURE THE WATER FLOW IS WITH THE DIRECTION OF THE ARROW.** As the engine heats up that water transfers the heat to the coil, thus overpowering the a/c coil. A leaking or faulty valve will

have a more pronounced affect on the unit's cooling ability. Installing the valve improperly (such as having the flow reversed) will also allow water to flow through, thus inhibiting cooling. Check for heat transfer by disconnecting hoses from the system completely. By running down the road with the hoses looped backed through the motor, you eliminate the possibility of heat transfer to the unit.

- C. **Evaporator freezing** - Freezing can occur both externally and internally on an evaporator core. External freeze up occurs when the coil cannot effectively displace the condensation on the outside fins and the water forms ice (the evaporator core resembles a block of solid ice), it restricts the flow of air that can pass through it, which gives the illusion of the air not functioning. The common cause of external freezing is the setting of the thermostat and the presence of high humidity in the passenger compartment. All door and window seals should be checked in the event of constant freeze-up. A thermostat is provided with all units to control the cycling of the compressor.
- D. **Internal freeze up** occurs when there is too much moisture inside the system. The symptoms of internal freeze up often surface after extended highway driving. The volume of air stays constant, but the temperature of the air gradually rises. When this freezing occurs the low side pressure will drop, eventually going into a vacuum. At this point, the system should be checked by a professional who will evacuate the system and the drier will have to be changed.
- E. **Inadequate airflow to condenser** - The condenser works best in front of the radiator with a large supply of fresh air. Abnormally high pressures will result from improper airflow. Check the airflow requirements by placing a large capacity fan in front of the condenser and running cool water over the surface. If the pressures drop significantly, this will indicate the need for better airflow.
- F. **Incorrect or inadequate condenser capacity** - Incorrect condenser capacity will cause abnormally high head pressures. A quick test that can be performed is to run cool water over the condenser while the system is operating, if the pressures decrease significantly, it is likely a airflow or capacity problem.
- G. **Expansion valve failure** - An expansion valve failure is generally caused by dirt or debris entering the system during assembly. If an expansion valve fails it will be indicated by abnormal gauge readings. A valve that is blocked will be indicated by high side that is unusually high, while the low side will be unusually low or may even go into a vacuum. A valve that is stuck open will be indicated by both the high and low pressures rising to unusually high readings, seeming to move toward equal readings on the gauges.
- H. **Restrictions in system** - A restriction in the cooling system will cause abnormal readings on the gauges. A high-side restriction (between the compressor and the drier inlet) will be indicated by the discharge gauges reading excessively high. These simple tests can be performed by a local shop and can help determine the extent of the systems problem.



Trouble Shooting Your Classic Auto Air A/C System

PROBLEM: system is not cooling properly
ISSUE: cold at idle, warmer when raising engine RPM's

Make sure the Water Valve is positioned correctly

The water valve is a directional valve and should be installed with the arrow pointing towards the water pump, it should be connected to the heater hose that runs from the heater core to the water pump. If the water valve is connected to the incorrect hose it allows water to circulate through the system via the heater core over powering the cooling effect of the A/C coil, (normally the air conditioning is functioning properly).

Step 1: Check placement of the water valve, correct if needed. (In some cases changing the location of the water valve may not fix the above problem.) Continue to next step.

Step 2 If changing the location of the water valve does not rectify the issue, then possibly the water valve is permanently damaged and may need to be replaced. To check the integrity of the water valve completely remove the water hoses for the heater core and "loop" together. (This will remove the heater system completely from the possibilities) If the system now cools, replace the water valve

Verify Adequate Air Flow to Condenser

For an air conditioning system to function properly there has to be adequate airflow across the condenser. The function of the condenser is to dissipate heat, without proper airflow your system will not cool correctly in the cabin of your vehicle.

Step 1: connect gauges to a/c hoses. The pressures should be: with the ambient temp is 90, low side pressures should be between 8-25 psi, high side pressures should be between 160-260psi

Step 2: IF the low side pressures are normal and the high side pressures are high then there might be an airflow issue, continue to next step.

To test air flow to Condenser do the following three tests:

1. Place a piece of paper on the condenser with the car in idle and see if paper is held in place.
2. With car in idle, attach gages, and place a large capacity fan in front of the condenser. What happens to the pressures?
3. With car still in idle and gages attached, pour water down the front of the condenser. What happens to the pressures?

If the paper is held in place you are at least getting some air flow. If the high side decreases during test 2 & 3 then your condenser is not getting enough air which is causing your system to not cool properly. To correct this issue you will need a more powerful mechanical fan.

Step 3: Confirm correct Refrigerant charge in System

All of our systems should be charged with 24oz or 1.8lbs of R134 Refrigerant only. If overcharged you will need to evacuate the system and recharge with the correct amount.*

What measurements mean:

Low Temp and High Pressure seem to be equal...

You have a malfunctioning expansion valve that is stuck open.

High Side is extremely high and Low Side is extremely low (possibly into vacuum)...

There is a blockage in the system. Remove hoses and blow compressed air through in both directions. If pressures don't change its possible that your expansion valve is stuck closed and would have to be replaced.

***Compressor Concerns:**

This is often misdiagnosed as a problem for the system not cooling properly. If you have a noisy compressor it is due to improper charging of refrigerant. An overcharged (more than 24oz or 1.8lbs R134) compressor can cause rattling. If charged with pure liquid there is a high probability you have bent reed valves that are causing tapping sound.



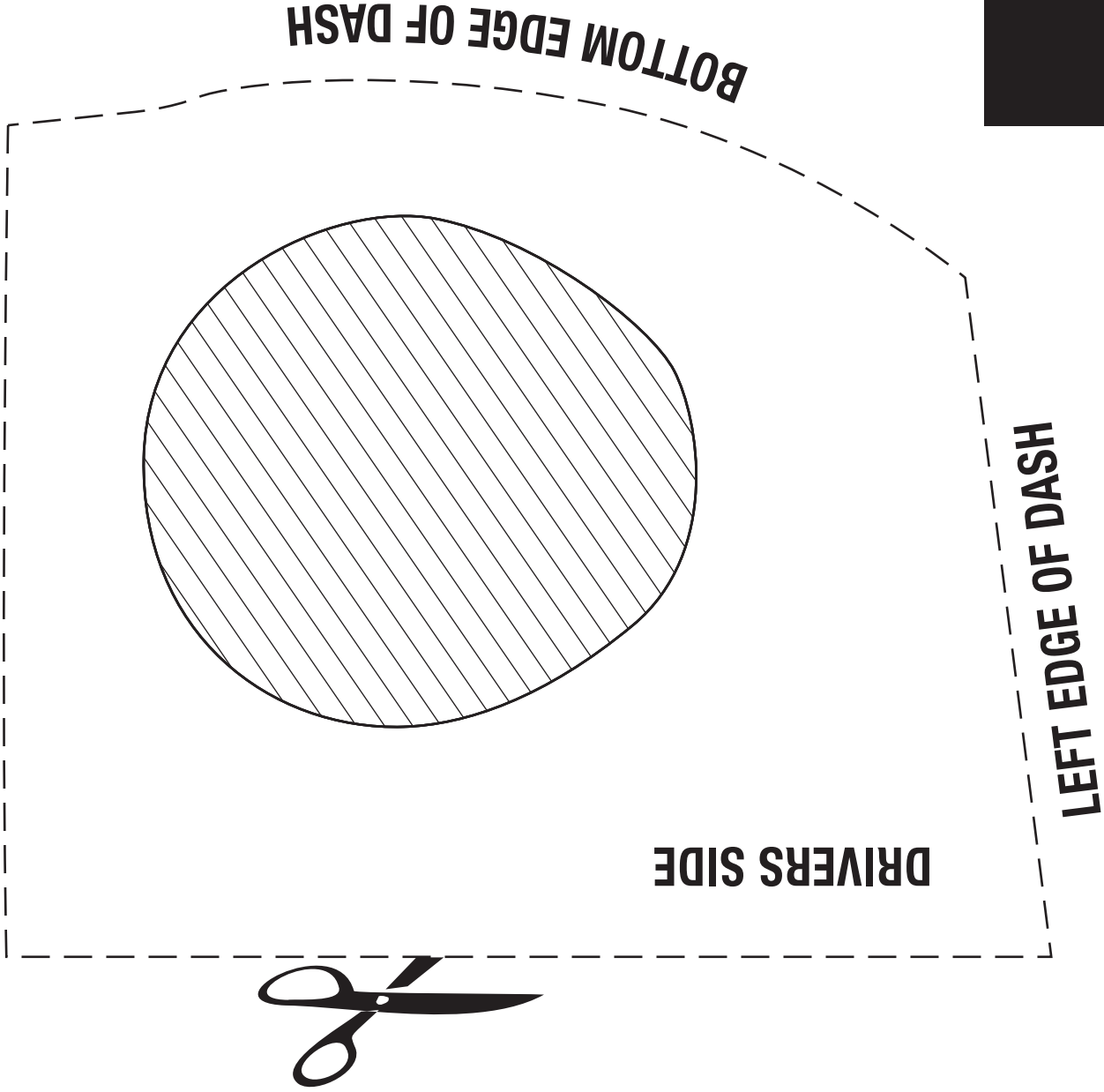

**IF YOU PRINTED THIS MANUAL
PLEASE READ THIS...
Just as a cautionary step, please
measure this box and make sure it
is 1" x 1". Some copiers/printers
may not print at 100% of actual size.**

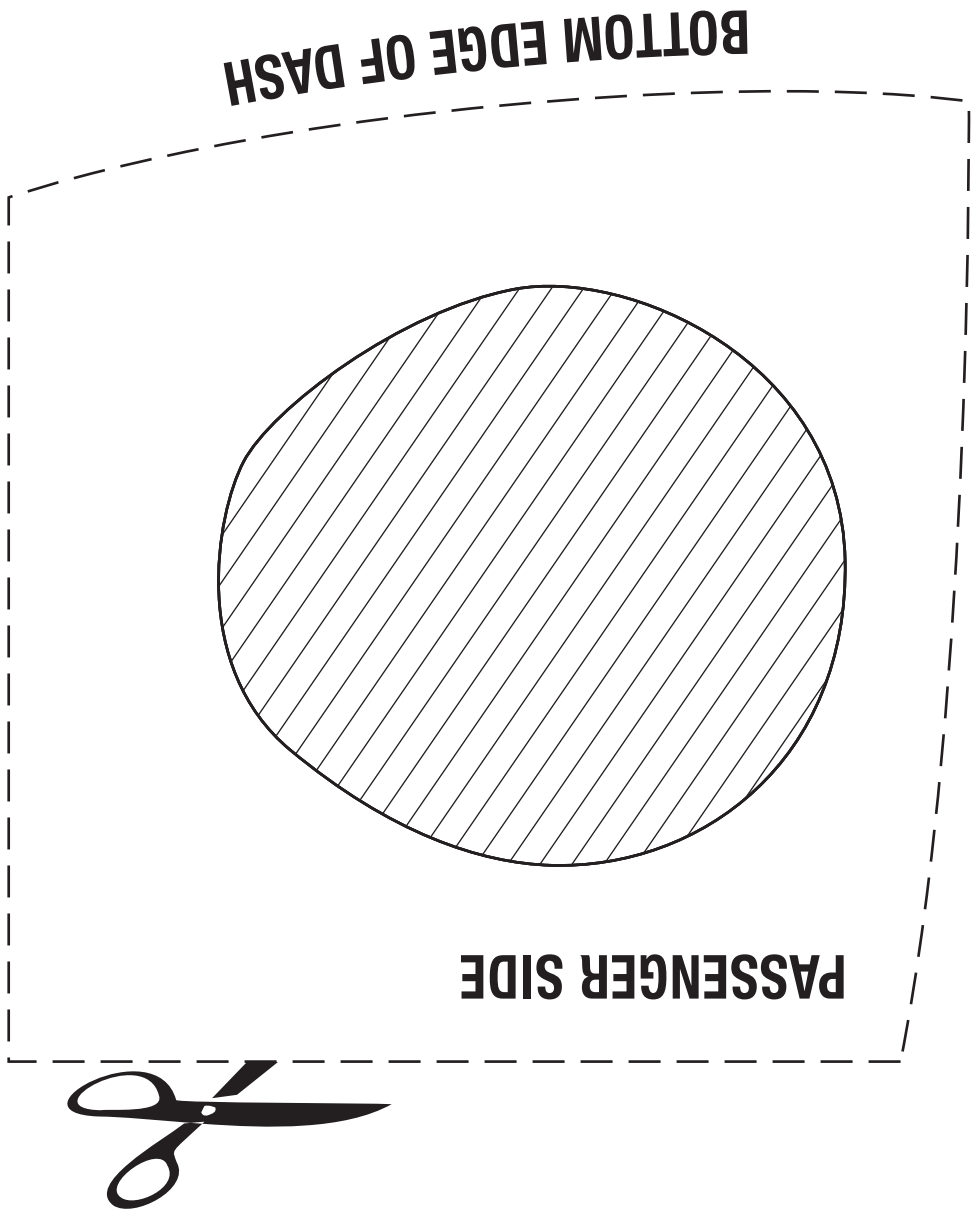

GLOVE BOX OPENING

PASSENGER SIDE

BOTTOM EDGE OF DASH



**IF YOU PRINTED THIS MANUAL
PLEASE READ THIS...
Just as a cautionary step, please
measure this box and make sure it
is 1" x 1". Some copiers/printers
may not print at 100% of actual size.**

**TEMPLATE
CENTER VENT**

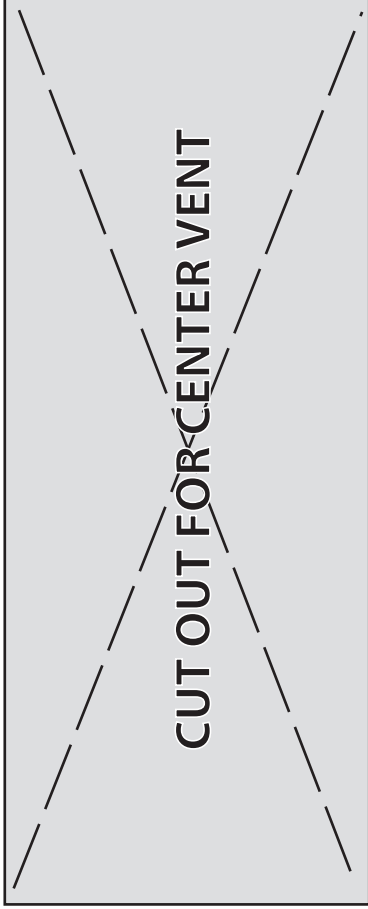

REMOVE the metal bracing contained
within an OEM dash pad

**IF YOU PRINTED THIS MANUAL
PLEASE READ THIS...**

Just as a cautionary step, please
measure this box and make sure it
is 1" x 1". Some copiers/printers
may not print at 100% of actual size.



BOTTOM EDGE OF DASH PAD





(RULER FOR CUTTING HEATER MOTOR HARNESS)

OEM HOLE → ○



IF YOU PRINTED THIS MANUAL PLEASE READ THIS...
Just as a cautionary step, please measure this box and make sure it is 1" x 1". Some copiers/printers may not print at 100% of actual size.

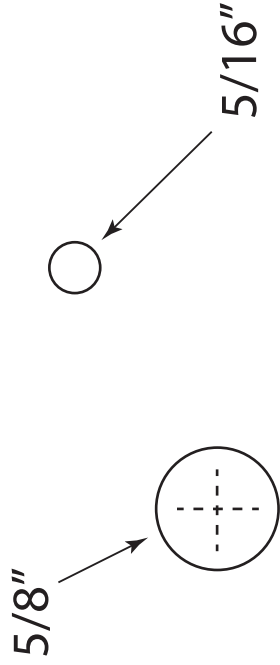

Note: bottom of template is parallel with floor pan

