



Installation Manual

1968 Chevelle/Malibu

DOCUMENT #1-2049

©2013 Classic Auto Air / 1.13vs.1





Congratulations...

You have just purchased the highest quality, best performing A/C system ever designed for your 1968 Chevelle.

To obtain the high level of performance and dependability our systems are known for, please pay close attention to the following instructions. Our installation steps and procedures are derived from a long history of research and development and the combined experience achieved thru thousands of successful installations (and feedback from customers like you). Please remember that our #1 goal is that you'll have a successful installation and a system that performs at a very high level for many years to come.

Before starting, read the instructions carefully, from beginning to end, and follow the proper sequence. On the next page you'll find a safety and general checklist that you should read before starting your installation.

Again, thank you from our entire staff.



Check List, Pre-Installation:

- Before beginning the installation check the shipping box for the correct components. YOUR BOXED UNIT INCLUDES A LIST OF MAJOR COMPONENTS AND A LIST OF BAGGED PARTS. We have a 5 stage check process to make sure you have everything you'll need.
- If your vehicle has been or is being modified, some procedures will need to be adjusted to fit your particular application.**
- A basic cleaning of the engine compartment and interior before beginning will make things go more smoothly.
- Check condition of engine mounts. Excessive engine movement can damage hoses to A/C and/or heater.
- Before starting, check vehicle interior electrical functions (interior lights, radio, horn, etc). Make a note of anything that does not work as it's supposed to. During the installation you might find the opportunity to repair or upgrade non-working or out of date components. When you're ready to start the installation, **DISCONNECT THE BATTERY FIRST.**
- Drain the radiator. Retain the coolant and reuse, or dispose of properly.
- SAFETY FIRST: Wear eye protection while drilling/cutting, deburr sharp edges, and never get in a hurry or force a part.
- Tools: Your installation only requires the basic tools everyone has in their garage, nothing exotic or specific to A/C or Heat equipment.

Procedures, During Installation:

- Fittings: Use one or two drops of mineral oil (supplied with your kit) on ALL rubber o-rings, threads and rear of bump for o-ring where female nut rides. Do not use thread tape or sealants.
- Measure twice (or more), cut once
- Should you have any technical questions, or feel you have defective components (or missing items), call us immediately, we will be glad to assist you. Our toll-free number is listed on every page, we're here to help!**

YOU CAN NOW BEGIN THE INSTALLATION...

A Basic Overview of Automotive A/C....

- 1 Evaporator with Blower Fan** In order to remove the heat from the air in the vehicle, the A/C evaporator allows the refrigerant to absorb the heat from the air passing over it. The blower fan moves cool air out into the car interior.
- 2 Compressor** The compressor pumps and circulates the refrigerant through the system.
- 3 Condenser** The condenser is a heat exchanger mounted at the front of the vehicle. Heat drawn out of the interior of the car is expelled here.
- 4 Receiver/Drier** The drier not only dries refrigerant, it also filters the refrigerant and stores it under certain operating conditions.
- 5 High Pressure Switch** A pressure switch is used to shut down the system if high or low pressure is detected, basically it acts as a safety switch.

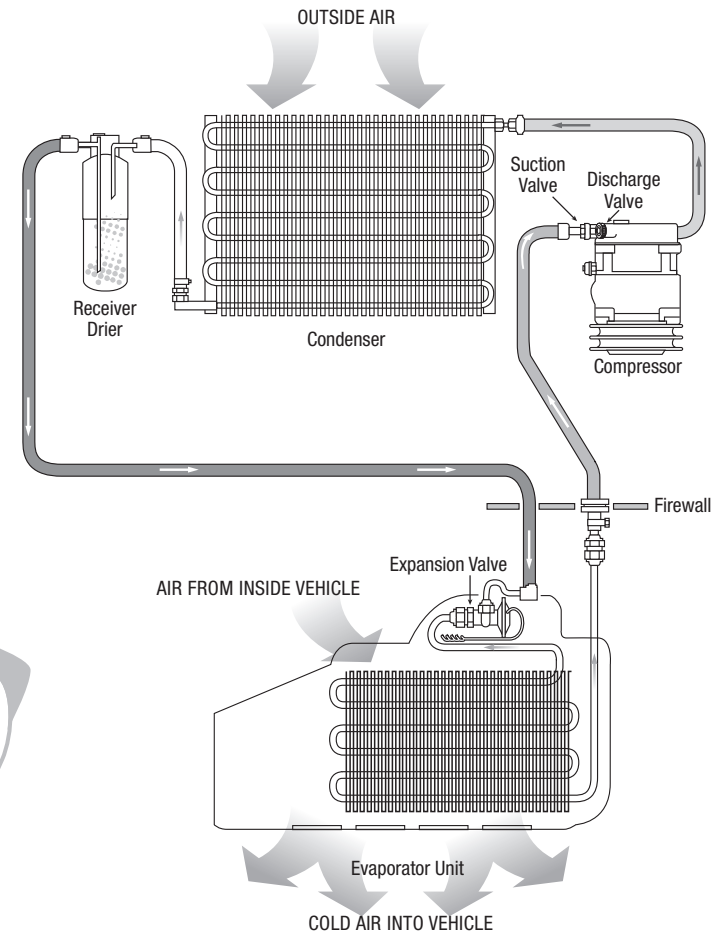
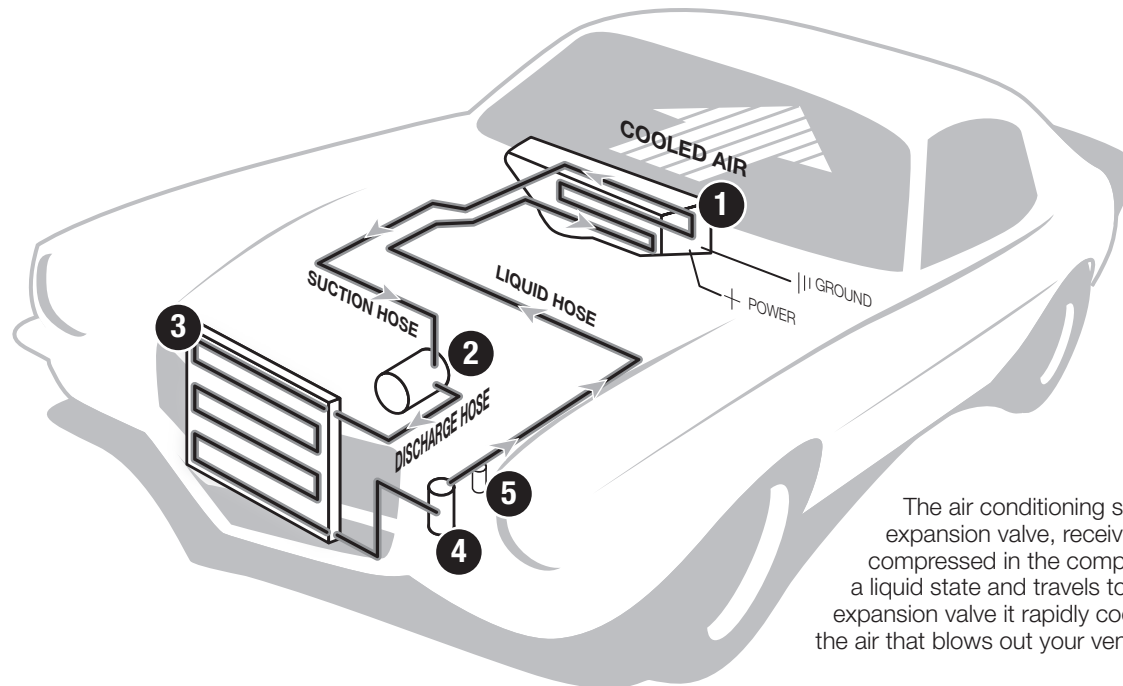

The air conditioning system in your car is comprised of a compressor, condenser, expansion valve, receiver/drier, and evaporator. Refrigerant (also known as Freon) is compressed in the compressor and turns into a gas. In the condenser, this gas is cooled to a liquid state and travels to the expansion valve. As the liquid refrigerant goes through the expansion valve it rapidly cools in the evaporator. A fan blows over the evaporator and cools the air that blows out your vents. The receiver-drier separates gas and liquid.



Control & Operating Instructions

Your new **Perfect Fit-Elite system** offers complete comfort capabilities in virtually every driving condition. This includes temperature control in all of the modes. This system also provides the ability to blend the air between Face, Heat, and Defrost modes simultaneously. To illustrate the various ways you can adjust the airflow direction and temperature - we've provided these handy illustrations and chart to show exactly how you can adjust your **Perfect Fit-Elite** for maximum comfort...



The FAN switch works like the OEM switch, moving the lever away from the OFF indicator powers the system

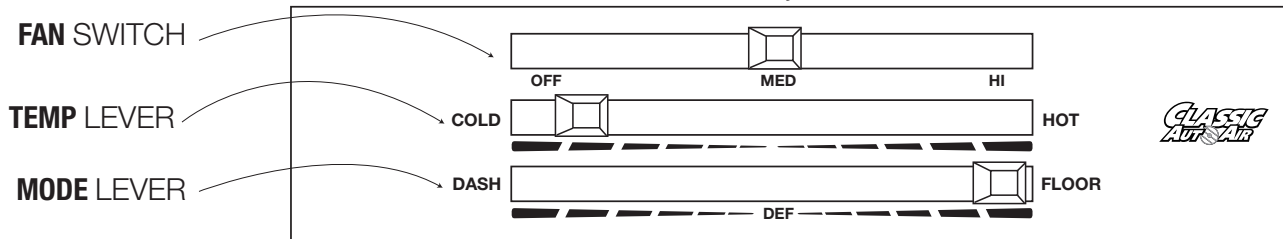

There are 11 levels of adjustment within the range of the DASH/FLOOR lever

The COLD/HOT positions works like any traditional adjustment lever

	DASH					DEF					FLOOR
Left Lever Position	1	2	3	4	5	6	7	8	9	10	11
Distribution	Face A/C 100%	Face A/C 80%	Face A/C 60%	Face A/C 40%	Face A/C 20%	Defrost 100%	Floor 20%	Floor 60%	Floor 40%	Floor 80%	Floor 100%
		Defrost 20%	Defrost 40%	Defrost 60%	Defrost 80%		Defrost 80%	Defrost 40%	Defrost 60%	Defrost 20%	
Compressor State	ON					ON					



Remove Glovebox, Console (optional) Radio and Bezel, and set them aside for reinstall later (see figure 1).

The removal of the Original Heater Assembly can be accomplished by disconnecting three control cables. One is attached to the Heat/Defrost door (see figure 2). One is attached to the Temperature door, and one is attached to the Vent / Heat door (see figure 3). Disconnect the electrical harness from the assembly. Also remove attachment screw located in front of the air inlet (see figure 4).

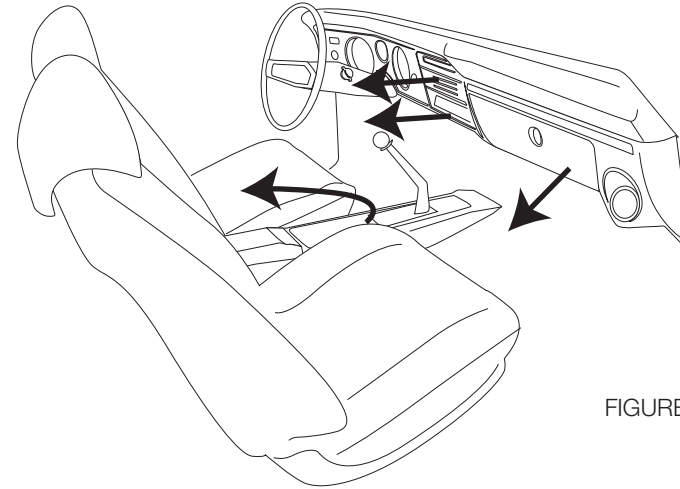

FIGURE 1



When retaining parts it's a good idea to store parts in a zip lock bag, labeled with info where the parts came from and what size/type of tool is needed to reinstall. Cleaning the parts before you need to reinstall them is a good idea too.

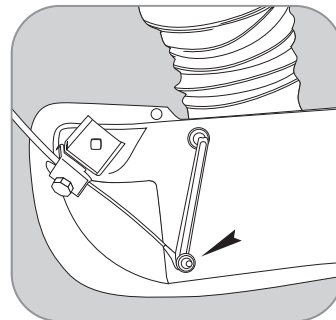

FIGURE 2

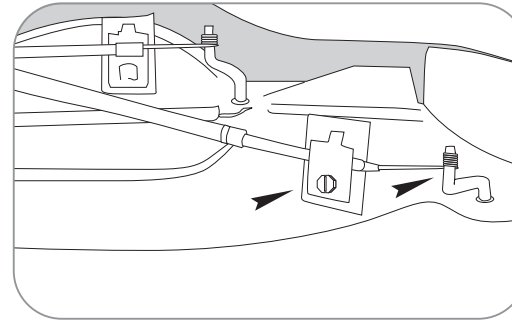

FIGURE 3

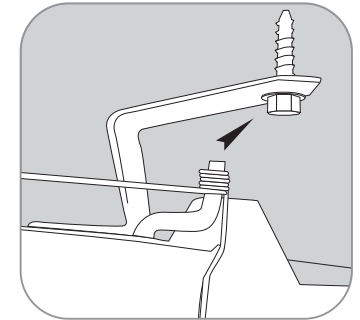
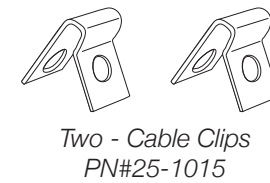
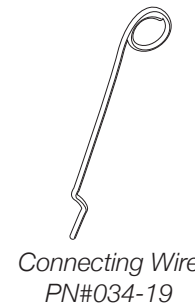
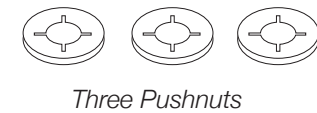
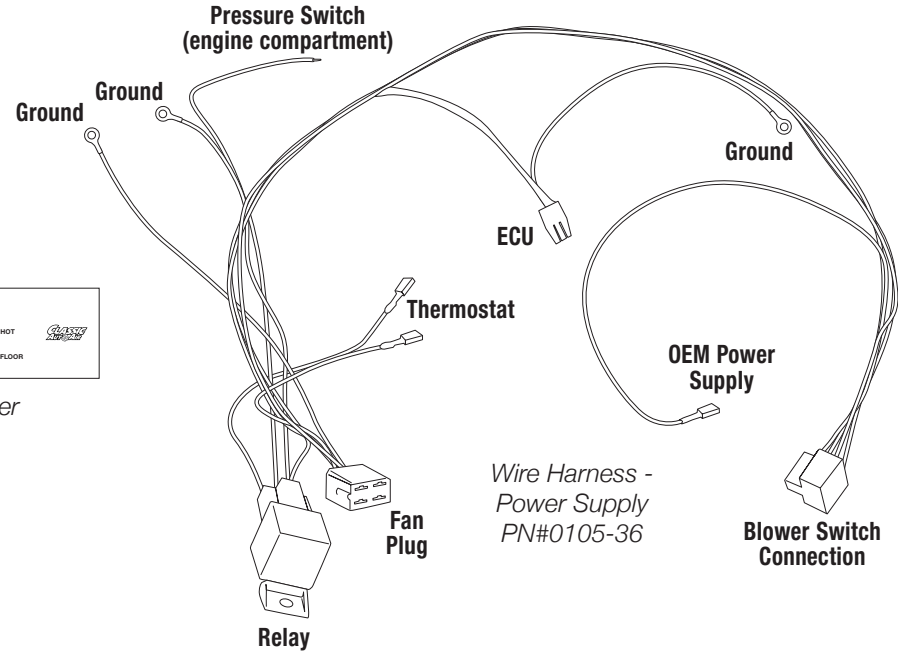
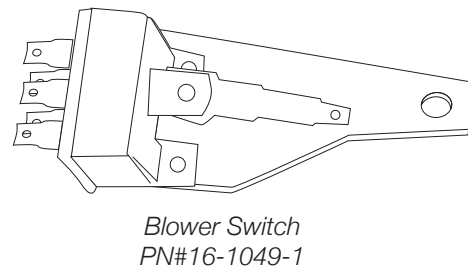
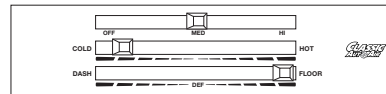
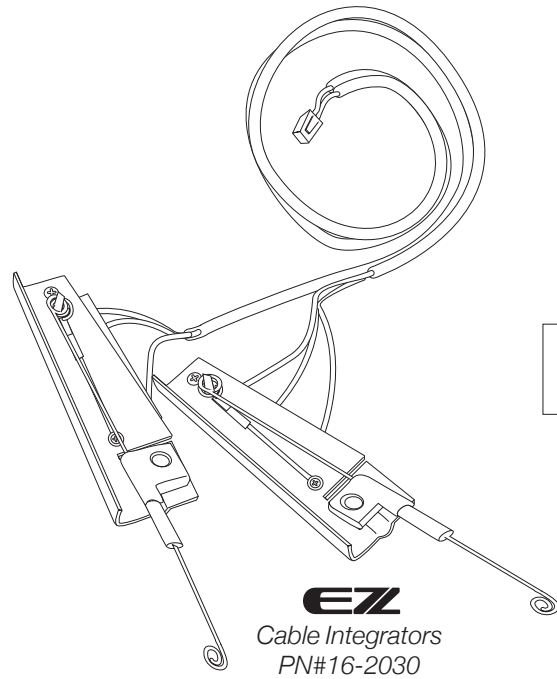

FIGURE 4

THESE ARE THE PARTS YOU WILL FIND IN BAG KIT A

You will use all of these parts and hardware during the next series of installation steps.



NOTE: Illustrations NOT shown actual size

BLOWER SWITCH INSTALLATION:

1) Remove the control cables, the original blower switch (and it's accompanying bracket) and set aside. These will not be reused, but retain the OEM screw, it will be reused (see figure 6).

2) It will be necessary to position, then rotate the blower switch assembly and slide over the screw that will be under the switch. This screw will need to be tightened with a wrench (see figure 7 and 8).

3) Hook the wire through the hole in the blower switch lever, and then route over the control post. Use the push nut to hold the connecting wire (see figure 9).

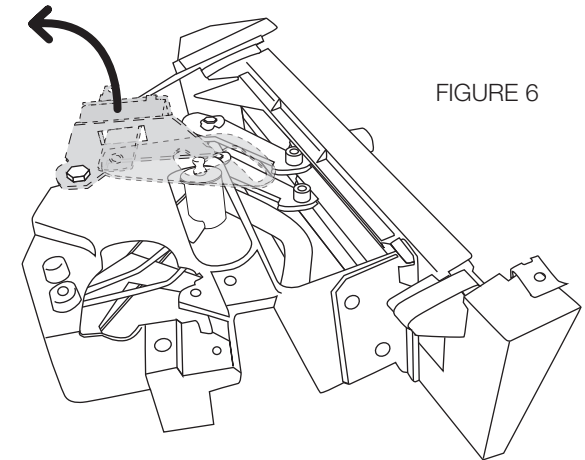

FIGURE 6

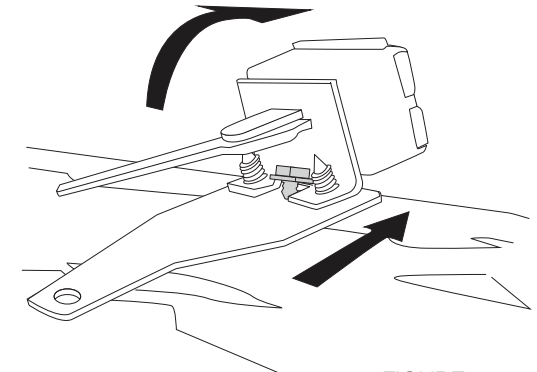

FIGURE 7

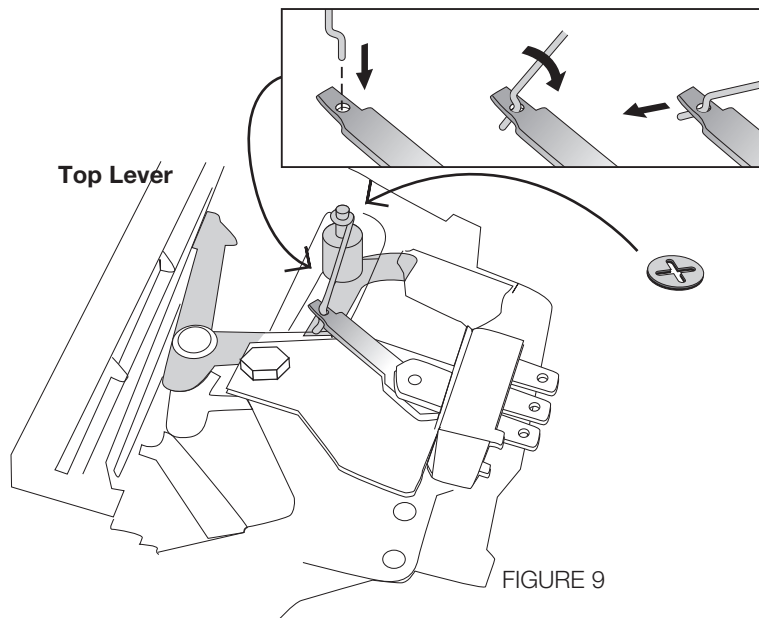

FIGURE 9

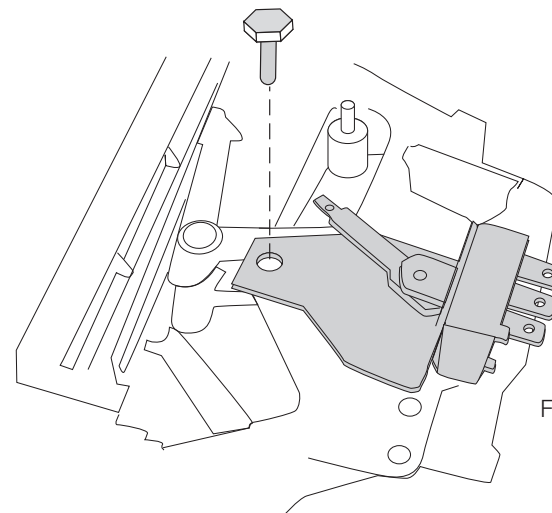

FIGURE 8

Preparing the EZ Cable Integrators for

installation: First place a cable clip over the ends of the **EZ Integrators** (see figure 10). **Test fit these on the final mounting location to make sure you have the cable clips installed in the correct direction so that the integrators can be mounted flush with edge of control head.** Prepare both integrators the same way. It is very important that you place the cable clips over the end of the integrators very securely and evenly. Place the cable clip over the end, press it firmly into place (using needle-nose pliers is recommended).

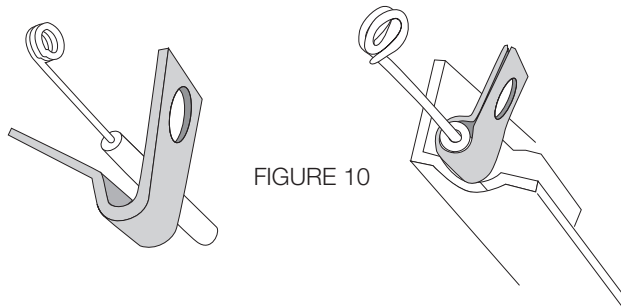

FIGURE 10

Next, attach the **TEMP EZ Cable Integrator** to the control head as shown to the right. The loop ends of the integrator wire will be secured with a push nut (see figures 11 and 12).

VIEW FROM TOP OF CONTROL HEAD

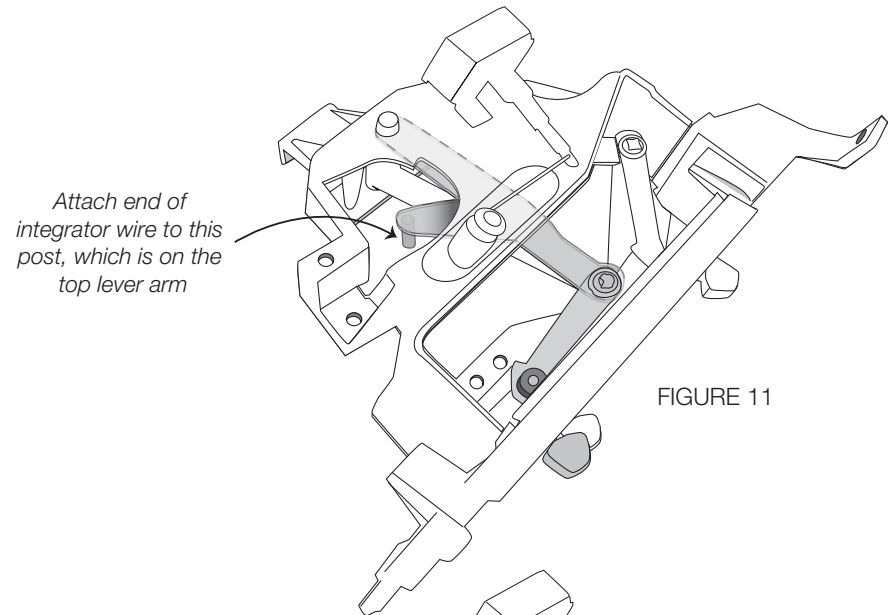

FIGURE 11

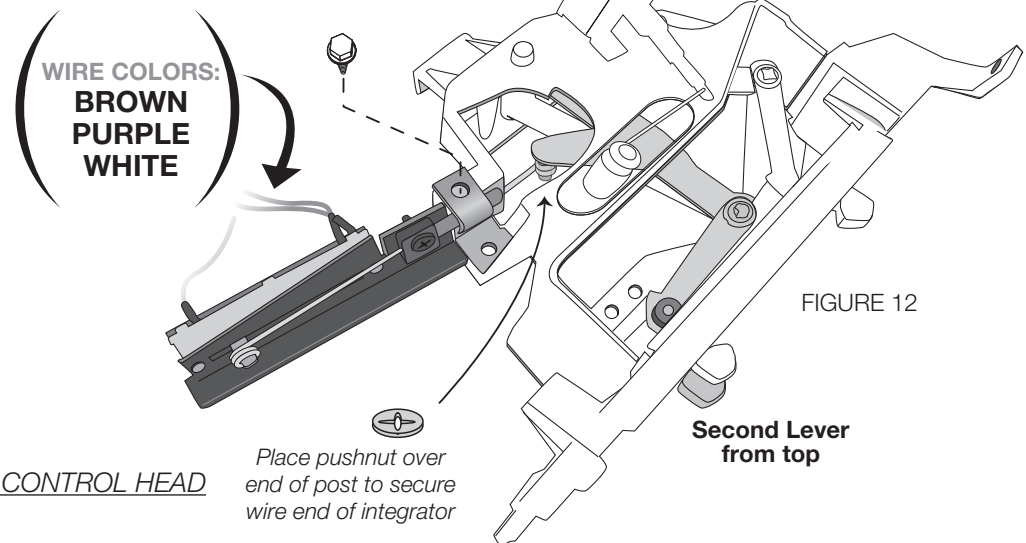

FIGURE 12

VIEW FROM TOP OF CONTROL HEAD

Next, attach the **MODE EZ Cable Integrator** to the control head as shown to the right. The loop ends of the integrator wire will be secured with a push nut (see figure 13 and 14).

Plug the harness blower switch connection into the back of the control head and insert the entire harness and switch component back into the dash.

VIEW FROM BOTTOM OF CONTROL HEAD

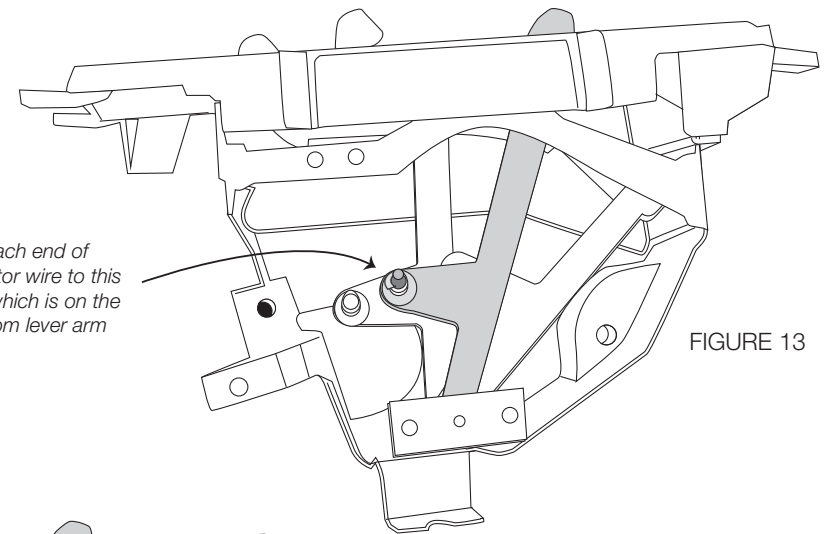

FIGURE 13

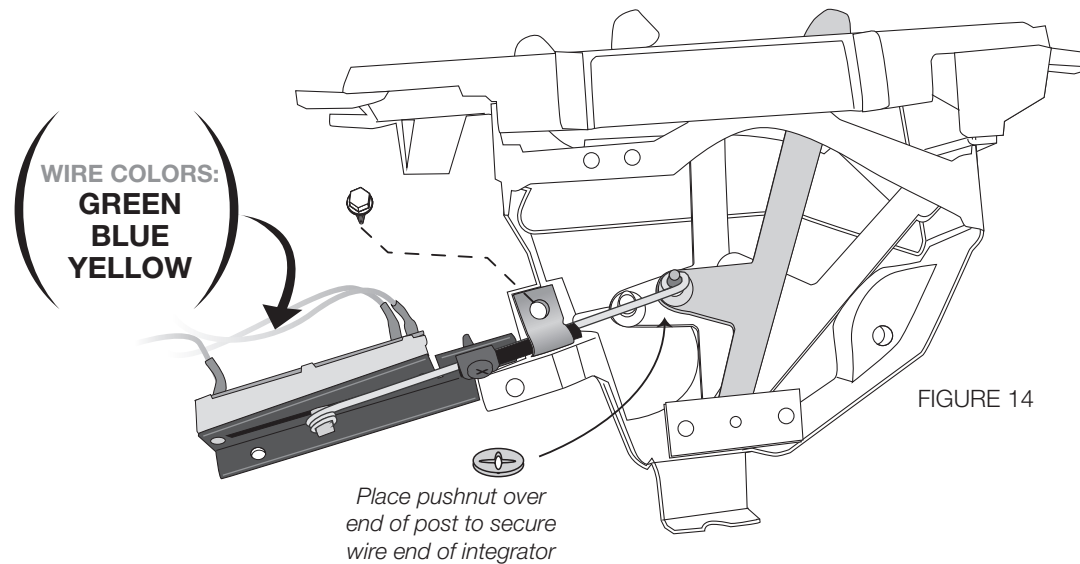
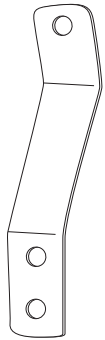

FIGURE 14

THESE ARE THE PARTS YOU WILL FIND IN BAG KIT B

You will use all of these parts and hardware during the next series of installation steps.



Evaporator Firewall Support Bracket
PN#0023-7

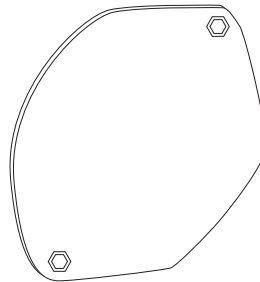

Fresh Air Inlet Block Off
PN#10-1048-2

Liquid Tube
PN#0034-9

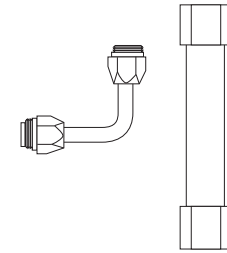

Suction Tube
PN#0034-10



#6 and #10 O-rings

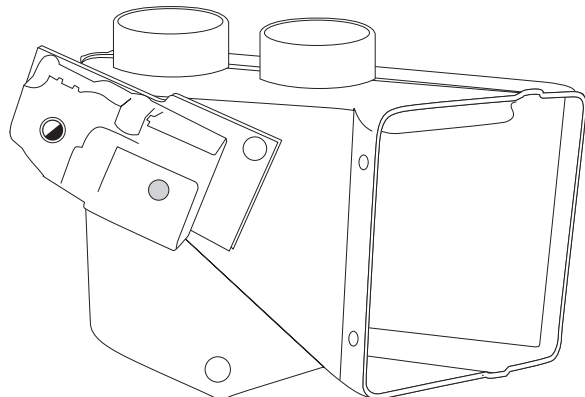

Defrost/Heat Duct Assembly
PN#2-2049-1

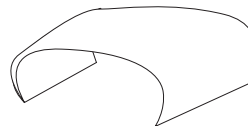

One Bulb Clamp



Four #10 - 10 x 5/8" Phillips Screws



One Male Spade Connector



Two #10 - 16 x 3/4" Tek Screws



Refrigerant Tape

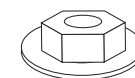

Flange Nuts

Illustrations NOT shown actual size

Locate the original wiring harness that supplied power to the OEM heater switch. Measure 4" from the connector, cut all the wires, and attach a 1/4" insulated male spade connector to the OEM power supply wire (GM normally used a brown wire for power, see figure 15). Within the OEM fuse box upgrade the factory HEATER fuse with a 20 amp fuse **(VERY IMPORTANT!!!)**.

Looking thru the glove box door opening, locate the bottom left mounting hole in the firewall that attached the original heater motor, and follow the directions for drilling as shown below. From inside of the vehicle drill a 5/8" dia. hole for the drain tube.

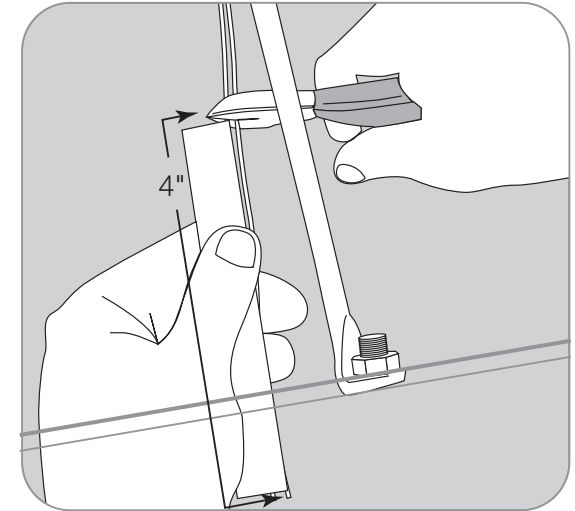
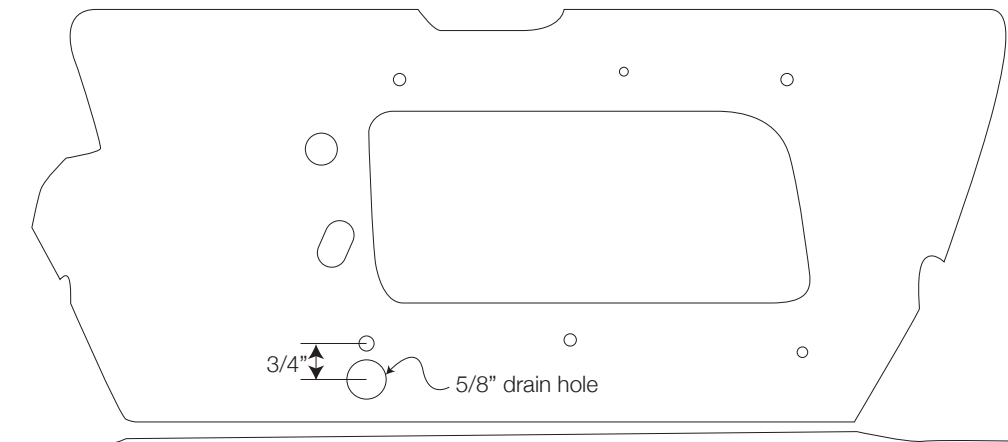

FIGURE 15

**THIS IS
FROM THE INSIDE
OF THE VEHICLE!**



You can now begin installing your Classic Air Perfect Fit Elite System.

Within the engine compartment area, Install Fresh Air inlet block-off over the OEM fan opening using the original screws (it will also tuck in behind the edge of the hood hinge... tip: leave the hinge loose for now...)

Remove evaporator unit from box and place on a flat work surface.

Locate the defrost/heat duct assembly and attach to the evaporator using two #10 - 10 x 5/8" Phillips screws (see figure 16). NOTE: Be sure that the s-clips are pushed over rear flange on evaporator.

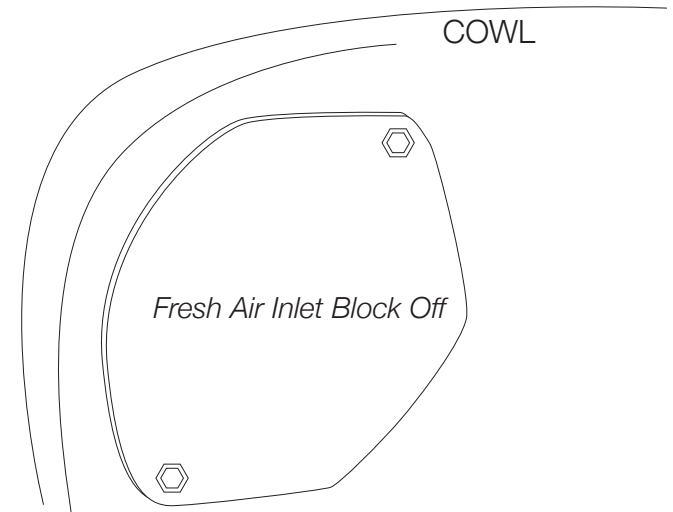

Take a minute to familiarize yourself with the evaporator unit:

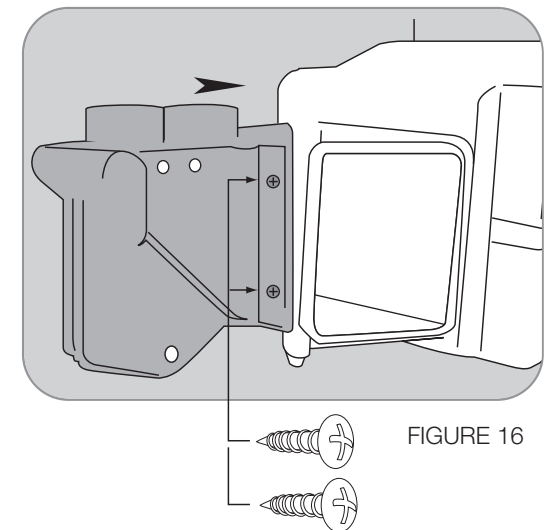
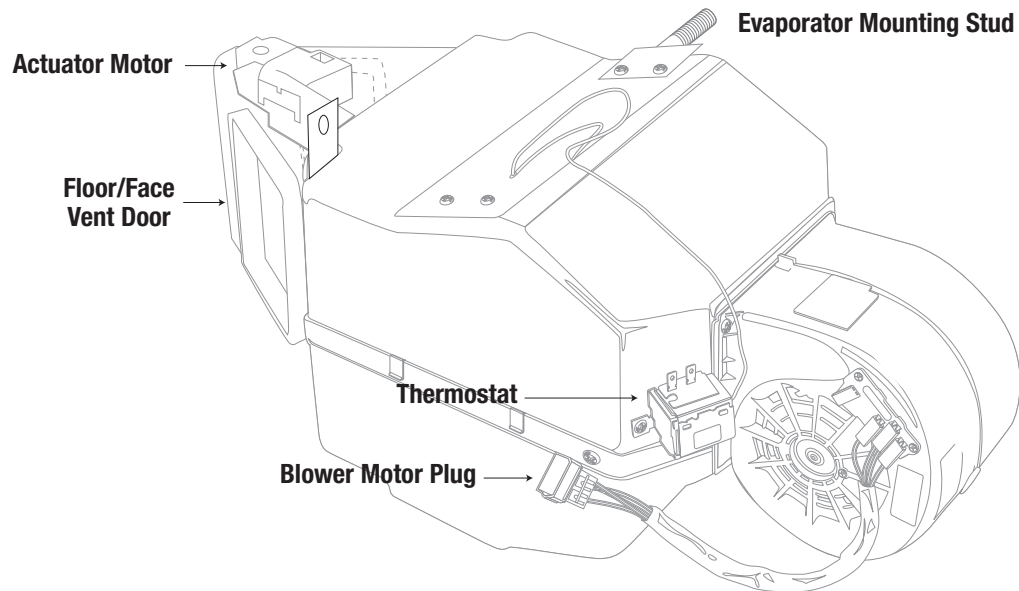
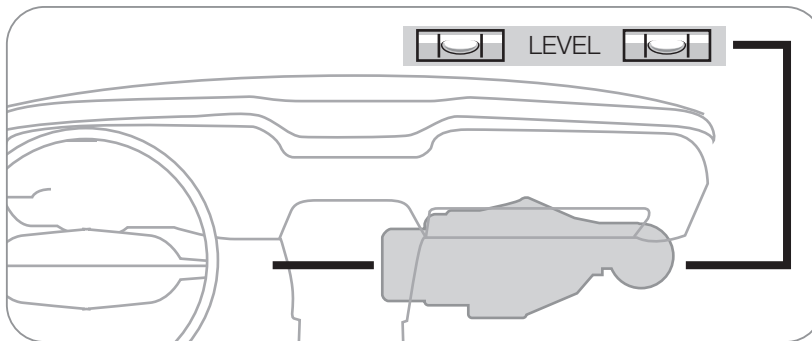

FIGURE 16

Installing the complete evaporator unit under the dash will go much easier with the help of a friend. Once the unit has been rolled up under the dash, one person can hold the unit in place while the other person can be ready at the firewall area with the included flange nut to secure the unit (see figure 17).

Now the unit will be easy to level and secure. Leveling the unit is very important to insure proper drainage of condensation.



Be sure to align the evaporator unit level with the bottom of instrument panel (assuming the vehicle is sitting level) as shown above, but with a small degree of tilt toward the back to allow proper drain of condensation.

Flange Nut attached to stud protruding thru original mounting hole

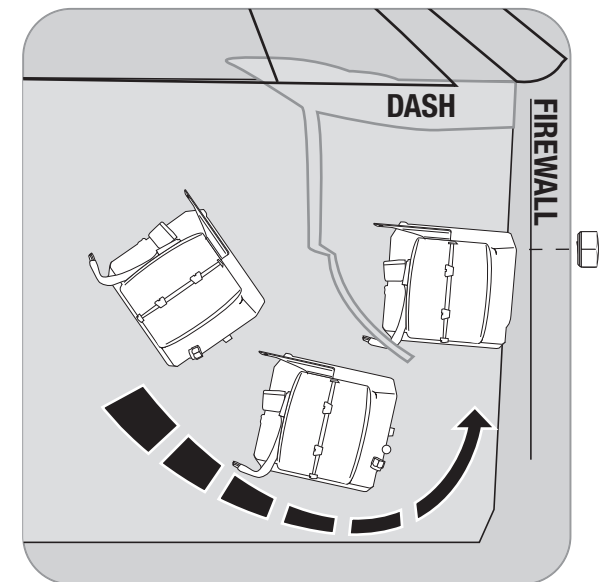
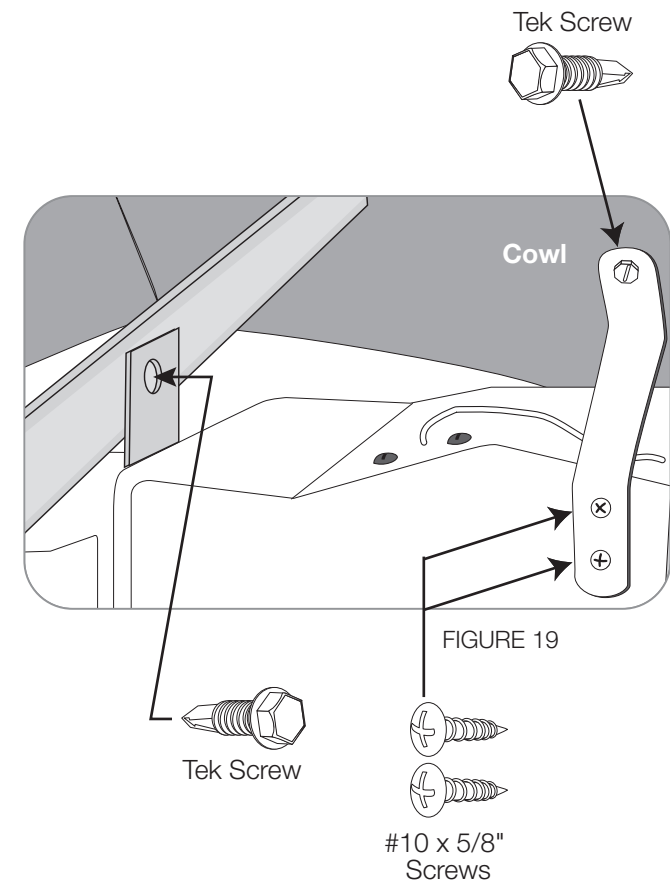
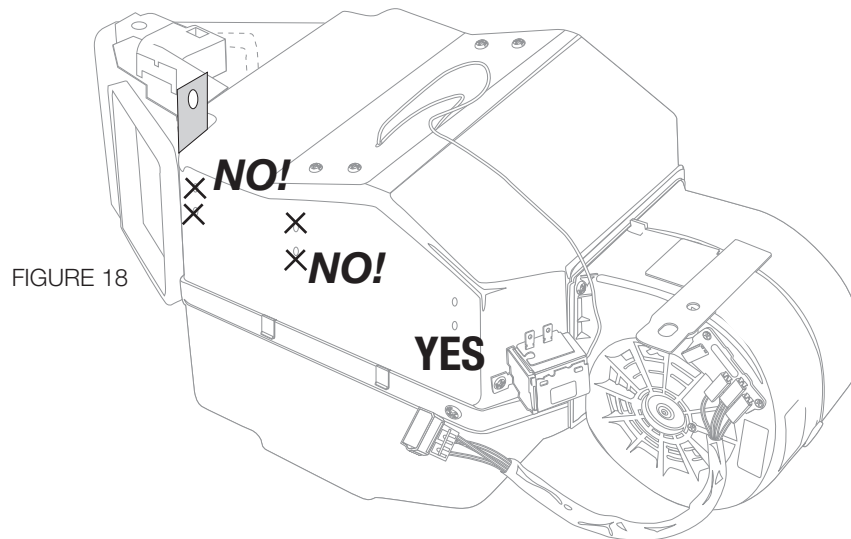

FIGURE 17

Locate in the UPPER MOUNTING BRACKET and attach to evaporator unit using two #10 - 10 x 5/8" Phillips screws. Attach other end to the cowl with a #10 - 16 x 3/4" Tek Screw (see figure 18). **IMPORTANT NOTE: On the side of the main unit you will see several holes for mounting holes... ONLY USE THE ONES ON THE FAR RIGHT FOR THIS BRACKET!** Do not tap into the other holes for any reason (see figure 25). Also, use a screwdriver and hand-power and do not over-tighten so you don't strip the holes.

The other mounting point is accomplished by threading a Tek Screw thru the bracket already affixed to the evaporator and into the dash brace that is right above the evaporator unit (see figure 19).



Install liquid line onto the Expansion valve (TXV) as shown. Use #6 o-ring and (2) drops of mineral oil on the o-ring and tighten securely.

Install Suction Tube to the outlet on the unit as shown. Use #10 o-ring and (2) drops of mineral oil on the o-ring and tighten securely.

Locate Sensing Coil attached to Expansion valve (TXV) and utilizing Bulb Clamp, attach to the Suction Tube (see figure 20).

CAUTION: THE SYSTEM WILL NOT FUNCTION PROPERLY IF THE SENSING COIL IS NOT CLAMPED IN THE CORRECT POSITION. SEE PICTURE.

Wrap Suction Tube and Sensing Coil with the refrigerant tape provided (use approx. 1/2 of the tape). Be sure that all of the exposed metal is covered.

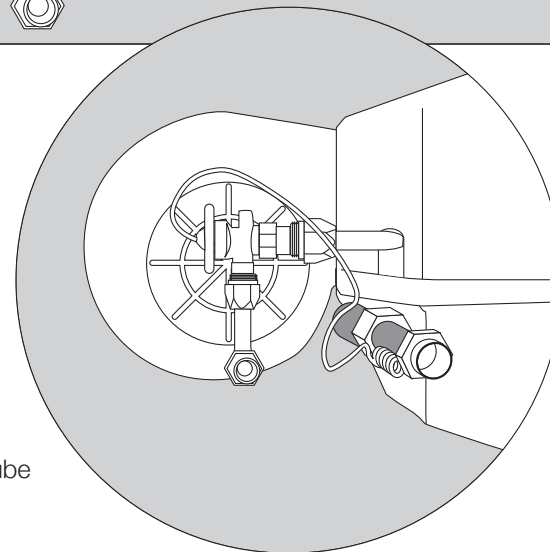
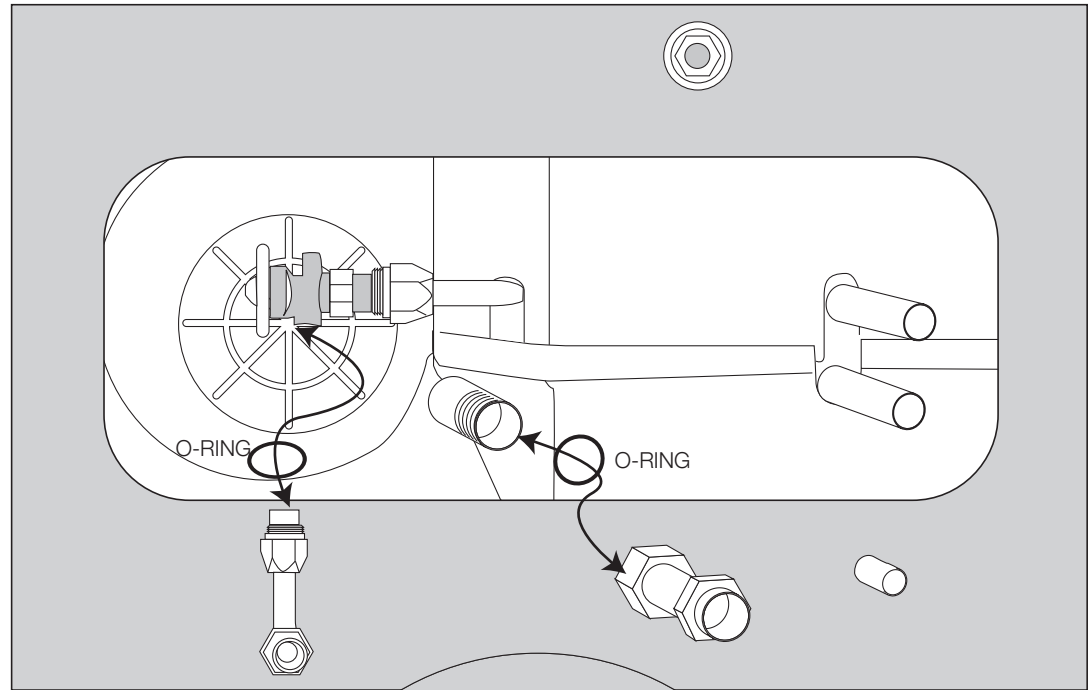
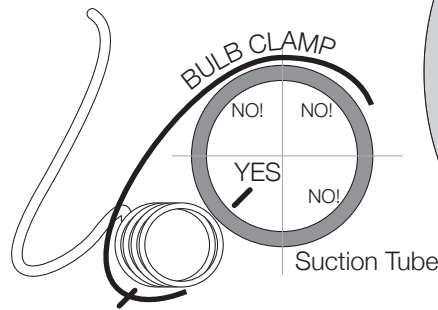
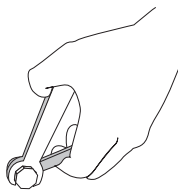

FIGURE 20



**Reminder...
Use two
wrenches to
tighten o-ring
fittings**



THESE ARE THE PARTS YOU WILL FIND IN BAG KIT C

You will use all of these parts and hardware during the next series of installation steps.

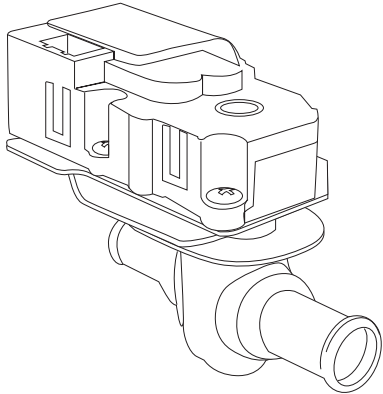

Electronic Water Control Valve
PN#16-1081-2



Clear Plastic Drain Tube

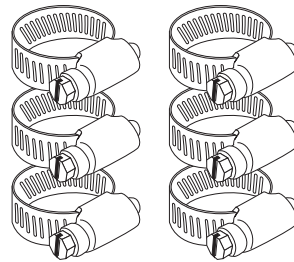

Six Worm Gear Clamps

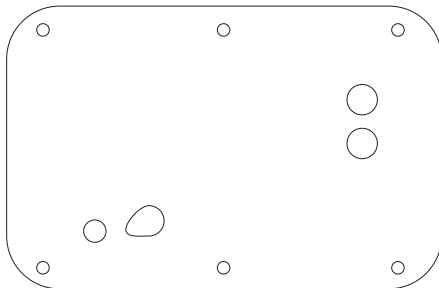

Firewall Block Off
PN#10-1049-1

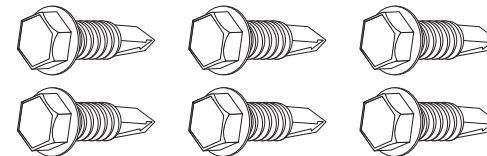

Six #10 - 16 x 3/4" Tek Screws

Illustrations NOT shown actual size

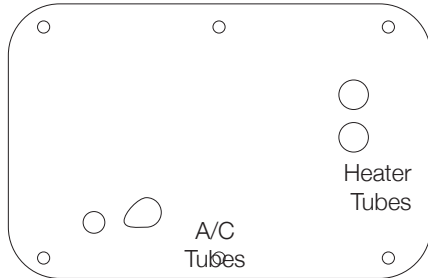

It may be necessary to manipulate the tubes slightly to get proper fitment thru the block-off plate

In **Bag Kit C** you'll find the firewall block off. Install this over the hose connections coming thru the firewall within the engine compartment (you'll need to loosen your hood hinge and tuck one corner behind it). Attach with six #10 - 16 x 3/4" Tek screws. **TIP: This would be a good time to "jump" ahead a bit, and remove the ORANGE cable from Bag Kit D and route it thru block off plate, it will be plugged into the electronic water valve.** Seal around the tubes with the included refrigerant tape. This will keep unwanted moisture and debris from entering thru the firewall... so seal carefully and thoroughly.

IMPORTANT NOTICE: PROPER INSTALLATION OF WATER VALVE INSTRUCTIONS!!!

Classic Auto Air has done extensive testing on the correct method to install the water valve in order to get a repeatable and progressive temperature control. **Your water valve MUST be installed per these instructions!... (if not, your system will not work properly... and that's an absolute fact).**

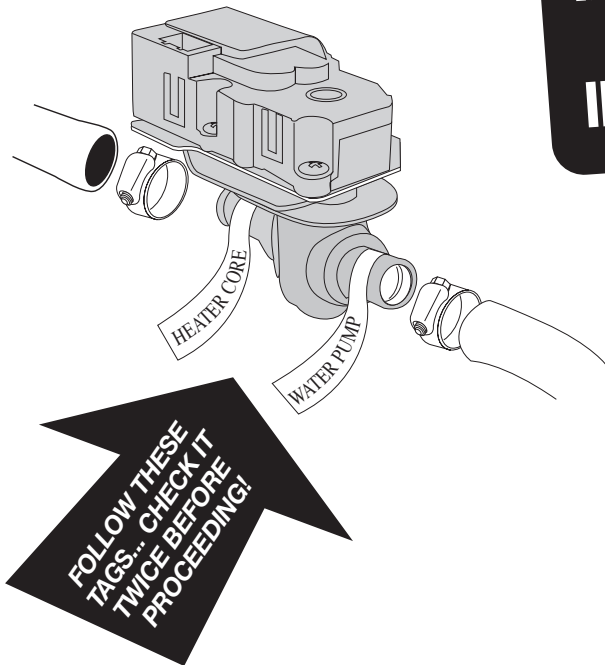

The **lower** connection on the tubes coming thru the block off assembly is going to be routed to the water outlet on the intake manifold. Attach your hose with cable clamps on both ends and route where it will not interfere with linkage or come in contact with exhaust manifolds or headers.

The **upper** port coming thru the firewall will be routed to and thru your new your electronic water valve (the water valve is marked for easy installation). First Attach a 6" piece of 5/8" dia. heater hose with the supplied worm gear clamp. Attach to the inlet side of the water valve using another supplied hose clamp. Attach a heater hose from the outlet side of the electronic water valve and route to the connection on the water pump.

Insert a 6" piece of the clear, 1/2" drain tube we included through the hole previously drilled and attach over the drain nipple. Seal around tube with refrigerant tape.



THESE ARE THE PARTS YOU WILL FIND IN BAG KIT D

You will use all of these parts and hardware during the next series of installation steps.

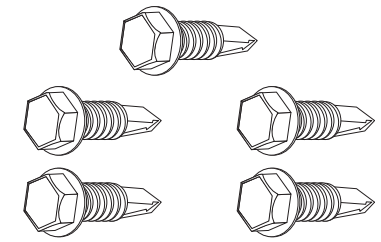

Five #10 - 16 x 3/4" Tek Screws

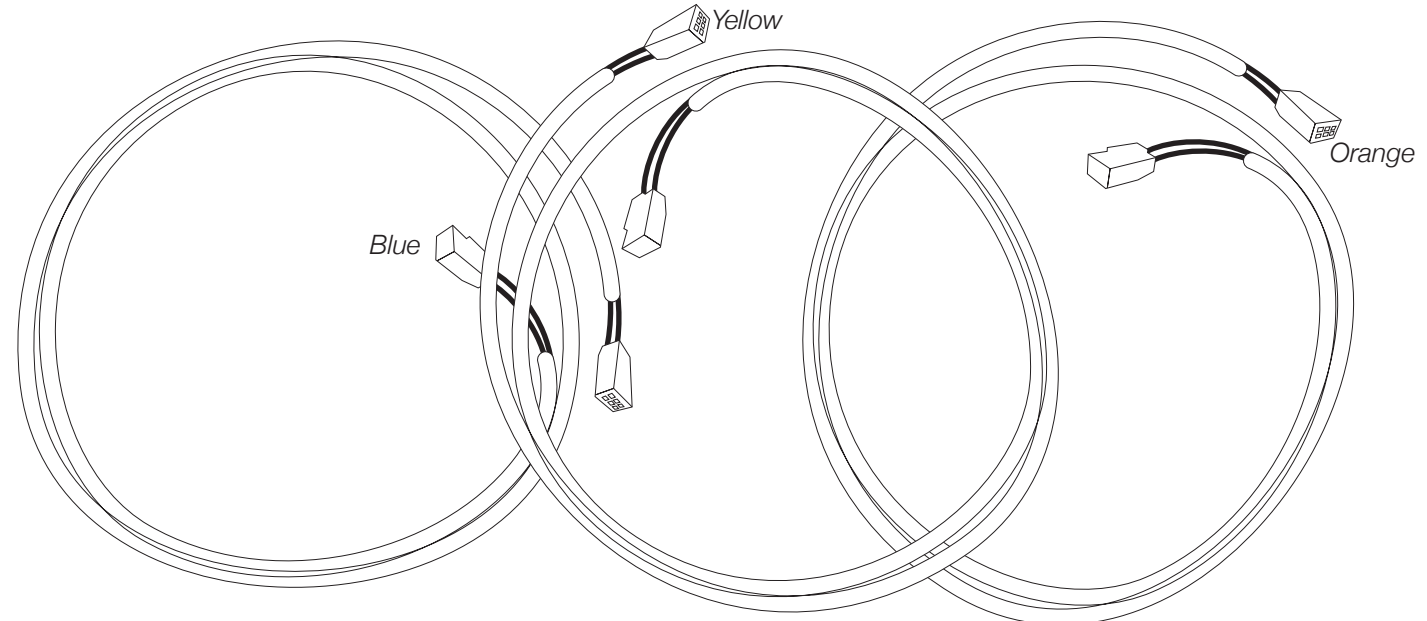

Illustrations NOT shown actual size

We've included enough wire length to allow you to mount the ECU in a variety of places. It is very important that you mount this in a place where it will stay dry and that vibration is at a minimum. Also make sure that where ever you mount it does not interfere with any moving controls or cables. We recommend mounting it just above the right hand side of the main unit using the included tek-screws. **IMPORTANT! DON'T MOUNT THE ECU PERMANENTLY JUST YET. THAT CAN BE DONE AFTER YOU CALIBRATE THE UNIT.**

In **Bag Kit D** you will find three wiring harnesses with connections at each end. Plug the harness with YELLOW band into the YELLOW ECU port and the other end into the servo motor on the main unit (motor is marked with YELLOW INDICATOR). Repeat this process for the other two harnesses, following the color coding indicated on cables and ports. Attach cable in the engine compartment to the electronic water valve (see figure 21). Using one of the CAP PLUGS provided, slot it and install over the heater hose/cable.

NOTE: The GREEN harness connection will be made from the harness you previously installed, just plug the loose connection in the CONTROL port on the ECU.

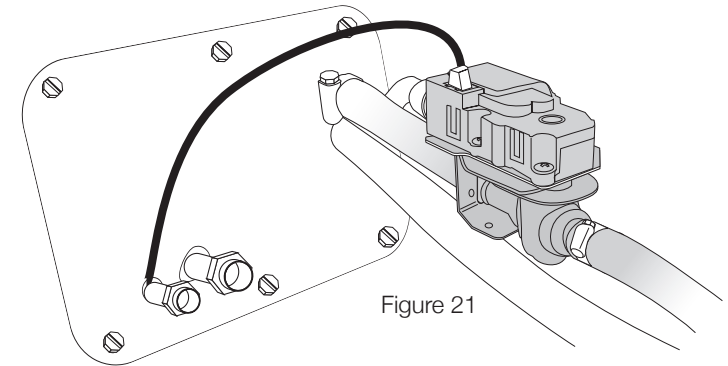
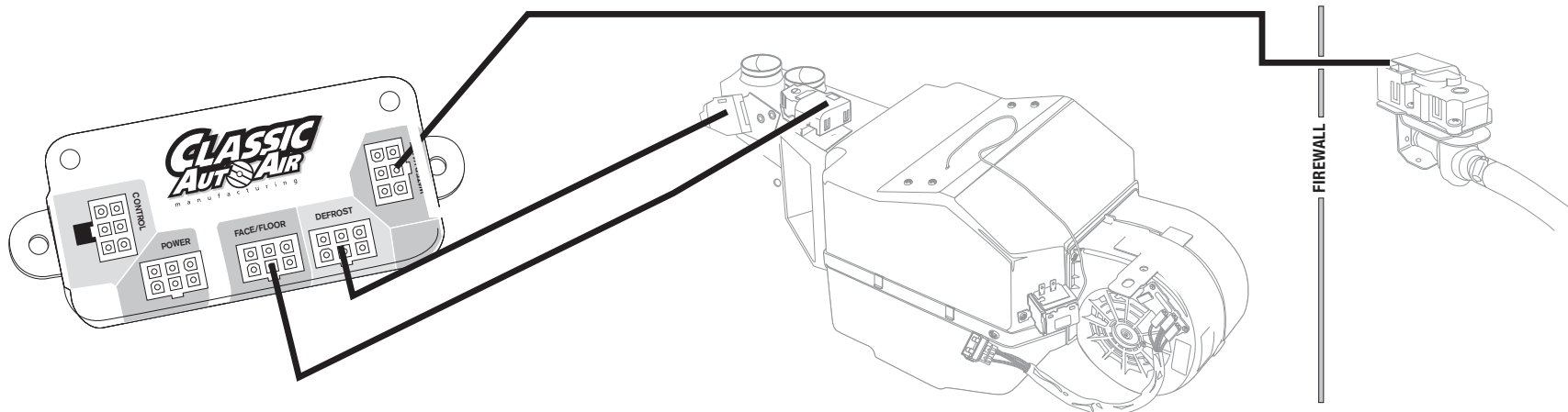
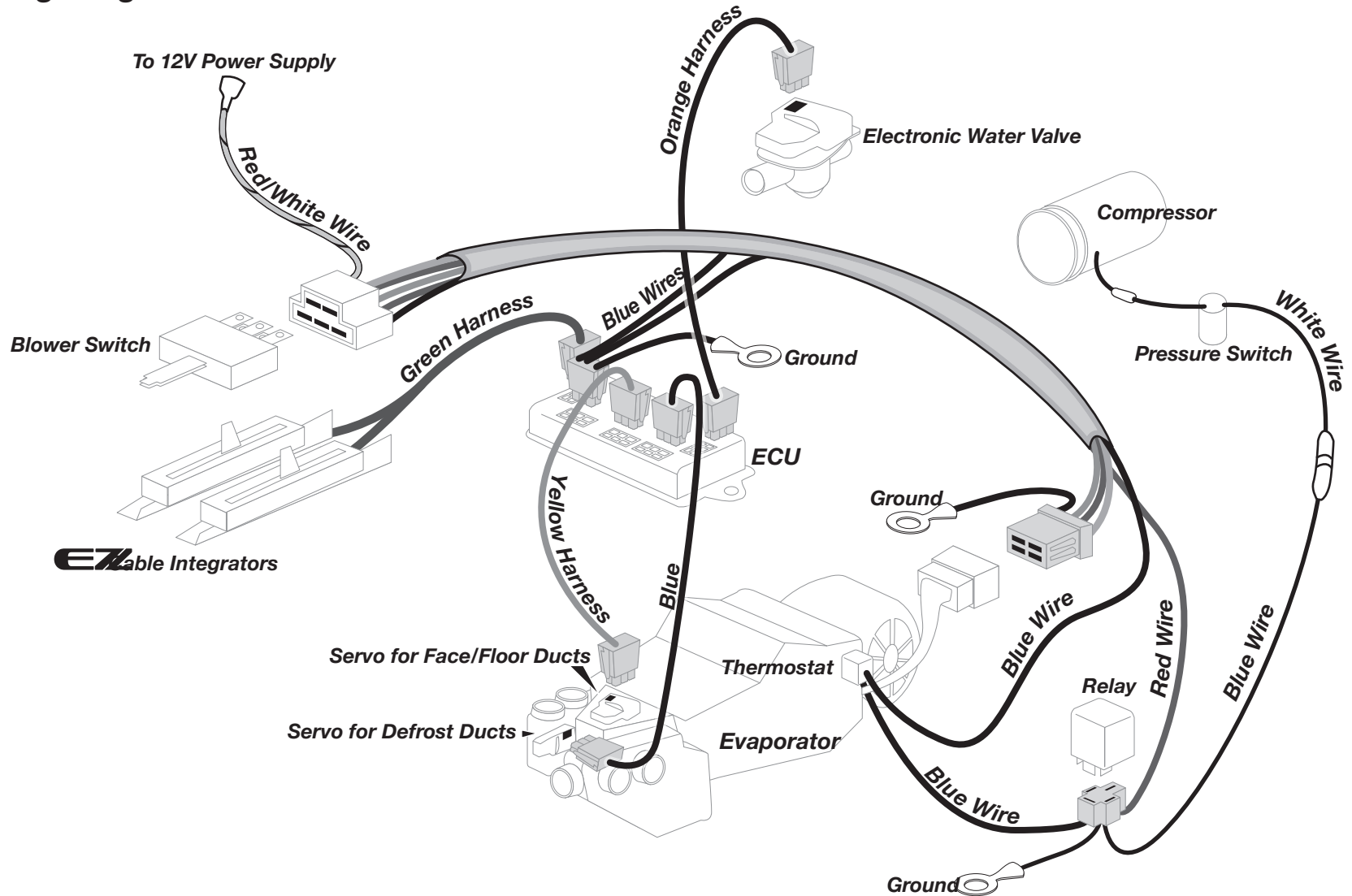

Figure 21



Wiring Diagram/Overview



REMINDER: BE SURE THAT THE WIRING HARNESS DOES NOT INTERFERE WITH THE OPERATION OF ANY CONTROLS.



Temporarily reconnect the car battery at this time. You will need a full 12 volts to complete the calibration.

WELCOME TO EZ CALIBRATION...

Follow these directions carefully and your unit will be calibrated in just a few minutes. Before we boxed and shipped your unit, we tested and calibrated it to factory specifications to make sure it is capable of operating at maximum efficiency. However, the unit must still be calibrated to your specific vehicle and controls. This is an easy process that can be done in a few steps. If for any reason your unit does not calibrate properly the first time, just turn off the unit and rerun the setup process. **NOTE: When you move a knob to a new position, do it in ONE continuous motion.**

#1

Plug CALIBRATION KEY into ECU

#2

Position your controls like this example.

#3

Move FAN control to medium in one motion...

LED ON 1 Second Later... LED OFF

#4

Move MODE control to DASH in one motion...

LED ON 1 Second Later... LED OFF

#5

Move TEMP control to HOT in one motion...

LED ON 1 Second Later... LED OFF

#6

After 1 second the LED turns back ON

You may be able to hear the internal door(s) move back and forth...

LED ON Approx. 30 Seconds Later... LED OFF

#7

Move the FAN knob to OFF (powers off unit)

#8

REMOVE KEY AND STORE IN SAFE PLACE

That's it. Your unit is now fully calibrated. Disconnect the battery and move on to the next phase....

THESE ARE THE PARTS YOU WILL FIND IN BAG KITS E, F, and G

You will use all of these parts and hardware during the next series of installation steps.

Bag E

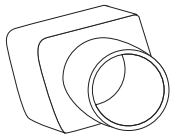

Defrost Adaptor
Left
PN#034-14

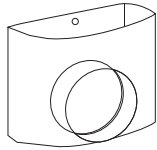

Defrost Adaptor
Right
PN#034-15



Four #10 - 10 x 5/8" Phillips Screws



Foam tape

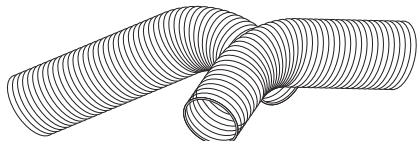

Two Duct Hoses, 2" I.D.



Four Zip-Ties

Bag F

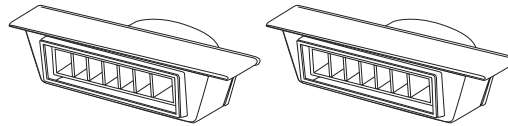

Two Lower Dash Louvers
PN#1972-1



Four #10 - 16 x 3/4" Tek Screws

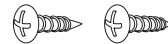

Two #10 - 16 x 5/8" Phillips Screws

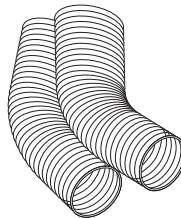

Two Duct Hoses, 2" I.D.

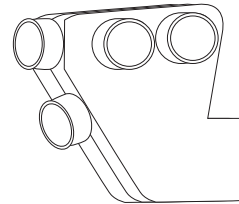

Face/Floor Assembly
PN#2-2050-1



Four Zip-Ties

Bag G

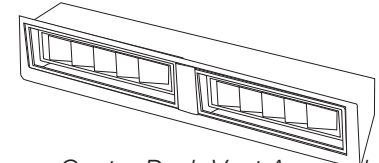

Center Dash Vent Assembly
PN#2-1049-1

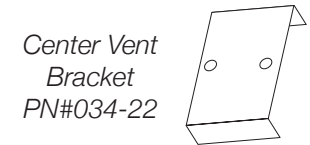

Center Vent
Bracket
PN#034-22



Two #8 x 3/8" Phillips Screws

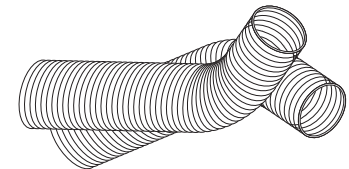

Two Duct Hoses, 2" I.D.



Four Zip-Ties

BAG KIT E: Remove defrost duct and place on a flat area like a workbench. We've included templates for modifying both sides of the duct... cut out and tape the templates in place over the duct. Cut the defrost duct into two pieces as indicated, discarding the lower half. Using the 1/4" x 1/2" open cell foam we've included, attach foam over end of the drivers side duct Next attach the included end adaptor and fasten with two #8 x 1/2 screws (see figures 22 and 23).

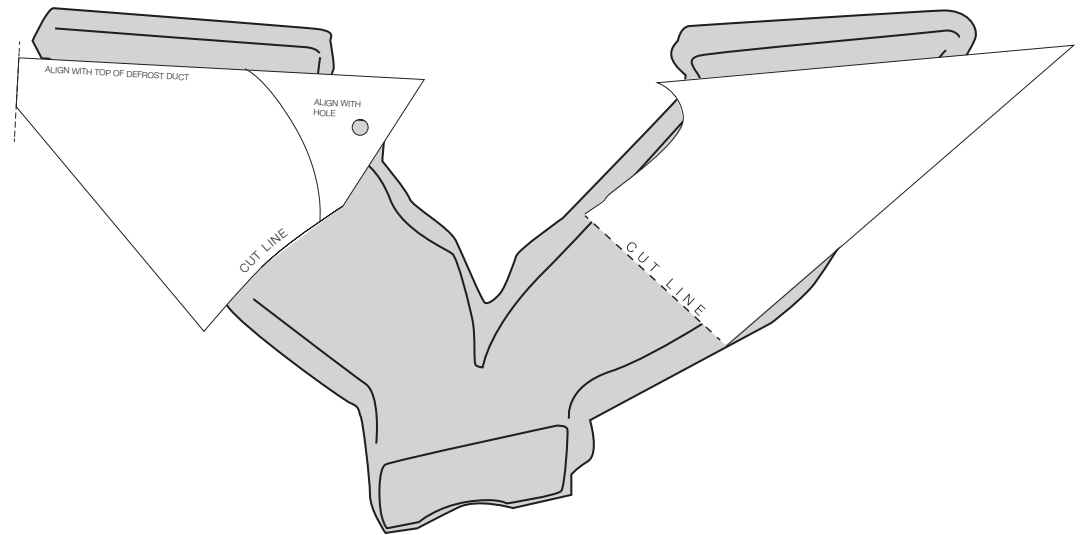

Drivers Side Modifications

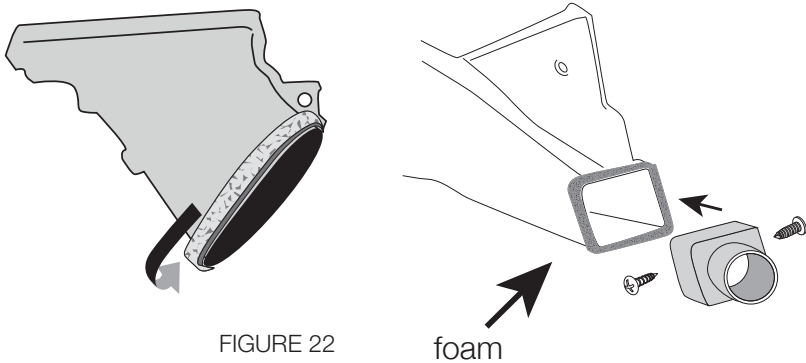

FIGURE 22

Passenger Side Modifications

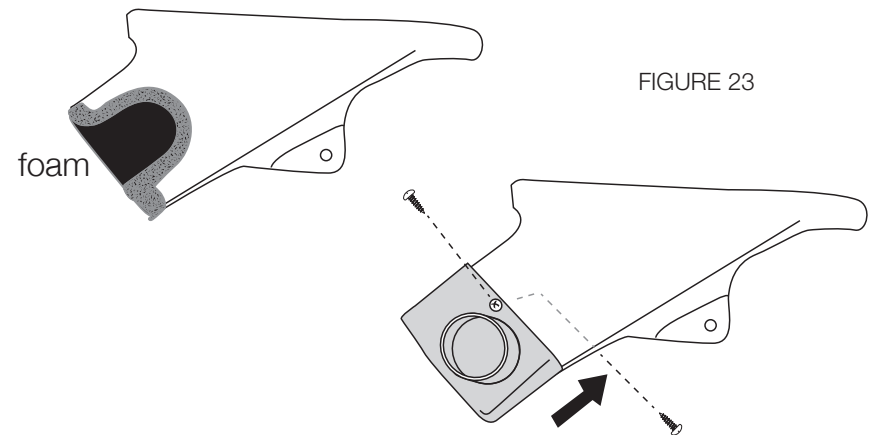

FIGURE 23

We included 2 ft. of open cell foam. Attach foam to the defrost duct as shown here. Then attach adaptor with two screws.

Locate and route the duct hoses from the defrost/heat duct assembly upward toward defrost vents. Attach the flex hose to the defrost defuser using zip-ties. The other end of the duct hose is installed over the defrost/heat duct assembly outlets on main unit (see figure 24).

The defrost duct hoses can now be routed upward and attached to the adapters using the included zip-ties.

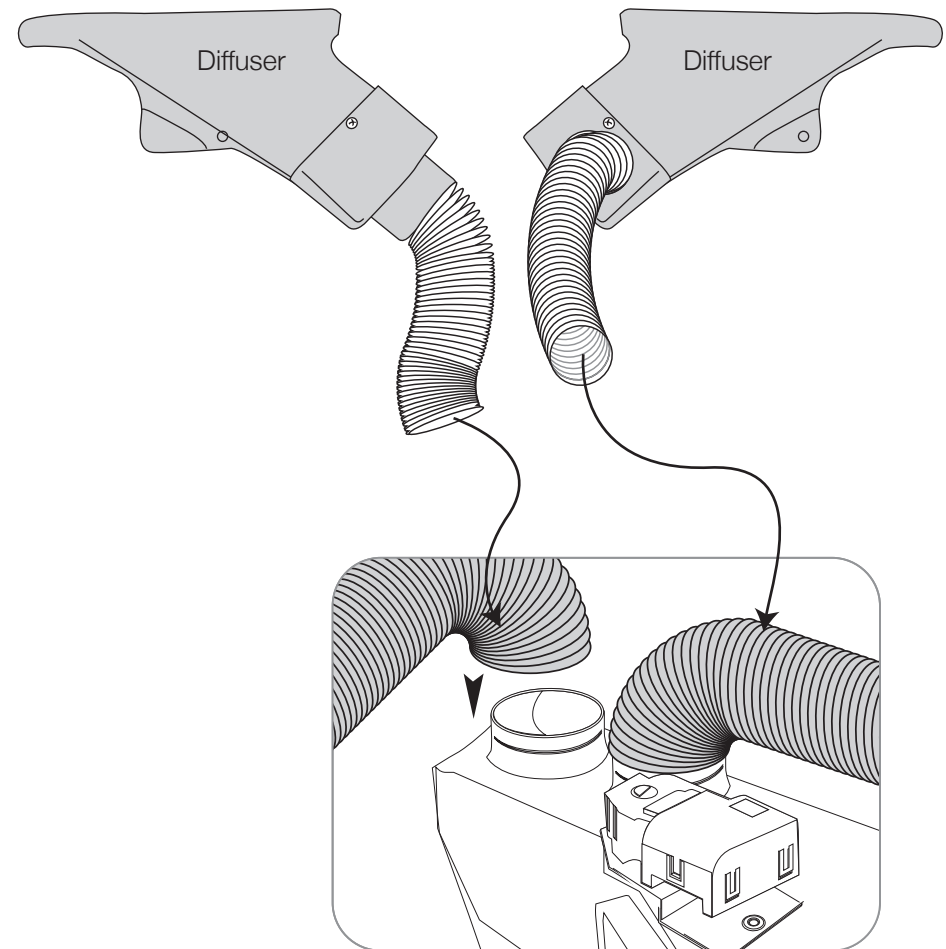

FIGURE 24

In order to install the center louvers you'll need to cut out the center upper block off (this space is used for vents on factory air cars). Carefully cut entire center out of the frame, using the vents we've included to test for size. It's best to cut a bit small first, then enlarge slowly (like with a file) until you can get a tight and secure fit for the vents (see figure 25).



The smoother the route of the flex hoses the better the airflow.

Insert the new center louver assembly. We've included a bracket to secure the louver to the dash with two #6 x 3/8" screws. Attach the bracket to the backside of the vent assembly and securely tighten from the backside (see figure 26).

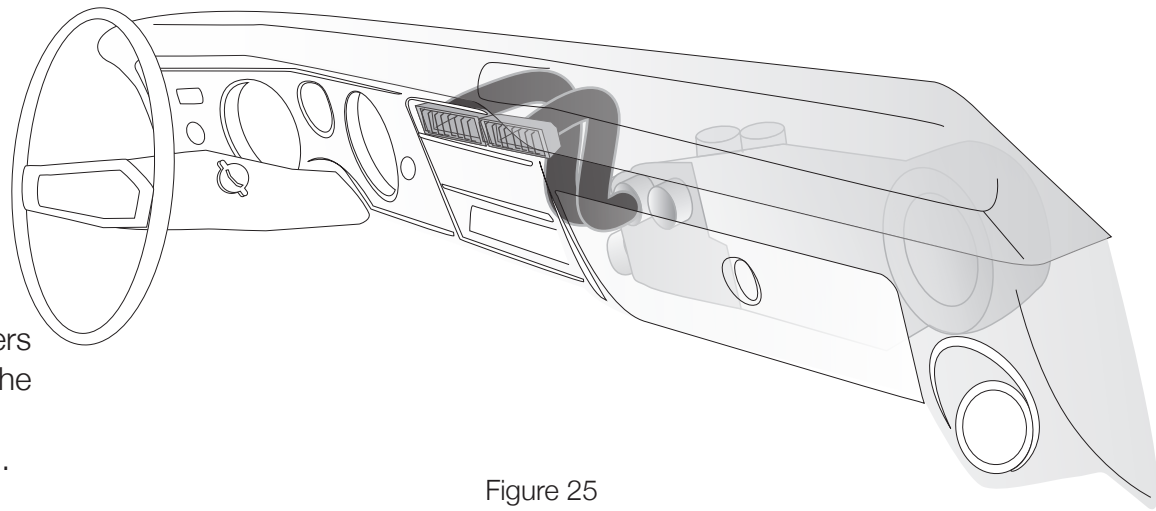

Attach duct hoses to the back of the louvers assembly with tywraps and then route to the evaporator. Take your time and route them so they don't become kinked or torn.

During installation of the hoses be aware of the eventual movement of the wiper arm components.

Figure 25

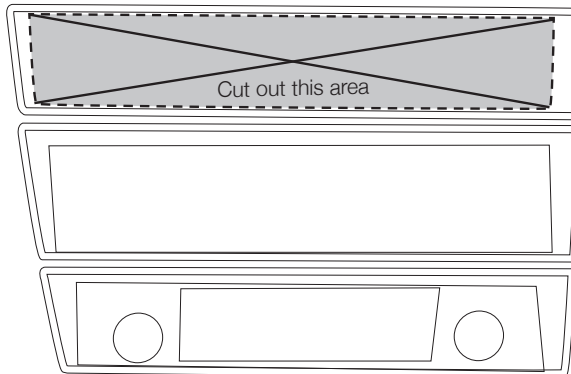
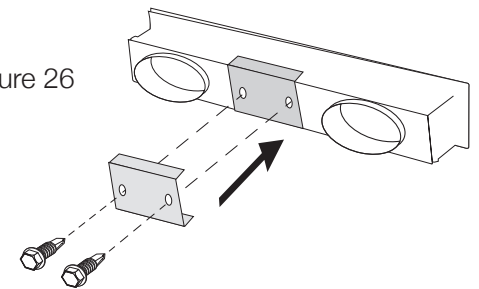

Figure 26



Bag Kit F: The face/floor assembly comes preinstalled with s-clips which allow you to install it onto the evaporator unit quickly and securely (see figure 27).

Attach lower dash louver adaptors to the bottom of the dash using the included tek screws. Positions the vents so that they won't interfere with any components and so that the driver and passenger will get the best use of the airflow.

Route supplied flex hoses as shown below. Take your time and route them so they don't become kinked or torn. Hoses are secured to the back of the louvers

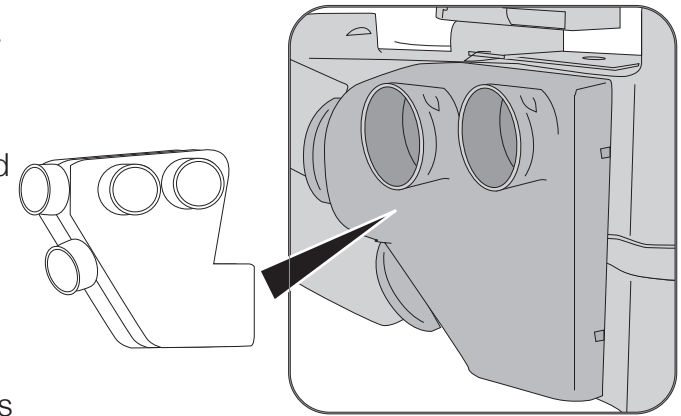
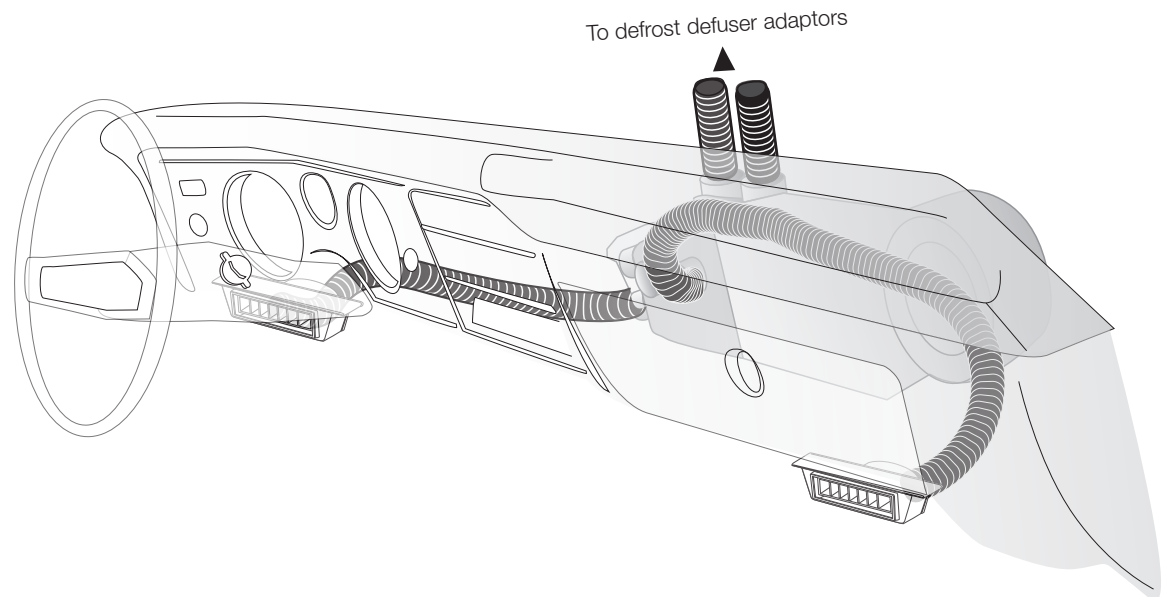
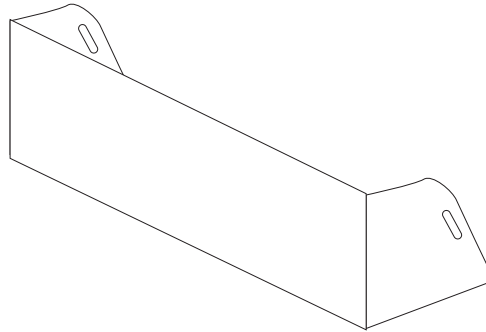

FIGURE 27



The smoother the route of the flex hoses the better the airflow.





We've included a replacement glovebox that you can install at this point. We've included screws, and you'll attach the new glovebox to the OEM glovebox door.

This completes the interior portion of the **PERFECT FIT-ELITE** installation process. This is a good time to make a final check that all the controls still move freely and that nothing is loose or hanging down.

The interior of your car should look pretty much the same as before you started (or better). Plus you probably got to know the underside of your dash a lot better and might even have repaired or upgraded components that needed attention.

If you have any questions before you move on the final phase of this installation, call us.

Good Job... Let's move on to the major components within the engine compartment....

THESE ARE THE PARTS YOU WILL NEED FOR THE ENGINE COMPARTMENT INSTALLATION ON A SMALL BLOCK 1968 CHEVELLE

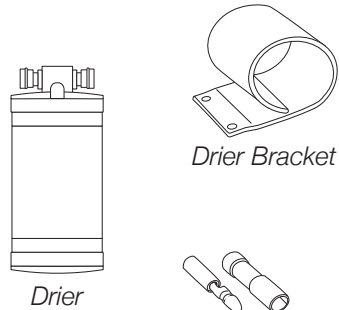

Drier Bracket

Drier



Splice and Bullet Connector

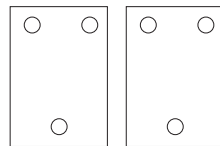

Two Condenser Brackets
PN#031-8

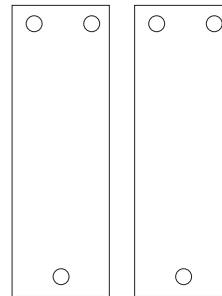

Two Condenser Brackets
PN#031-9

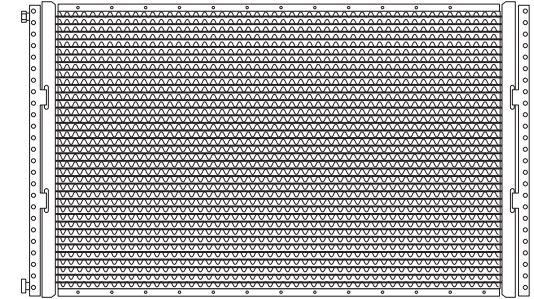

Condenser
PN#11-1041



Ten #10 - 20x3/8" Screws

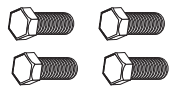

Four #1/4 x 5/8" Bolts

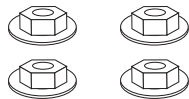

Four #1/4 Flange Nuts



Two Bulkhead Grommets

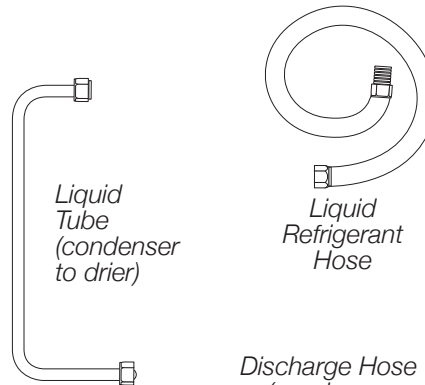

Liquid Tube
(condenser to drier)

Liquid Refrigerant Hose

Discharge Hose
(condenser to rad support)

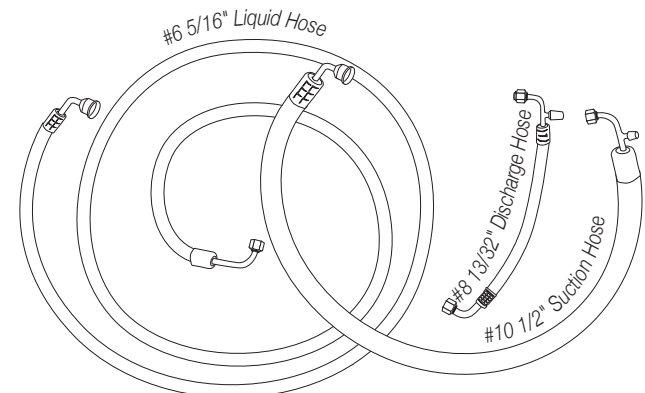
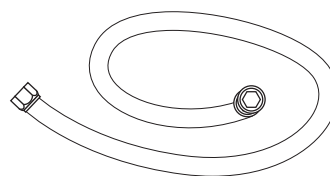

Three Refrigerant Hoses

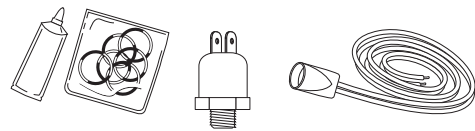

Pressure Switch and harness,
Bag of O-rings and Mineral Oil Tube

THESE ARE THE PARTS YOU WILL NEED FOR THE ENGINE COMPARTMENT INSTALLATION ON A BIG BLOCK 1968 CHEVELLE

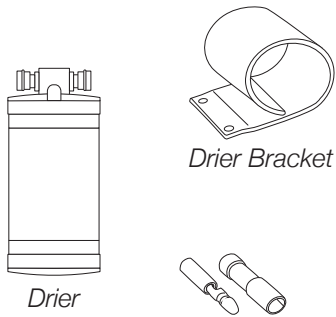

Drier Bracket

Drier

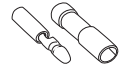

Splice and Bullet Connector

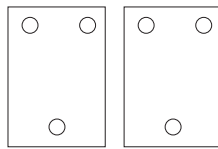

Two Condenser Brackets
PN#031-8

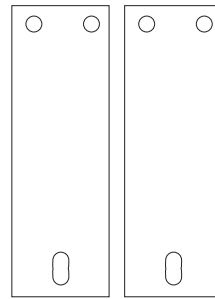

Two Condenser Brackets
PN#045-4

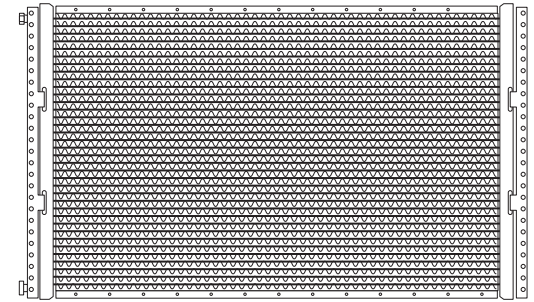

Condenser
PN#11-1041



Ten #10 - 20x3/8" Screws

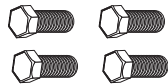

Four #1/4 x 5/8" Bolts

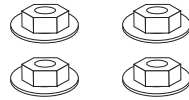

Four #1/4 Flange Nuts

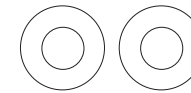

Two Bulkhead Grommets

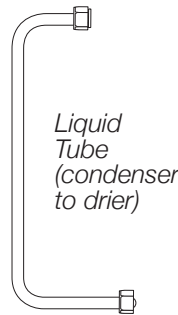

Liquid Tube
(condenser to drier)

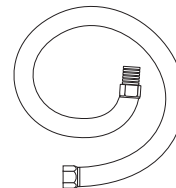

Liquid Refrigerant Hose

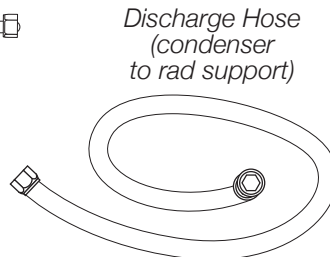

Discharge Hose
(condenser to rad support)

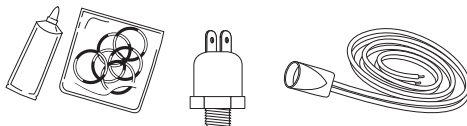

Pressure Switch and harness,
Bag of O-rings and Mineral Oil Tube

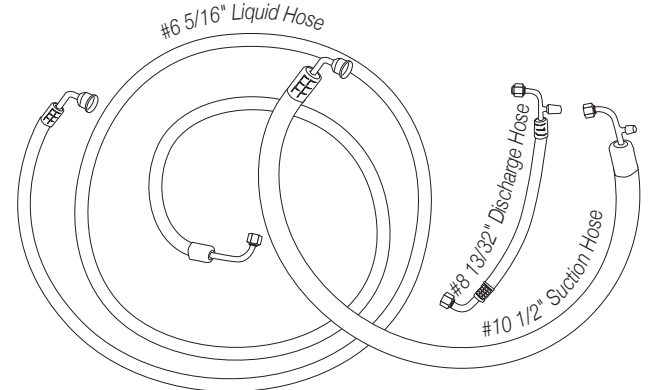

Three Refrigerant Hoses

DRIER AND CONDENSER PREPARATION. You can perform most of the following steps on a clean flat surface like a workbench. Lay the condenser down so that both hose connections are on the left side (the larger connection will be on top). The drier is conveniently mounted on the left hand side of the condenser. First insert the drier into the drier mounting bracket. Attach the drier liquid tube to the drier and also to the connection on the condenser (tighten connections at either end using supplied o-rings on both ends and a few drops of mineral oil to each o-ring). With these two combined it will easy to find the correct place to attach the drier bracket to the condenser with the included #10-20 x 1/4" screws (attach drier and bracket from the front of the condenser).

BRACKETS: Install the upper condenser brackets using four #10 - 20 x 3/8" screws as shown in figure 28. Next, attach the lower brackets in the positions shown in figure 29.

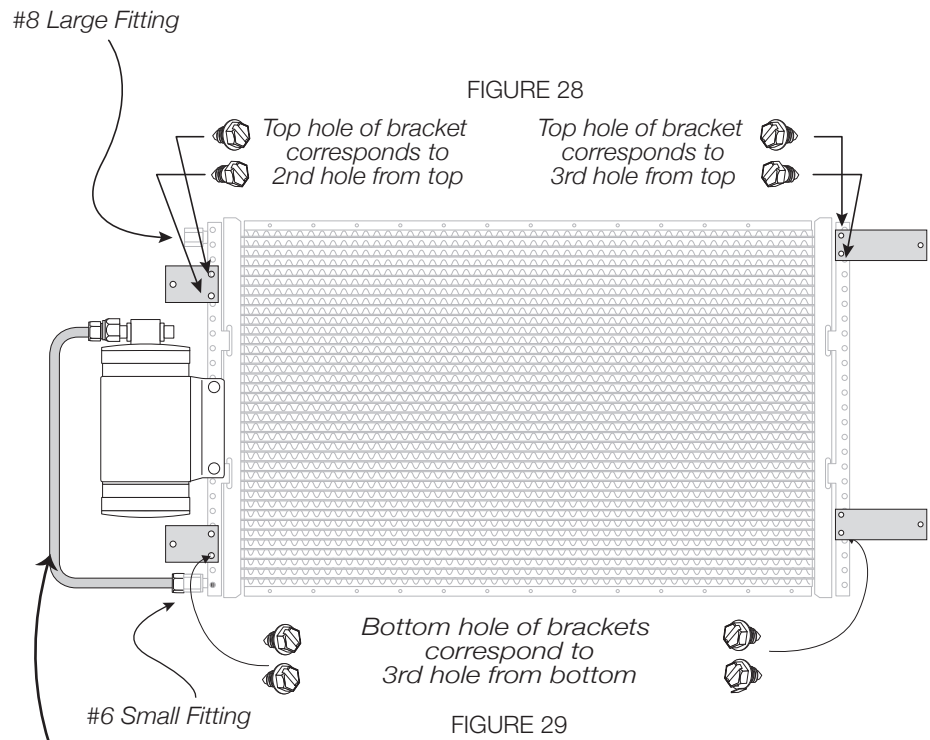

You can easily find the correct position for mounting the drier to the condenser by using the drier liquid tube as a gauge.

For the next series of steps you may need to remove the battery. Carefully place the entire condenser assembly through the radiator bulkhead and position into it's final place. Match drill holes thru the condenser support brackets using a 9/32" drill bit, then fasten loosely with included tek screws.

FIGURE 30

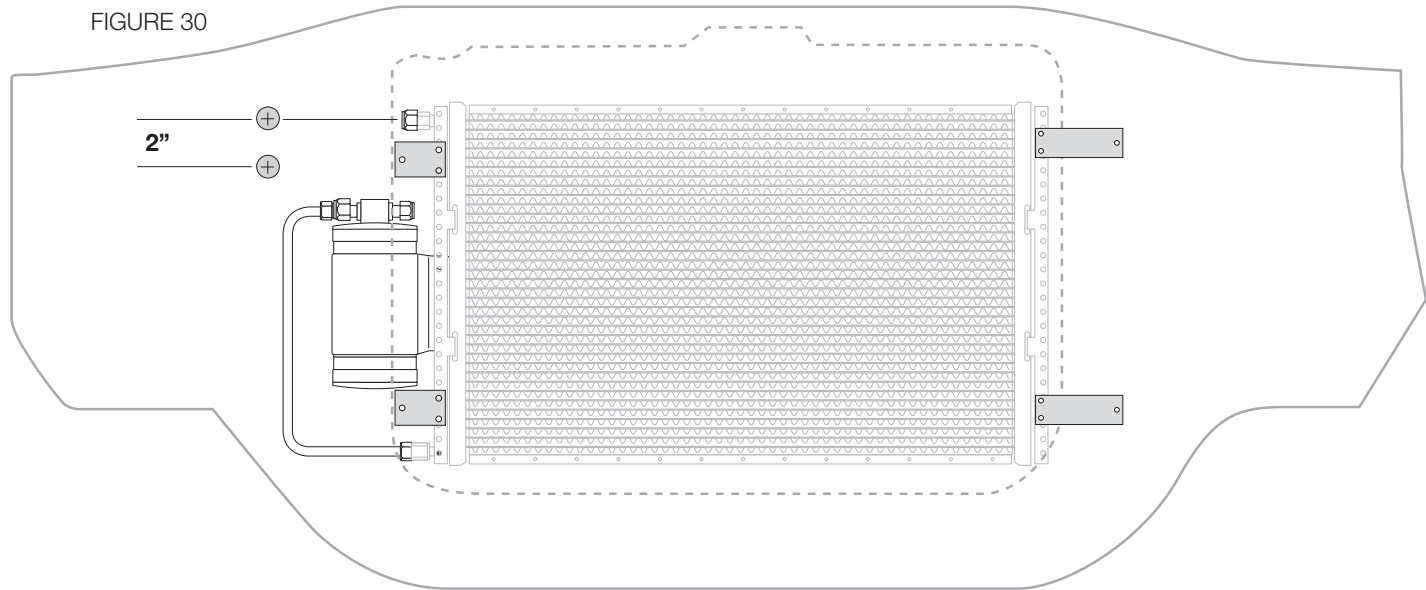

Locate and drill a 1-1/2" hole through the support directly inline with the upper refrigerant fitting on the condenser. The #8 hose will go this hole, you can use the hose as a guide before you drill also. **THE LOCATION OF THIS HOLE IS IMPORTANT, SO DOUBLE CHECK BEFORE DRILLING.** After drilling, place an included grommet into holes (see figure 30).

Next, drill another 1-1/2" hole approximately 2" below the first hole. Install grommet into this hole also.

Use the four 5/8" hex bolts and 1/4 flange nuts we've included and install them thru the condenser brackets and into the radiator support holes you've already drilled.

Locate the liquid bulkhead tube and one #6 o-ring. Attach liquid tube to the drier using one #6 o-ring and few drops of lubricating oil and a 3/4" open end wrench. Route thru upper hole you drilled in the support. Next do the same thing for the #8 refrigerant hose, attaching it to the upper fitting on the condenser and routing thru the lower hole you drilled.

hi/low pressure switch
FIGURE 31

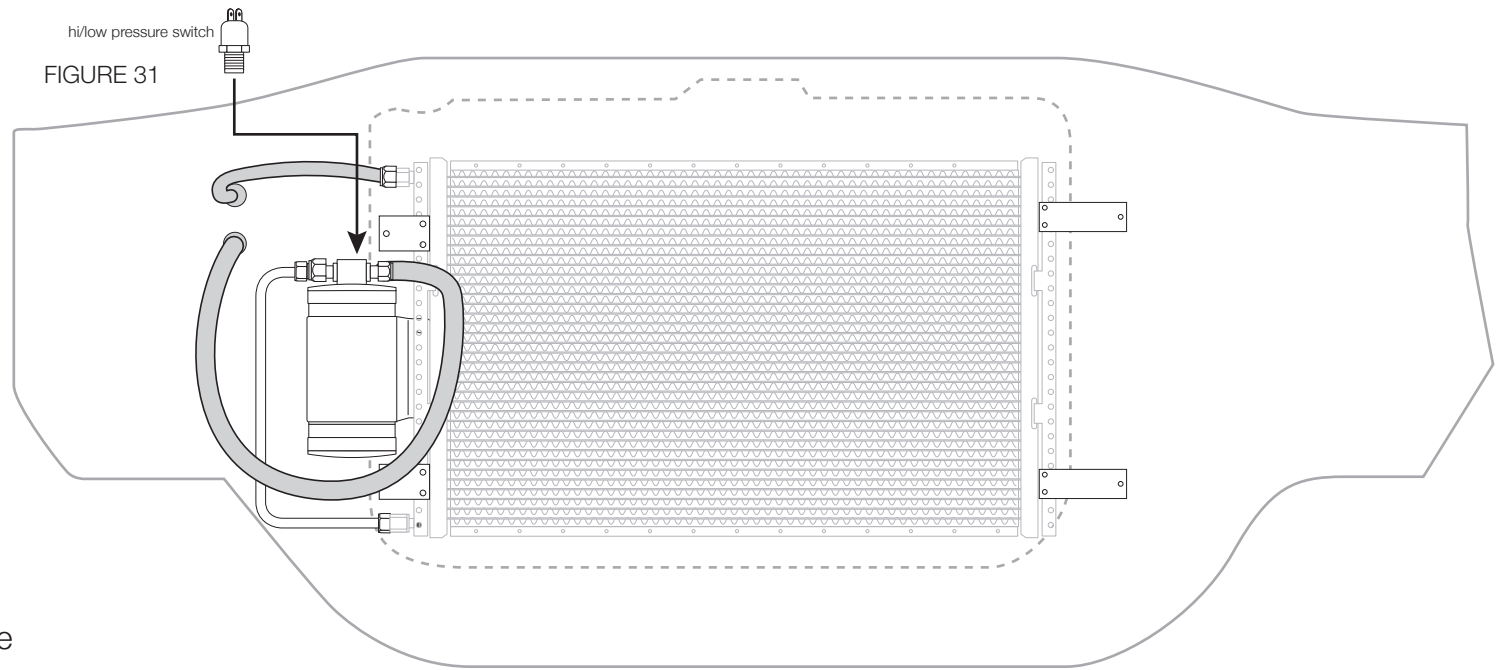

PRESSURE SWITCH: Screw the high-pressure switch into the port on the top of the drier (see figure 31). Go ahead and plug the pressure switch harness into the switch at this time (black electrical boot with two long white wires).

Route the two white wires through the grommet along with #6 refrigerant hose. One of the wires attaches to blue clutch wire from thermostat and the other to the compressor clutch.



Reminder...
Use two
wrenches to
tighten o-ring
fittings

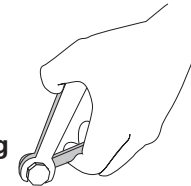

Time to install the compressor kit. Included was a premium compressor kit with all the parts you'll need to install the compressor. This kit includes instructions specifically written for your engine. Once you've installed the complete compressor kit, continue on to connecting the hoses.

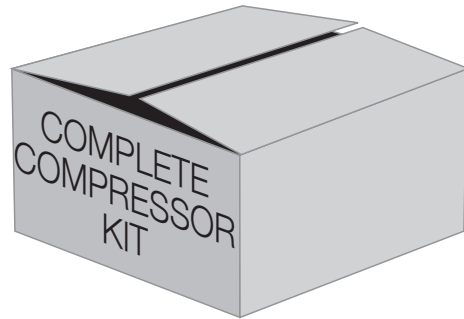

CONNECTING THE HOSES:

- 1) Attach the #8 Discharge Hose (13/32") from the connection coming thru the support and route to the compressor. Tighten fittings using o-rings and mineral oil provided.
- 2) Attach the #6 liquid hose (5/16") from the connection coming thru the support and route to the connection evaporator unit (see figure 41). Tighten fittings using o-rings and mineral oil supplied in kit.
- 3) Attach the #10 suction hose (1/2") to the compressor and route as mentioned above. Tighten fittings using o-rings and mineral oil supplied in the kit.

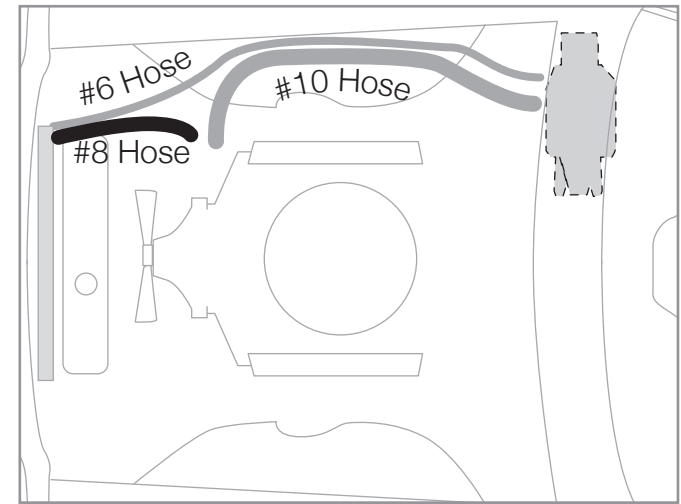

Passenger Side Compressor

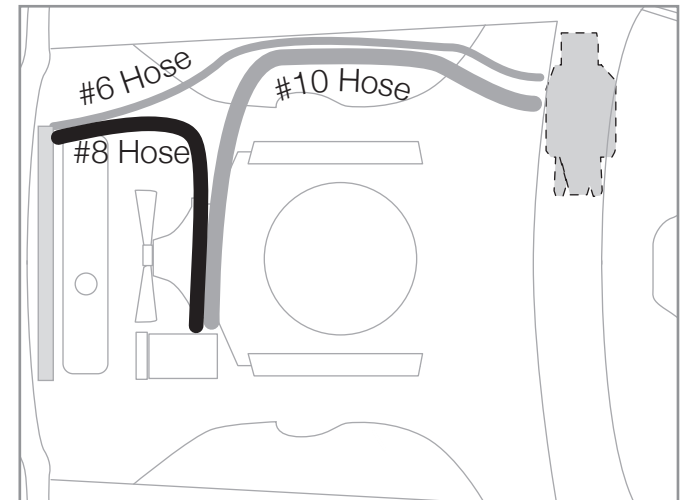

Drivers Side Compressor



FINAL STEPS: Take a look around at your installation and check all fittings and bolts for tightness, check the heater hose clamps for tightness, and make sure nothing is routed in a way to obstruct any moving parts. **You can refill the radiator and reconnect the battery at this time.**

**WAY TO GO! You've just completed the installation of your new A/C system.
The very final step is to fully charge and test your new system.**

**On the next page you'll find specifications for proper final preparation
for your A/C technician.**

New A/C System Preparation... A MUST READ!

Please read thru these procedures before completing this new A/C system charging operation.

A licensed A/C technician should be utilized for these procedures to insure that your new system will perform at it's peak, and that your compressor will not be damaged.

- 1) Your radiator/cooling system is an integral part of your new system. Please insure that you have a 50/50 mix of distilled water and antifreeze. The heater coil **MUST** be purged (cycle heater control valve) to make sure no water, without antifreeze, is in the heater coil before you charge the A/C system.
- 2) Evacuate the system for 45 minutes (minimum).
- 3) **Your new compressor MUST be hand-turned 15-20 revolutions before and after charging with liquid. Failure to do this may cause the reed valves to become damaged** (this damage is NOT covered by your warranty).
- 4) Your new system requires 134a refrigerant. It will require 1.5 lbs (or 24 oz).
- 5) Your new compressor comes charged with oil - NO additional oil is needed.
- 6) Insure that the new belt is tight.
- 7) **DO NOT CHARGE SYSTEM WITH LIQUID WHILE THE ENGINE IS RUNNING!**



RECOMMENDED TEST CONDITIONS: (After system has been fully charged and tested for basic operation)

- Determine the temperature outside of the car
- Connect gauges or service equipment to high/low charging ports
- Place blower fan switch on medium
- Close all doors and windows on vehicle
- Place shop fan directly in front of condenser
- Run engine idle up to approx. 1500 rpm

ACCEPTABLE OPERATING PRESSURE RANGES:

1. HIGH-SIDE PRESSURES (150-250 PSI)
2. LOW-SIDE PRESSURES (15-25 PSI in a steady state)

Readings above are based on an ambient temperature of 90° with an adequate airflow on condenser

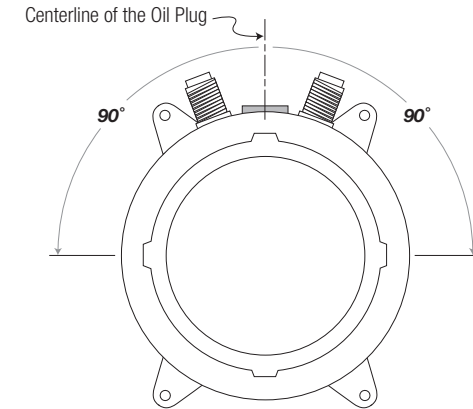

CAUTION! When mounting your compressor and/or adjusting the belt, use caution not to tilt the compressor up to or more than 90° off the centerline of the oil fill plug. This can cause compressor failure.

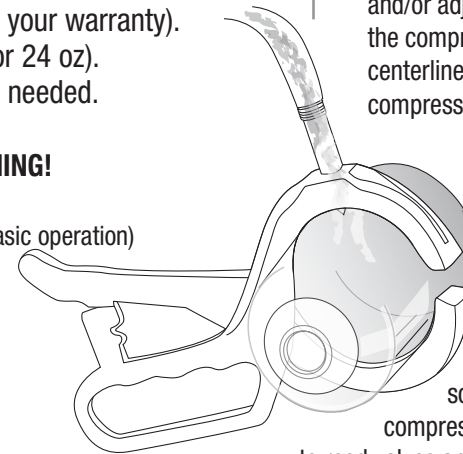

Do NOT tilt, shake or turn refrigerant can upside-down OR use a charging station to install refrigerant while the engine is running. Doing

so will direct liquid refrigerant into the compressor piston chamber, causing damage to reed valves and/or pistons and/or other components, as well as potentially seizing the compressor. Allow a minimum of 30 minutes for liquid to "boil off." You must hand turn the compressor hub (not the pulley) a minimum of 15 complete revolutions prior to starting the engine with the clutch engaged.

TROUBLESHOOTING GUIDE

TEST CONDITIONS USED TO DETERMINE SYSTEM OPERATION

(THESE TEST CONDITIONS WILL SIMULATE THE AFFECT OF DRIVING THE VEHICLE AND GIVE THE TECHNICIAN THE THREE CRITICAL READINGS THAT THEY WILL NEED TO DIAGNOSE ANY POTENTIAL PROBLEMS).

- B. CONNECT GAUGES OR SERVICE EQUIPMENT TO HIGH/LOW CHARGING PORTS.
- C. PLACE BLOWER FAN SWITCH ON MEDIUM.
- D. CLOSE ALL DOORS AND WINDOWS ON VEHICLE.
- E. PLACE SHOP FAN IN FRONT OF CONDENSER.
- F. RUN ENGINE IDLE UP TO 1500 RPM.

ACCEPTABLE OPERATING PRESSURE RANGES (R134A TYPE)

1. HIGH-SIDE PRESSURES (160-250 PSI) **Note- general rule of thumb is two times the ambient (daytime) temperature, plus 15-20%.*
2. LOW-SIDE PRESSURES (06-22 PSI in a steady state).

CHARGE AS FOLLOWS: R134A = 24 OZ.

NO ADDITIONAL OIL IS NECESSARY IN OUR NEW COMPRESSORS.

TYPICAL PROBLEMS ENCOUNTERED IN CHARGING SYSTEMS:

NOISY COMPRESSOR. A noisy compressor is generally caused by charging a compressor with liquid or overcharging

- A. If the system is overcharged both gauges will read abnormally high readings. This is causing a feedback pressure on the compressor causing it to rattle or shake from the increased cylinder head pressures. System must be evacuated and re-charged to exact weight specifications.
- B. **Heater control valve installation** - Installing the heater control valve in the incorrect hose. Usually when this occurs the system will cool at idle then start to warm up when raising the RPM's of the motor. **THE HEATER CONTROL IS A DIRECTIONAL VALVE; MAKE SURE THE WATER FLOW IS WITH THE DIRECTION OF THE ARROW.** As the engine heats up that water transfers the heat to the coil, thus overpowering the a/c coil. A leaking or faulty valve will

have a more pronounced affect on the unit's cooling ability. Installing the valve improperly (such as having the flow reversed) will also allow water to flow through, thus inhibiting cooling. Check for heat transfer by disconnecting hoses from the system completely. By running down the road with the hoses looped backed through the motor, you eliminate the possibility of heat transfer to the unit.

- C. **Evaporator freezing** - Freezing can occur both externally and internally on an evaporator core. External freeze up occurs when the coil cannot effectively displace the condensation on the outside fins and the water forms ice (the evaporator core resembles a block of solid ice), it restricts the flow of air that can pass through it, which gives the illusion of the air not functioning. The common cause of external freezing is the setting of the thermostat and the presence of high humidity in the passenger compartment. All door and window seals should be checked in the event of constant freeze-up. A thermostat is provided with all units to control the cycling of the compressor.
- D. **Internal freeze up** occurs when there is too much moisture inside the system. The symptoms of internal freeze up often surface after extended highway driving. The volume of air stays constant, but the temperature of the air gradually rises. When this freezing occurs the low side pressure will drop, eventually going into a vacuum. At this point, the system should be checked by a professional who will evacuate the system and the drier will have to be changed.
- E. **Inadequate airflow to condenser** - The condenser works best in front of the radiator with a large supply of fresh air. Abnormally high pressures will result from improper airflow. Check the airflow requirements by placing a large capacity fan in front of the condenser and running cool water over the surface. If the pressures drop significantly, this will indicate the need for better airflow.
- F. **Incorrect or inadequate condenser capacity** - Incorrect condenser capacity will cause abnormally high head pressures. A quick test that can be performed is to run cool water over the condenser while the system is operating, if the pressures decrease significantly, it is likely a airflow or capacity problem.
- G. **Expansion valve failure** - An expansion valve failure is generally caused by dirt or debris entering the system during assembly. If an expansion valve fails it will be indicated by abnormal gauge readings. A valve that is blocked will be indicated by high side that is unusually high, while the low side will be unusually low or may even go into a vacuum. A valve that is stuck open will be indicated by both the high and low pressures rising to unusually high readings, seeming to move toward equal readings on the gauges.
- H. **Restrictions in system** - A restriction in the cooling system will cause abnormal readings on the gauges. A high-side restriction (between the compressor and the drier inlet) will be indicated by the discharge gauges reading excessively high. These simple tests can be performed by a local shop and can help determine the extent of the systems problem.

Trouble Shooting Your Classic Auto Air A/C System

PROBLEM: System is not cooling properly

ISSUE: Cold at idle, warmer when raising engine RPM's

Make sure the Water Valve is positioned correctly

The water valve is a directional valve and should be installed with the arrow pointing towards the water pump, it should be connected to the heater hose that runs from the heater core to the water pump. If the water valve is connected to the incorrect hose it allows water to circulate through the system via the heater core over powering the cooling effect of the A/C coil, (normally the air conditioning is functioning properly).

Step 1: Check placement of the water valve, correct if needed. (In some cases changing the location of the water valve may not fix the above problem.) Continue to next step.

Step 2: If changing the location of the water valve does not rectify the issue, then possibly the water valve is permanently damaged and may need to be replaced. To check the integrity of the water valve completely remove the water hoses for the heater core and "loop" together. (This will remove the heater system completely from the possibilities) If the system now cools, replace the water valve

Verify Adequate Air Flow to Condenser

For an air conditioning system to function properly there has to be adequate airflow across the condenser. The function of the condenser is to dissipate heat, without proper airflow your system will not cool correctly in the cabin of your vehicle.

Step 1: Connect gauges to a/c hoses. The pressures should be: with the ambient temp is 90, low side pressures should be between 8-25 psi, high side pressures should be between 160-260psi

Step 2: If the low side pressures are normal and the high side pressures are high then there might be an airflow issue, continue to next step.

To test air flow to Condenser do the following three tests:

1. Place a piece of paper on the condenser with the car in idle and see if paper is held in place.
2. With car in idle, attach gages, and place a large capacity fan in front of the condenser. What happens to the pressures?
3. With car still in idle and gages attached, pour water down the front of the condenser. What happens to the pressures?

If the paper is held in place you are at least getting some air flow. If the high side decreases during test 2 & 3 then your condenser is not getting enough air which is causing your system to not cool properly. To correct this issue you will need a more powerful mechanical fan.

Step 3: Confirm correct Refrigerant charge in System

All of our systems should be charged with 24oz or 1.8lbs of R134 Refrigerant only. If overcharged you will need to evacuate the system and recharge with the correct amount.*

What measurements mean:

- Low Temp and High Pressure seem to be equal...

You have a malfunctioning expansion valve that is stuck open.

- High Side is extremely high and Low Side is extremely low (possibly into vacuum)...

There is a blockage in the system. Remove hoses and blow compressed air through in both directions. If pressures don't change its possible that your expansion valve is stuck closed and would have to be replaced.

***Compressor Concerns:**

This is often misdiagnosed as a problem for the system not cooling properly. If you have a noisy compressor it is due to improper charging of refrigerant. An overcharged (more than 24oz or 1.8lbs R134) compressor can cause rattling. If charged with pure liquid there is a high probability you have bent the reed valves and they are causing tapping sound.

ALIGN WITH EDGE OF DEFROST DUCT

Template Right Side Defrost
1968 Chevelle

CUT EDGE



**IF YOU PRINTED THIS MANUAL
PLEASE READ THIS...**

Just as a cautionary step, please measure this box and make sure it is 1" x 1". Some copiers/printers may not print at 100% of actual size.

ALIGN WITH TOP OF DEFROST DUCT

ALIGN WITH HOLE



Template LEFT Side Defrost
1968 Chevelle

CUT LINE

**IF YOU PRINTED THIS MANUAL
PLEASE READ THIS...**
Just as a cautionary step, please
measure this box and make sure it
is 1" x 1". Some copiers/printers
may not print at 100% of actual size.

