

# ***Installation Manual***

---

## ***1967 Camaro/Firebird***

DOCUMENT #1-2054

©2012 ClassicAutoAir / 3.12vs.a





# ***Congratulations...***

**You have just purchased the highest quality, best performing A/C system ever designed for your Classic Vehicle.**

To obtain the high level of performance and dependability our systems are known for, please pay close attention to the following instructions. Our installation steps and procedures are derived from a long history of research and development and the combined experience achieved thru thousands of successful installations (and feedback from customers like you). Please remember that our #1 goal is that you'll have a successful installation and a system that performs at a very high level for many years to come.

Before starting, read the instructions carefully, from beginning to end, and follow the proper sequence. On the next page you'll find a safety and general checklist that you should read before starting your installation.

Again, thank you from our entire staff.



## Check List, Pre-Installation:

- Before beginning the installation check the shipping box for the correct components. YOUR BOXED UNIT INCLUDES A LIST OF MAJOR COMPONENTS AND A LIST OF BAGGED PARTS. We have a 5 stage check process to make sure you have everything you'll need.
- If your vehicle has been or is being modified, some procedures will need to be adjusted to fit your particular application.**
- A basic cleaning of the engine compartment and interior before beginning will make things go more smoothly.
- Check condition of engine mounts. Excessive engine movement can damage hoses to A/C and/or heater.
- Before starting, check vehicle interior electrical functions (interior lights, radio, horn, etc). Make a note of anything that does not work as it's supposed to. During the installation you might find the opportunity to repair or upgrade non-working or out of date components. When you're ready to start the installation, **DISCONNECT THE BATTERY FIRST.**
- Drain the radiator. Retain the coolant and reuse, or dispose of properly.
- SAFETY FIRST: Wear eye protection while drilling/cutting, deburr sharp edges, and never get in a hurry or force a part.
- Tools: Your installation only requires the basic tools everyone has in their garage, nothing exotic or specific to A/C or Heat equipment.

## Procedures, During Installation:

- Fittings: Use one or two drops of mineral oil (supplied with your kit) on ALL rubber o-rings, threads and rear of bump for o-ring where female nut rides. Do not use thread tape or sealants.
- Measure twice (or more), cut once
- Should you have any technical questions, or feel you have defective components (or missing items), call us immediately, we will be glad to assist you. Our toll-free number is listed on every page, we're here to help!**

***YOU CAN NOW BEGIN THE INSTALLATION...***

## A Basic A/C Overview

- 1 Evaporator with Blower Fan** In order to remove the heat from the air in the vehicle, the A/C evaporator allows the refrigerant to absorb the heat from the air passing over it. The blower fan moves cool air out into the car interior.
- 2 Compressor** The compressor pumps and circulates the refrigerant through the system.
- 3 Condenser** The condenser is a heat exchanger mounted at the front of the vehicle. Heat drawn out of the interior of the car is expelled here.
- 4 Receiver/Drier** The drier not only dries refrigerant, it also filters the refrigerant and stores it under certain operating conditions.
- 5 High Pressure Switch** A pressure switch is used to shut down the system if high or low pressure is detected, basically it acts as a safety switch.

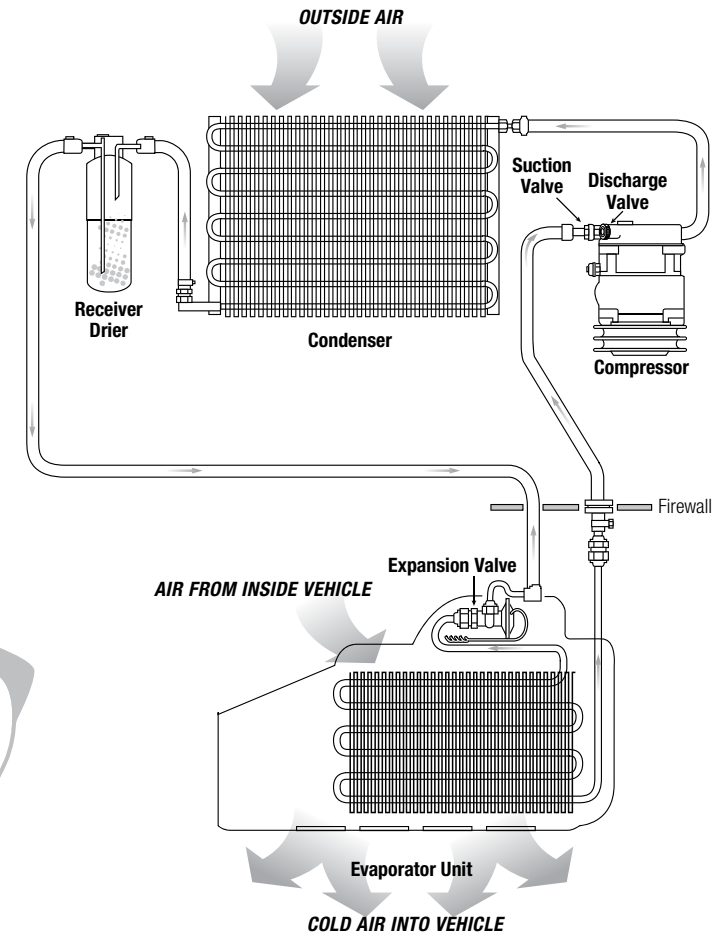
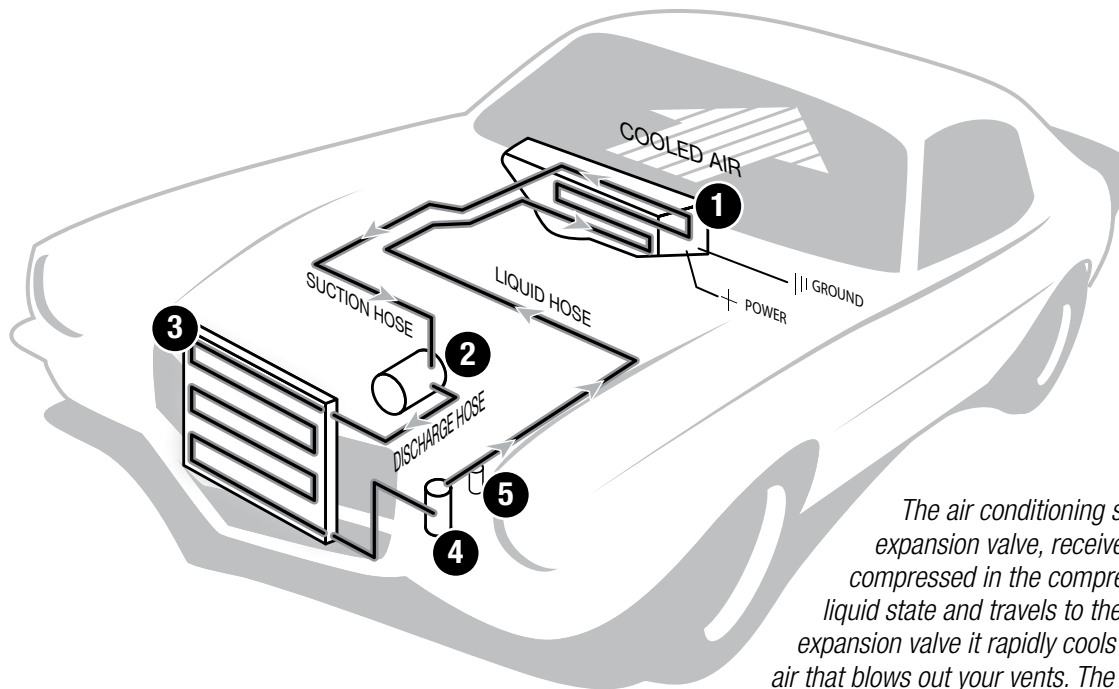

The air conditioning system in your car is comprised of a compressor, condenser, expansion valve, receiver/drier, and evaporator. Refrigerant (also known as Freon) is compressed in the compressor and turns into a gas. In the condenser, this gas is cooled to a liquid state and travels to the expansion valve. As the liquid refrigerant goes through the expansion valve it rapidly cools in the evaporator. A fan blows over the evaporator and cools the air that blows out your vents. The receiver-drier separates gas and liquid.



# Control & Operating Instructions

Your new **Perfect Fit-Elite** system offers complete comfort capabilities in virtually every driving condition. This includes temperature control in all of the modes. This system also provides the ability to blend the air between Face, Heat, and Defrost modes simultaneously. To illustrate the various ways you can adjust the airflow direction and temperature - we've provided these handy illustrations and chart to show exactly how you can adjust your **Perfect Fit-Elite** for maximum comfort...

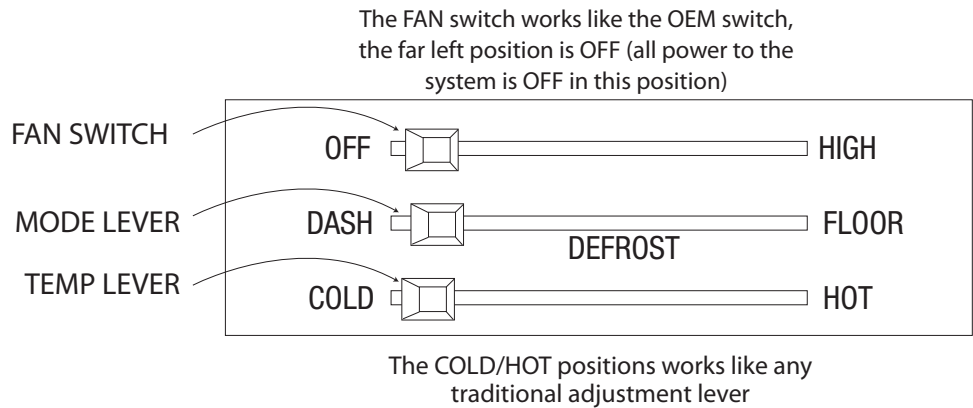

There are 11 levels of adjustment within the range of the DASH/FLOOR lever

	DASH					DEF					FLOOR
Left Lever Position	1	2	3	4	5	6	7	8	9	10	11
Distribution	Face A/C 100%	Face A/C 80%	Face A/C 60%	Face A/C 40%	Face A/C 20%	Defrost 100%	Floor 20%	Floor 60%	Floor 40%	Floor 80%	Floor 100%
		Defrost 20%	Defrost 40%	Defrost 60%	Defrost 80%		Defrost 80%	Defrost 40%	Defrost 60%	Defrost 20%	
Compressor State	ON					ON					



Remove Glovebox, Console (optional) Radio and Bezel, and set them aside for reinstall later (see figure 1).

The removal of the Original Heater Assembly can be accomplished by disconnecting three control cables. One is attached to the Heat/Defrost door (see figure 2). One is attached to the Temperature door, and one is attached to the Vent / Heat door (see figure 3). Disconnect the electrical harness from the assembly. Also remove attachment screw located in front of the air inlet (see figure 4).

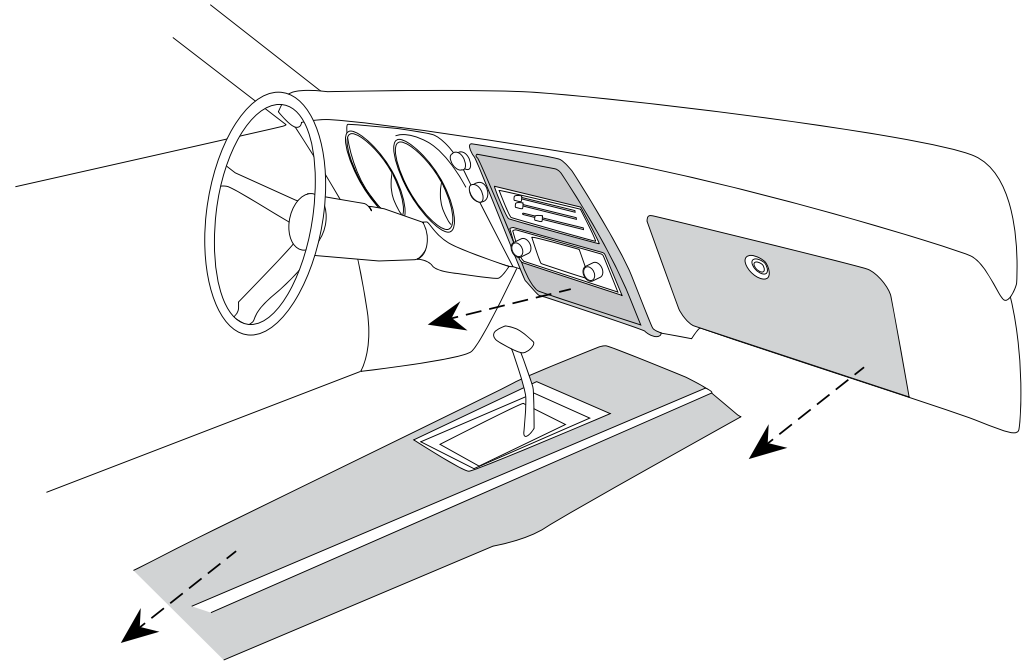

When retaining parts it's a good idea to store parts in a zip lock bag, labeled with info where the parts came from and what size/type of tool is needed to reinstall. Cleaning the parts before you need to reinstall them is a good idea too.

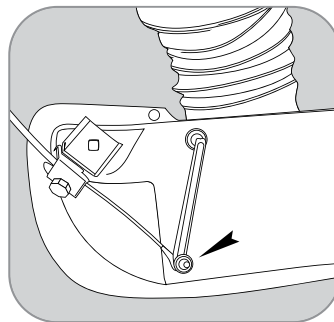

FIGURE 2

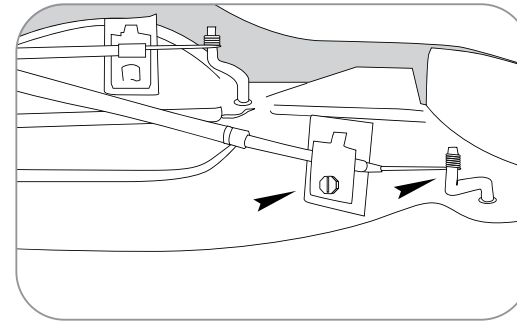

FIGURE 3

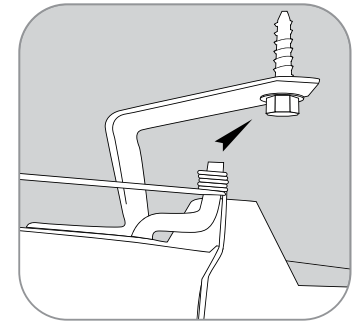
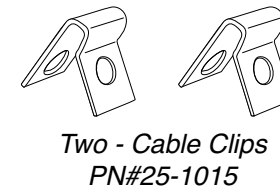
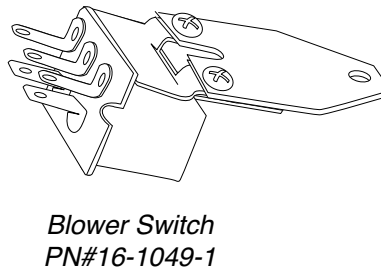
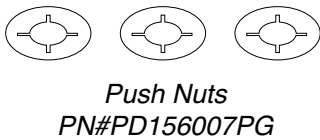
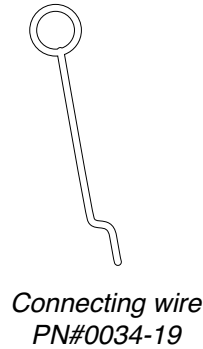
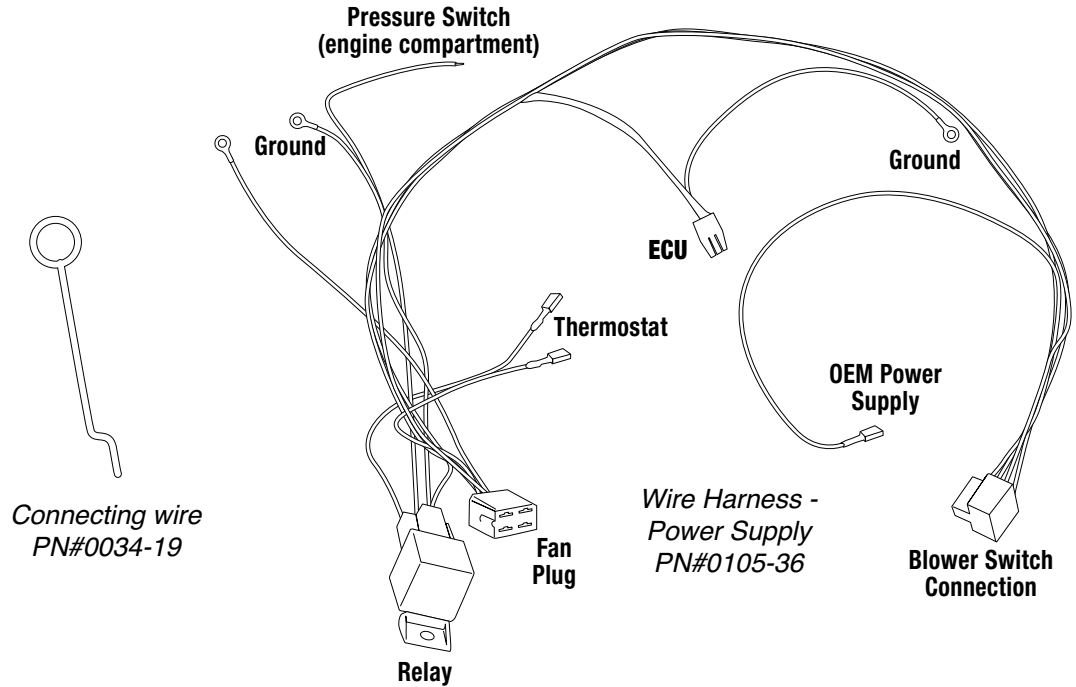
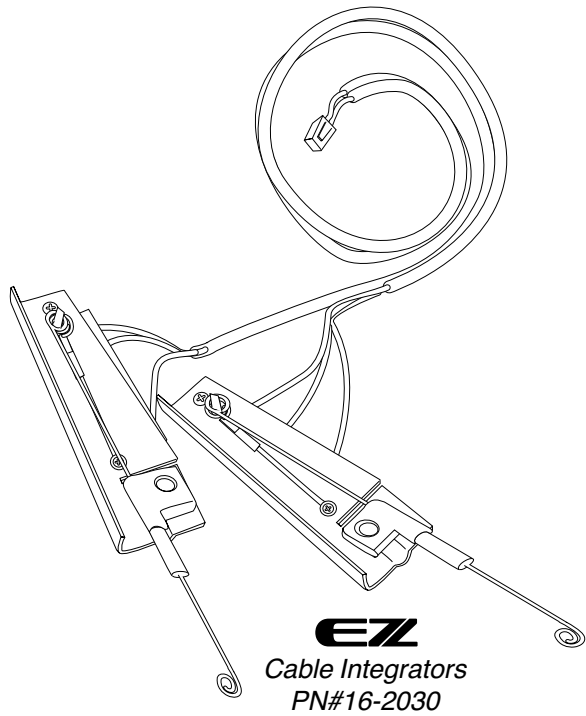

FIGURE 4

# THESE ARE THE PARTS YOU WILL FIND IN BAG KIT A

You will use all of these parts and hardware during the next series of installation steps.



NOTE: Illustrations NOT shown actual size

### Remove The Heater Control Head From The Dash.

- 1) Remove the OEM blower switch knob. Retain the screws, you will use them again shortly. Remove the control cables and the original blower switch and set aside (these will not be reused).
- 2) Attach the new blower switch with bracket as shown to the right, utilizing the OEM screws.
- 3) Attach the included connecting wire to one end of the control switch arm (it will “jog” thru the hole) and the other end will be secured to the control arm pin with a push nut.

This completes this side of the control modification.

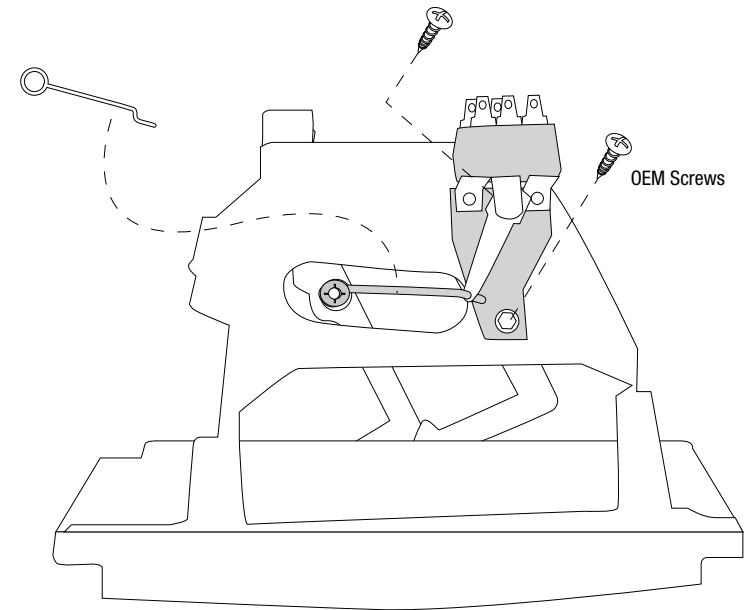

**Flip the control head over and continue on...**

**Preparing the EZ Cable Integrators for installation:** First place the included cable clips over the ends of the EZ Integrators (as shown in figure 5). Prepare both integrators the same way.

Next, attach the EZ Cable Integrators to the control head as show in figure 12. One will be attached to the body (utilizing an OEM screw that held a cable), the other to the lower control body extension, also using an OEM screw. The loop ends of the integrators will be secured with the two remaining push nuts.

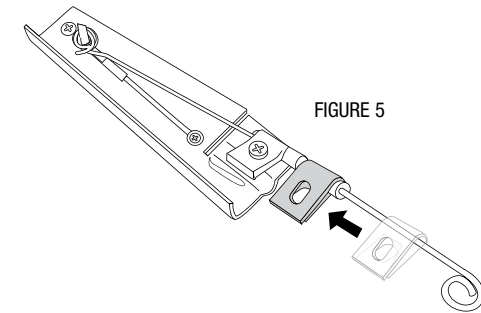
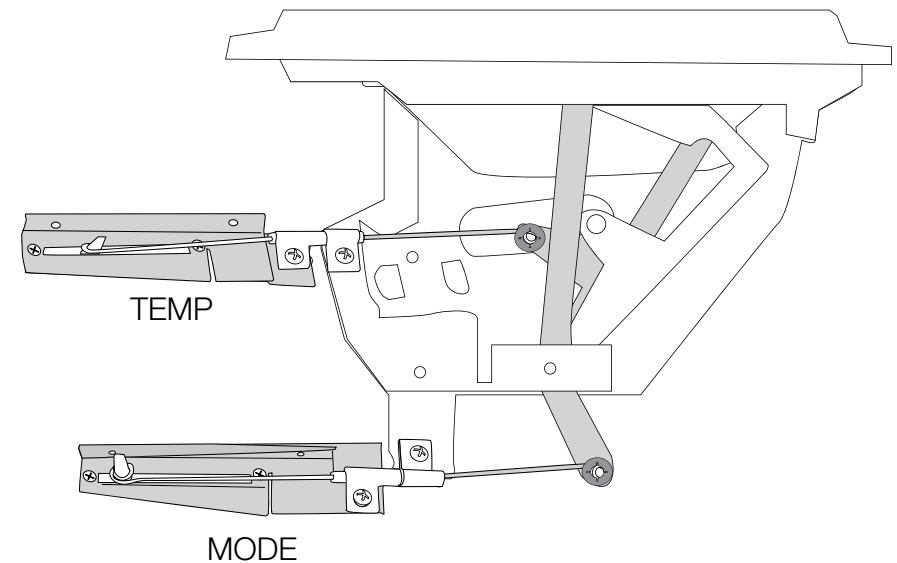
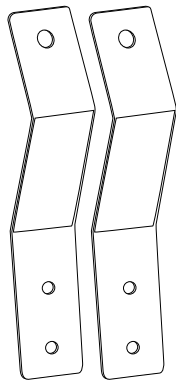

FIGURE 5



# THESE ARE THE PARTS YOU WILL FIND IN BAG KIT B

You will use all of these parts and hardware during the next series of installation steps.



Evaporator Support Brackets  
PN#0023-7

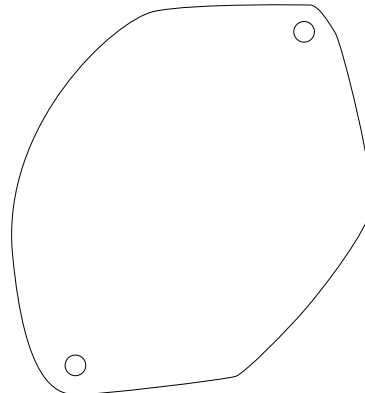

Fresh Air Inlet Block Off  
PN#10-1048-2

Liquid Tube  
PN#0034-9

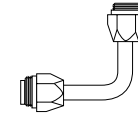

Suction Tube  
PN#0034-10



#6 and #10 O-ring

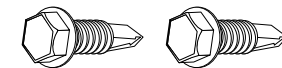

Two #10 - 16 x 3/4" Tek Screws

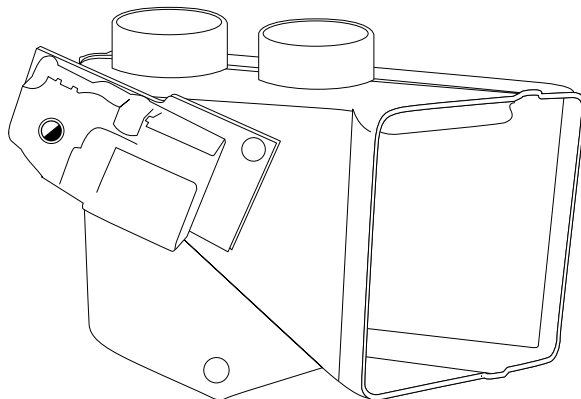

Defrost/Heat Duct Assembly  
PN#2-2025-2



One Bulb Clamp

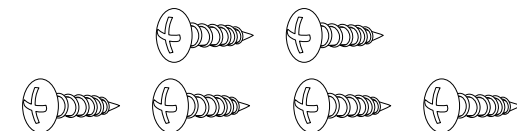

Six #10 - 10 x 5/8" Phillips Screws



One Male Spade Connector

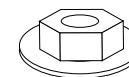

One Flange Nut

Illustrations NOT shown actual size

Locate the original wiring harness that supplied power to the original heater motor. Reaching thru the glove box opening pull these wires out of their grommet (see figure 6). (GM normally used a brown wire for power). On the OEM power supply wire attach a 1/4" insulated male spade connector. Within the OEM fuse box upgrade the factory HEATER fuse with a 20 amp fuse (**VERY IMPORTANT**).

Looking thru the glove box door opening, locate the bottom left mounting hole in the firewall that attached the original heater motor, and follow the directions for drilling as shown below. From inside of the vehicle drill a 5/8" dia. hole for the drain tube.

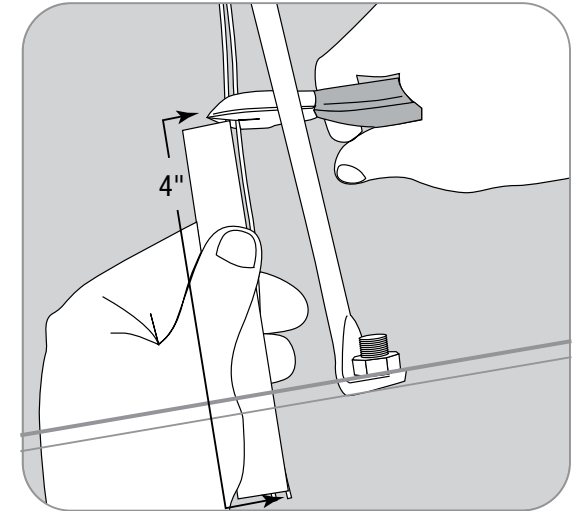
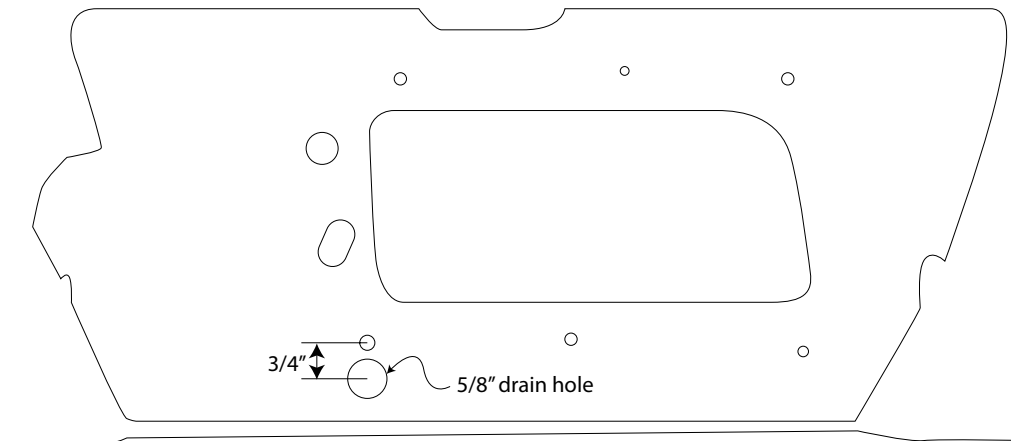

FIGURE 6

**THIS IS  
FROM THE INSIDE  
OF THE VEHICLE!**



***You can now begin installing your Classic Air Perfect Fit Elite System.***

Within the engine compartment area, Install a Fresh Air inlet block off over the OEM vent opening using the original bolts.

Remove evaporator unit from box and place on a flat work surface.

Locate defrost / heat duct assembly and attach to the evaporator using two #10 - 10 x 5/8" Phillips screws (see figure 7). NOTE: Be sure that the s-clips are pushed over rear flange on evaporator.

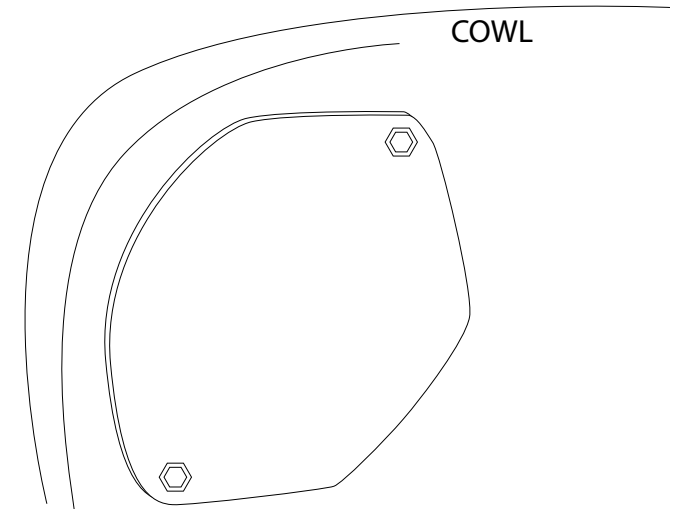

***Take a minute to familiarize yourself with the evaporator unit:***

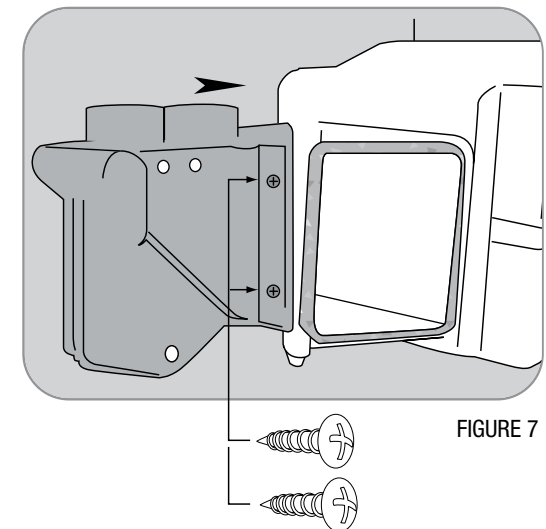
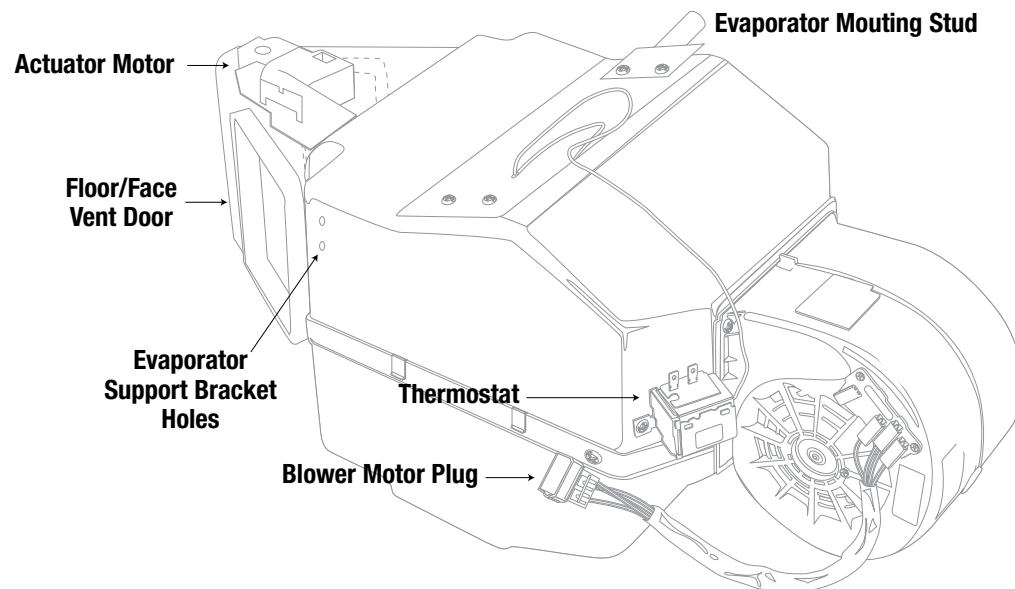

Installing the complete evaporator unit under the dash will go much easier with the help of a friend. One person can take the unit within the car and “roll” up and under the dash while the other person can be ready at the firewall area with the included flange nut to secure the unit in place (see figure 8). Now the unit will be easy to level and secure. Leveling the unit is very important to insure proper drainage of condensation.

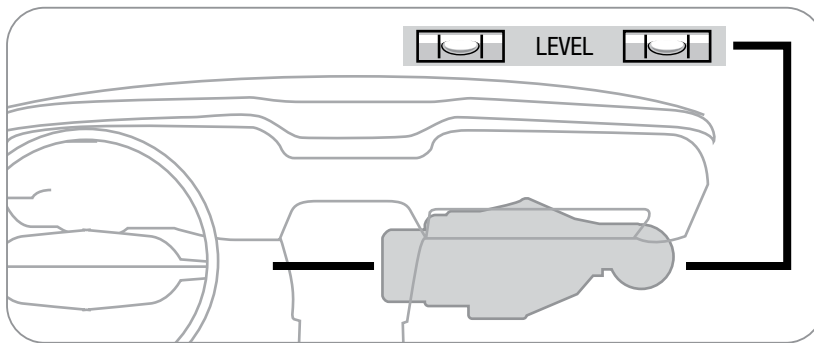

Be sure to align the evaporator unit level with the bottom of instrument panel (assuming the vehicle is sitting level) as shown above, but with a small degree of tilt toward the back to allow proper drain of condensation.

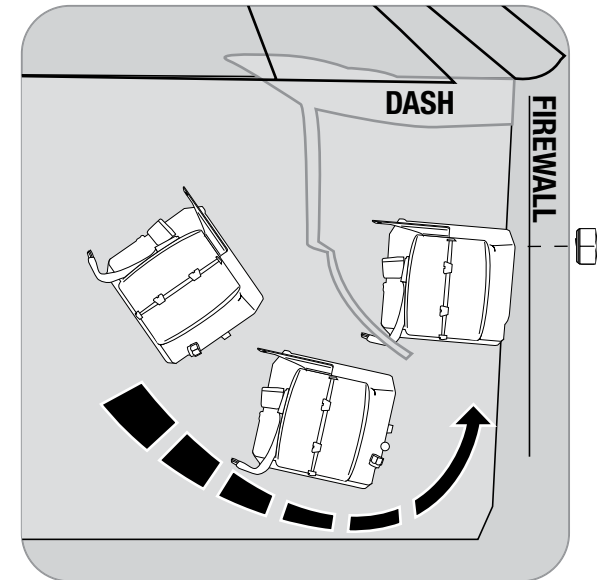

Flange Nut attached to stud protruding thru original mounting hole

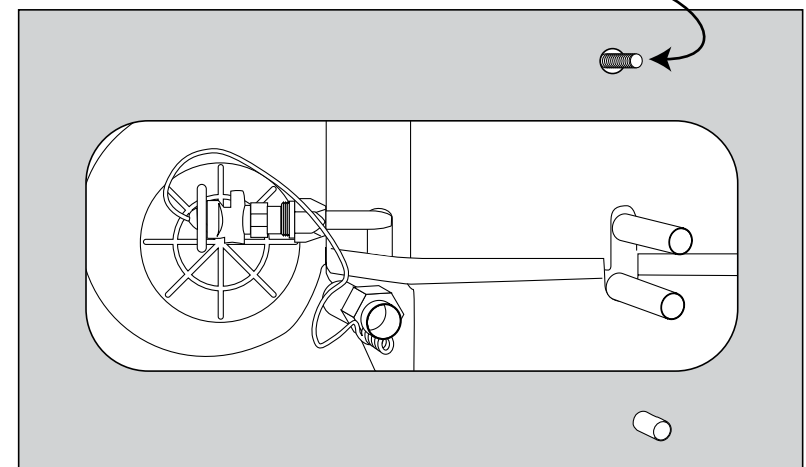
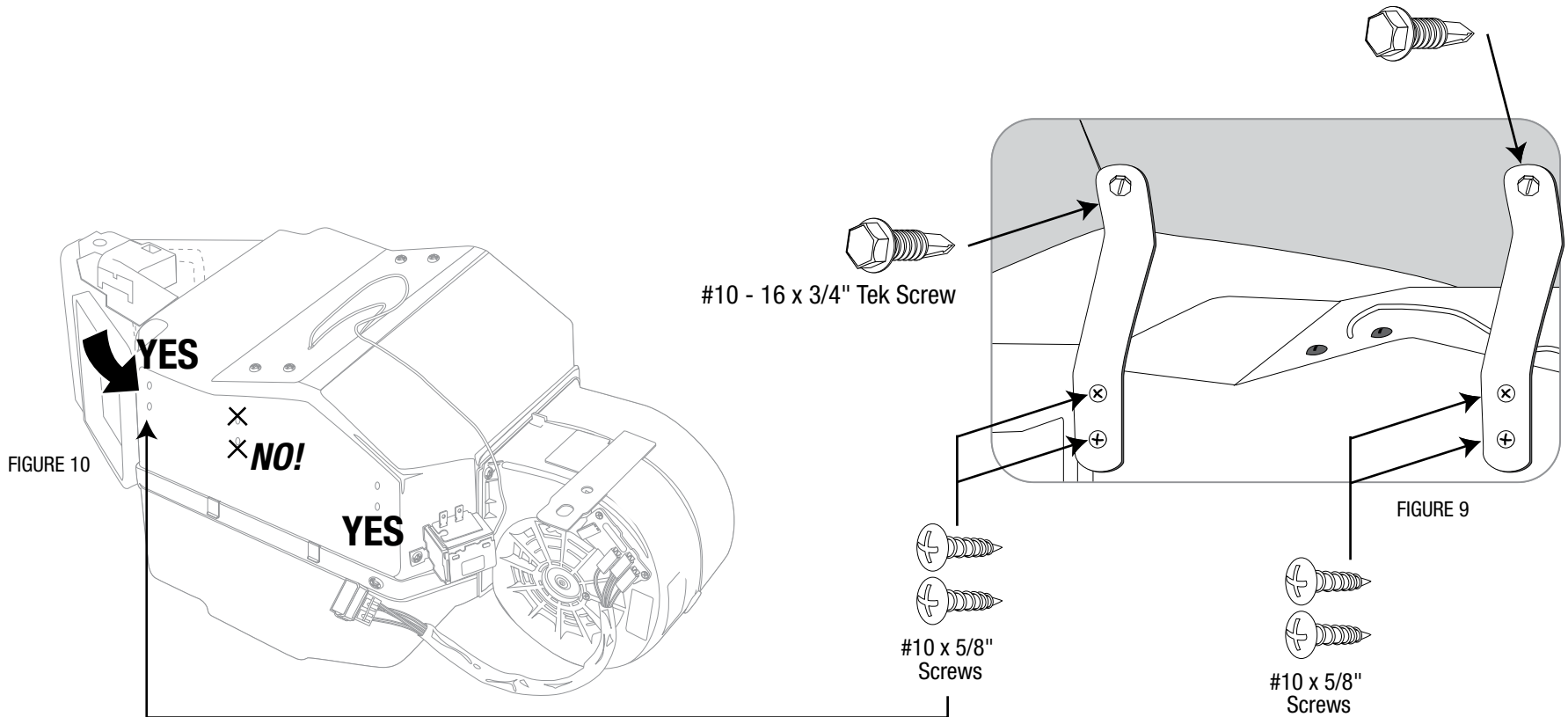

FIGURE 8

Locate in the UPPER MOUNTING BRACKETS and attach to evaporator unit using four #10 - 10 x 5/8" Phillips screws. Attach other end to the cowling with a #10 - 16 x 3/4" Tek Screws (see figure 9). **IMPORTANT NOTE: On the side of the main unit you will see several holes for mounting holes... ONLY USE THE ONES ON THE FAR LEFT AND RIGHT FOR THESE BRACKETS!** Do not tap into the other holes for any reason (see figure 10). Also, use a screwdriver and hand-power and do not over-tighten so you don't strip the holes.



Install liquid line onto the Expansion valve (TXV) as shown. Use #6 o-ring and (2) drops of mineral oil on the o-ring and tighten securely.

Install Suction Tube to the outlet on the unit as shown. Use #10 o-ring and (2) drops of mineral oil on the o-ring and tighten securely.

Locate Sensing Coil attached to Expansion valve (TXV) and utilizing Bulb Clamp, attach to the Suction Tube.

**CAUTION: THE SYSTEM WILL NOT FUNCTION PROPERLY IF THE SENSING COIL IS NOT CLAMPED IN THE CORRECT POSITION. SEE PICTURE.**

Wrap Suction Tube and Sensing Coil with the refrigerant tape provided. Be sure that all of the exposed metal is covered.

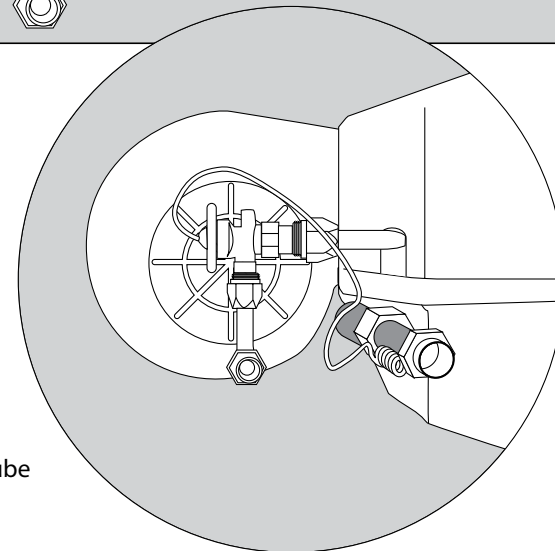
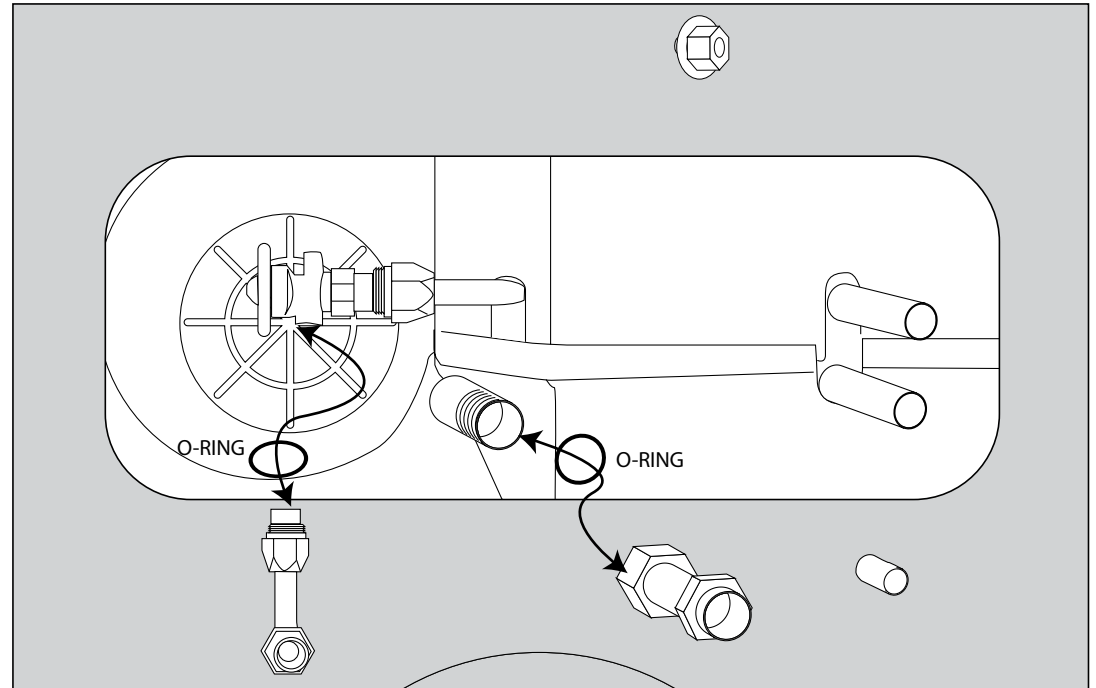

**Reminder...**  
Use two  
wrenches to  
tighten o-ring  
fittings

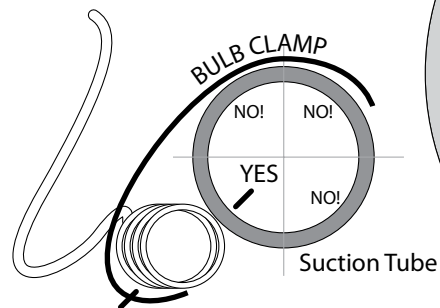
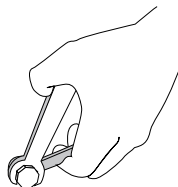

## THESE ARE THE PARTS YOU WILL FIND IN BAG KIT C

You will use all of these parts and hardware during the next series of installation steps.

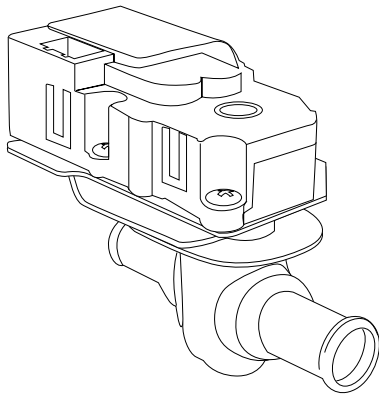

Electronic Water Control Valve  
PN#16-1081-2

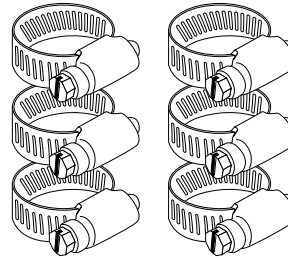

Six Worm Gear Clamps

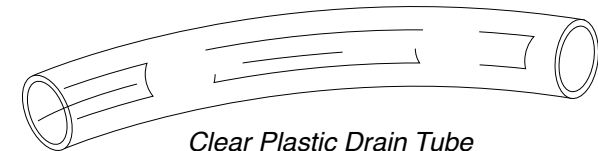

Clear Plastic Drain Tube

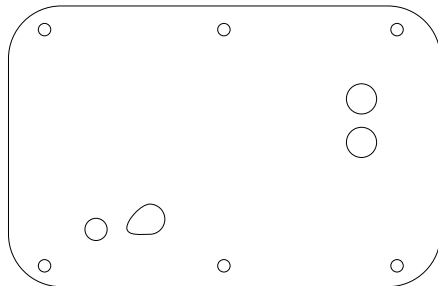

Firewall Block Off  
PN#10-1049-1

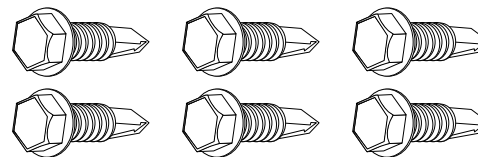

Six #10 - 16 x 3/4" Tek Screws



Refrigerant Tape

Illustrations NOT shown actual size

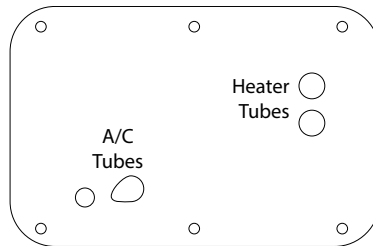

It may be necessary to manipulate the tubes slightly to get proper fitment thru the block-off plate

In **Bag Kit C** you'll find the firewall block off. Install this over the hose connections coming thru the firewall within the engine compartment. Attach with six #10 - 16 x 3/4" Tek screws. Seal around the tubes with the included refrigerant tape. This will keep unwanted moisture and debris from entering thru the firewall... so seal carefully and thoroughly.

## IMPORTANT NOTICE: PROPER INSTALLATION OF WATER VALVE!!!

**IMPORTANT NOTICE:** Classic Auto Air has done extensive testing on the correct method to install the water valve in order to get a repeatable and progressive temperature control. **The water valve MUST be installed per these instructions!... (if not, your system will not work properly... and that's an absolute fact).**

The **lower** connection on the tubes coming thru the block off assembly is going to be routed to the water outlet on the intake manifold. Attach your hose with cable clamps on both ends and route where it will not interfere with linkage or come in contact with exhaust manifolds or headers.

The **upper** port coming thru the firewall will be routed to and thru your new your electronic water valve (the water valve is marked for easy installation). First Attach a 6" piece of 5/8" dia. heater hose with the supplied worm gear clamp. Attach to the inlet side of the water valve using another supplied hose clamp. Attach a heater hose from the outlet side of the electronic water valve and route to the connection on the water pump.

Insert a 6" piece of the clear, 1/2" drain tube we included through the hole previously drilled and attach over the drain nipple. Seal around tube with refrigerant tape.

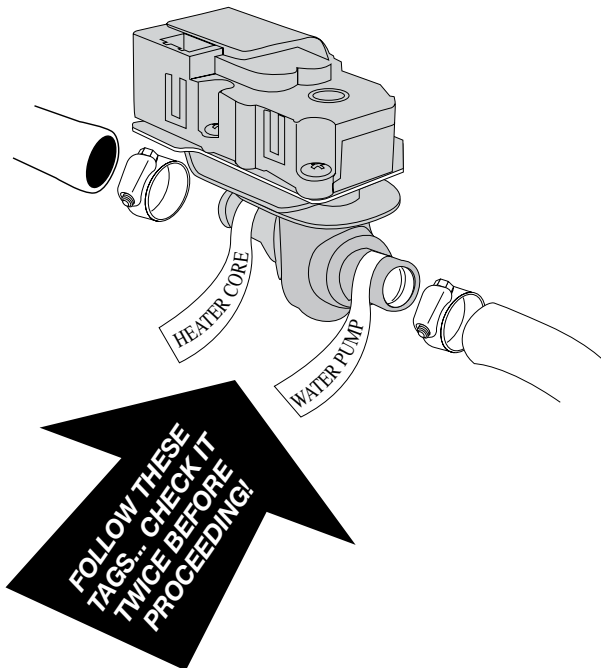

## THESE ARE THE PARTS YOU WILL FIND IN BAG KIT D

You will use all of these parts and hardware during the next series of installation steps.

The ECU will be shipped in it's own box, along with the calibration key.

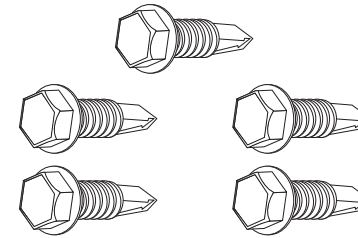
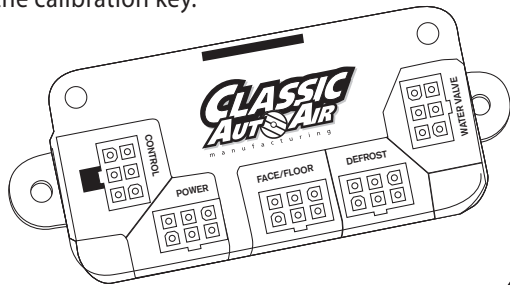

Five #10 - 16 x 3/4" Tek Screws

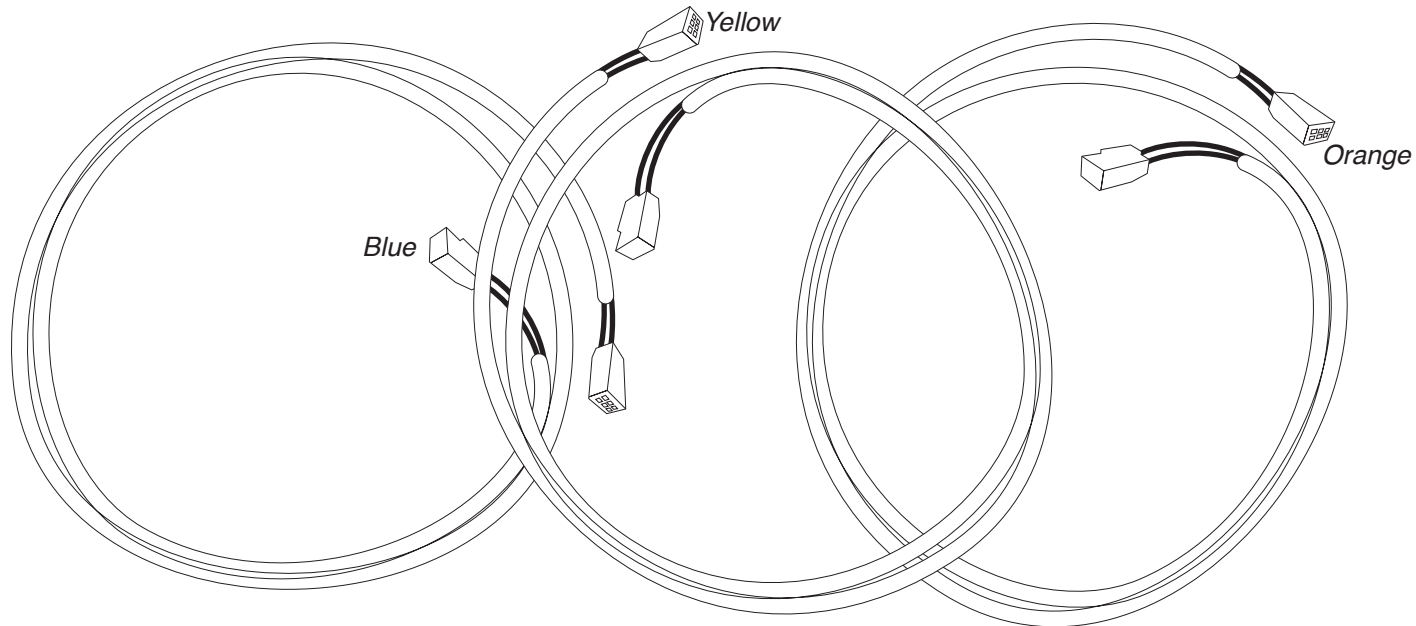

**EZ** Wire Harness System

Illustrations NOT shown actual size

We've included enough wire length to allow you to mount the ECU in a variety of places. It is very important that you mount this in a place where it will stay dry and that vibration is at a minimum. Also make sure that where ever you mount it does not interfere with any moving controls or cables. We recommend mounting it just above the right hand side of the main unit using the included tek-screws. **IMPORTANT! DON'T MOUNT THE ECU PERMANENTLY JUST YET. THAT CAN BE DONE AFTER YOU CALIBRATE THE UNIT.**

In **Bag Kit D** you will find three wiring harnesses with connections at each end. Plug the harness with YELLOW band into the YELLOW ECU port and the other end into the servo motor on the main unit (motor is marked with YELLOW INDICATOR). Repeat this process for the other two harnesses, following the color coding indicated on cables and ports. Attach cable in the engine compartment to the electronic water valve (see figure 12). Using one of the CAP PLUGS provided, slot it and install over the heater hose/cable.

**NOTE:** The GREEN harness connection will be made from the harness you previously installed, just plug the loose connection in the CONTROL port on the ECU.

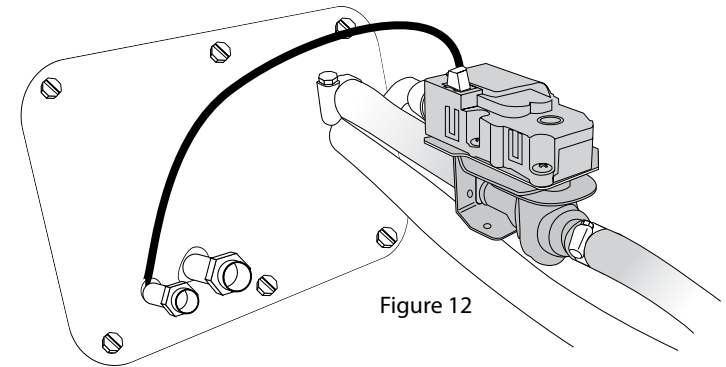
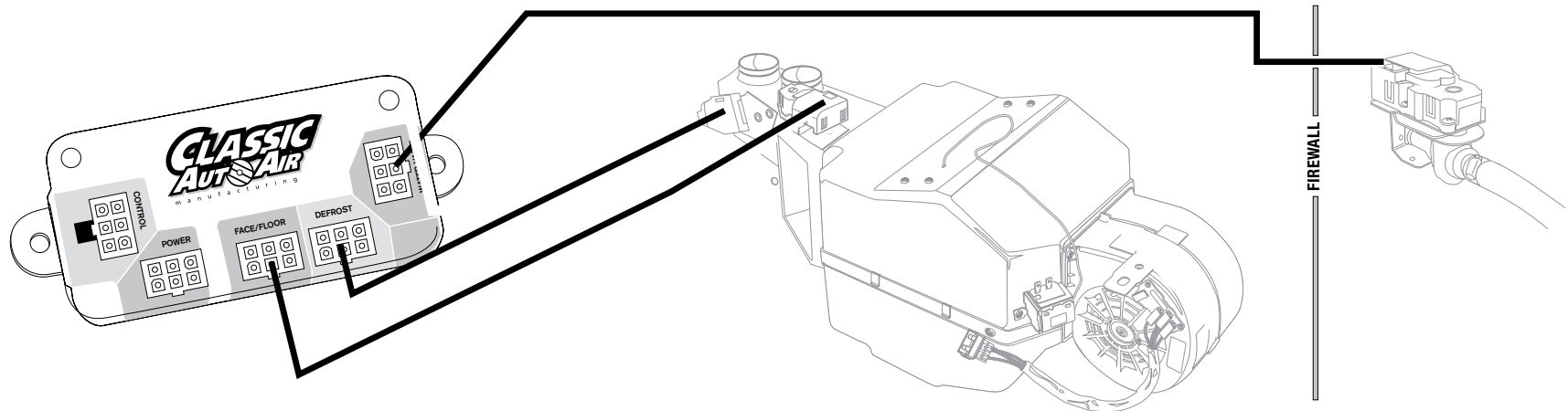

Figure 12







Temporarily reconnect the car battery at this time. You will need a full 12 volts to complete the calibration.

# WELCOME TO EZ CALIBRATION...

Follow these directions carefully and your unit will be calibrated in just a few minutes. Before we boxed and shipped your unit, we tested and calibrated it to factory specifications to make sure it is capable of operating at maximum efficiency. However, the unit must still be calibrated to your specific vehicle and controls. This is an easy process that can be done in a few steps. If for any reason your unit does not calibrate properly the first time, just turn off the unit and rerun the setup process. **NOTE: When you move a knob to a new position, do it in ONE continuous motion.**

**#1**

Plug CALIBRATION KEY into ECU

**#2**

Position your controls like this example.

**#3**

Move FAN control to medium in one motion...

LED ON 1 Second Later... LED OFF

**#4**

Move MODE control to DASH in one motion...

LED ON 1 Second Later... LED OFF

**#5**

Move TEMP control to HOT in one motion...

LED ON 1 Second Later... LED OFF

**#6**

After 1 second the LED turns back ON

You may be able to hear the internal door(s) move back and forth...

LED ON Approx. 30 Seconds Later... LED OFF

**#7**

Move the FAN knob to OFF (powers off unit)

**#8**

**REMOVE KEY AND STORE IN SAFE PLACE**

That's it. Your unit is now fully calibrated. Disconnect the battery and move on to the next phase....

# THESE ARE THE PARTS YOU WILL FIND IN BAG KITS E, F, and G

You will use all of these parts and hardware during the next series of installation steps.

## Bag E

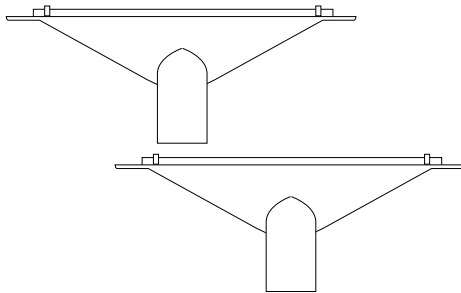

Two Defrost Diffuser  
PN#2-1054-2

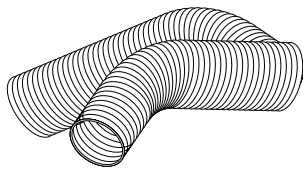

Two Duct Hoses, 2" I.D.



Four Zip-Ties

## Bag F

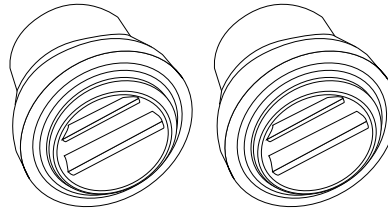

Driver & Passenger Side Louver Ball Assemblies  
PN#2-1006

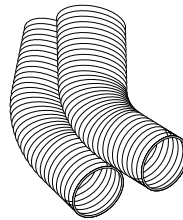

Two Duct Hoses, 2" I.D.

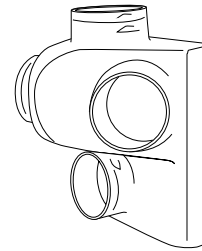

Face/Floor Assembly  
PN#2-2025-1



Four Zip-Ties

## Bag G

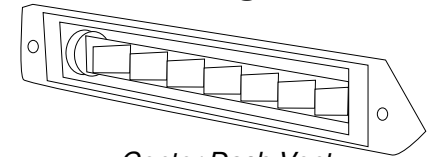

Center Dash Vent  
PN#2-1054-1

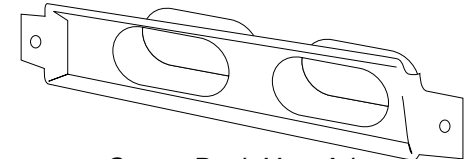

Center Dash Vent Adaptor  
PN# 2-1054-3

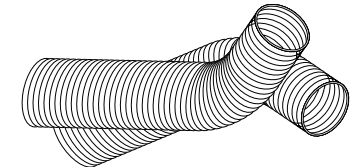

Two Duct Hoses, 2" I.D.

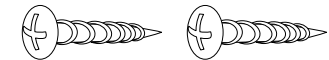

Two #6-20 x 1" Phillips Screws

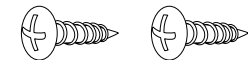

Two #10 - 10 x 5/8" Phillips Screws



Four Zip-Ties

Illustrations NOT shown actual size

**Bag Kit E. The following steps are for left and right Defrost Diffusers...**

Locate and route the duct hoses from the defrost/heat duct assembly upward toward defrost vents. Attach the flex hose to the defrost defuser using zip-ties. The other end of the duct hose is installed over the defrost/heat duct assembly outlets on main unit (see figures 13 and 14).

The face/floor assembly comes preinstalled with s-clips which allow you to install it onto the evaporator unit quickly and securely (see figure 15).

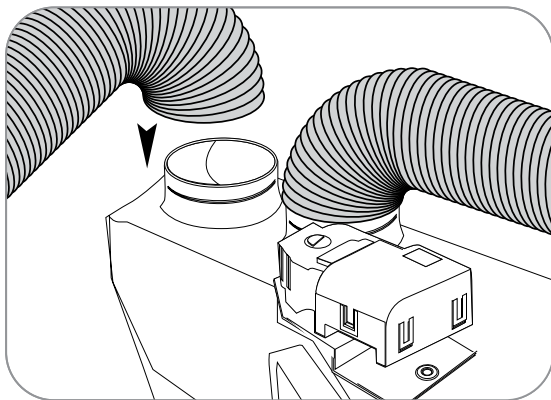
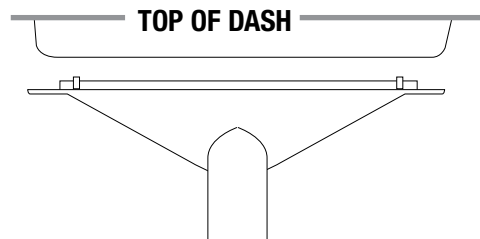

FIGURE 13



Push defrost adaptors onto lip of dash tab (below defrost vents, inside of dash), S-clips (already installed) will hold the adaptors securely

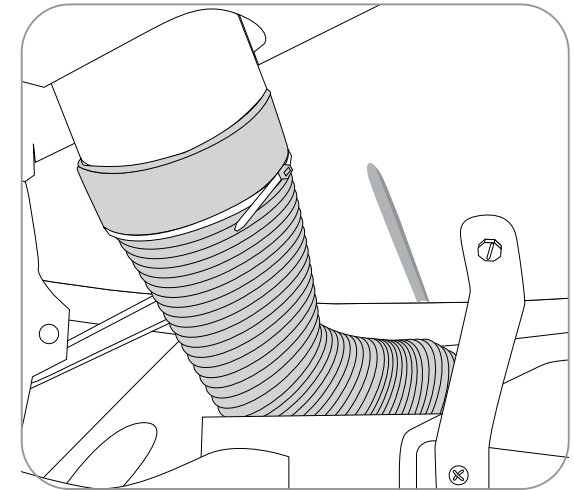

FIGURE 14

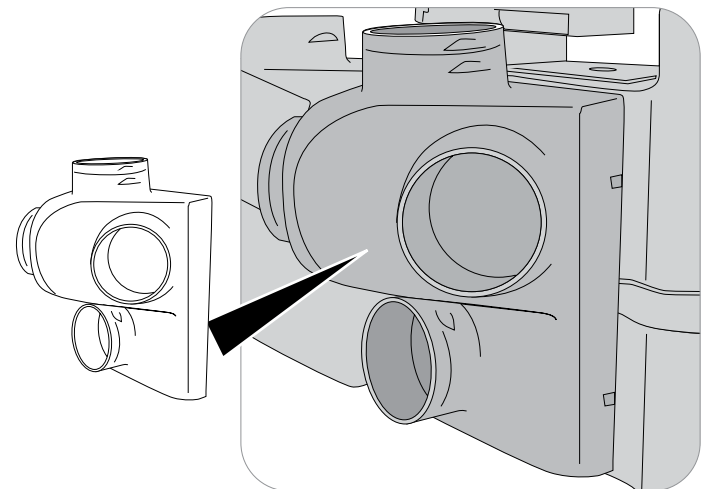

FIGURE 15

**Bag Kit F:** Carefully locate and cut a 2 ½" diameter hole on passenger panel beside the glove box opening. Attach ball louver through the hole. You'll do the same for the drivers side. Be sure to check for obstructions before drilling.

Route supplied flex hoses as shown below. Take your time and route them so they don't become kinked or torn.

During installation of the hoses be aware of the eventual movement of the wiper arm components.



The smoother the route of the flex hoses the better the airflow.

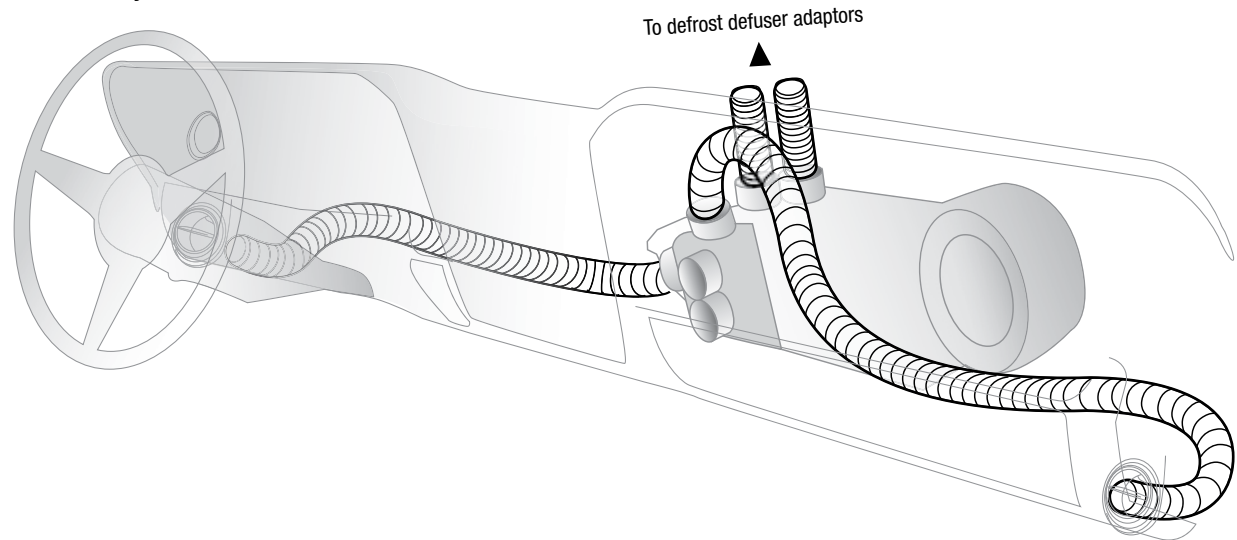

#### Passenger Side

Drill a 2.5" hole, 2" from the surrounding lip of the glovebox door seam (not glovebox opening)

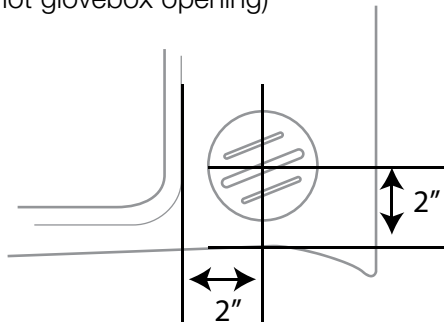

#### Drivers Side

Drill a 2.5" hole, 2" from the edge of the instrument gauges

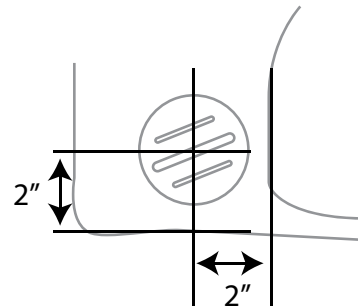

**Bag Kit G:** Installing the center louver vent requires a small amount of cutting to the dash support. If you haven't already, remove the main bezel.

Locate the center louver assembly and (2) #6 x 1" pan head philips screws.

Place louver assembly over the trim bezel and drill (2) 1/8" dia holes using the trim bezel as guide.

Attach louver assembly using (2) #6 screws.

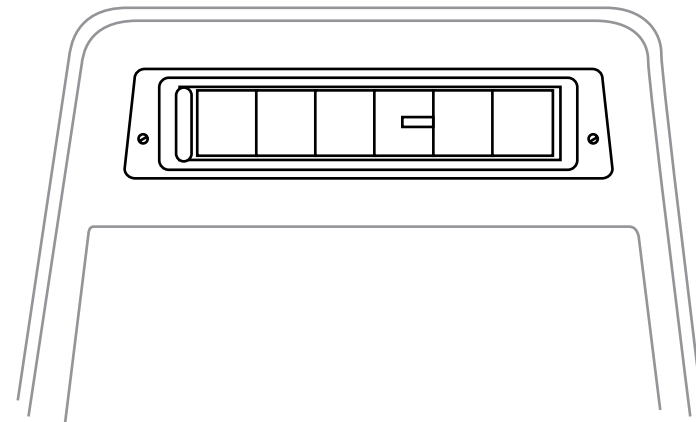
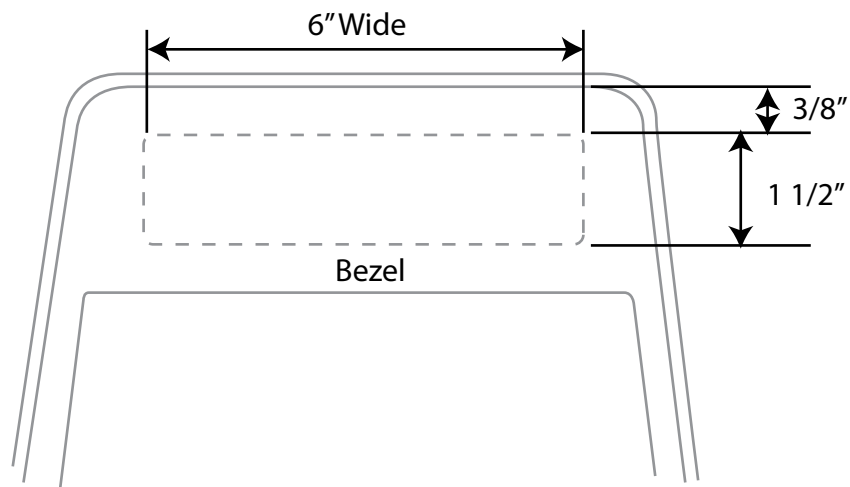
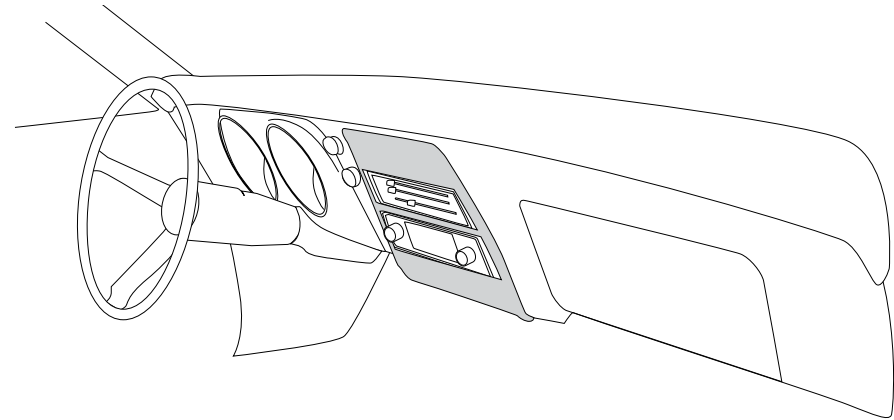

Above the control panel opening, cut out the center and down to the control opening of the block off (as shown to the right in the gray area), for the center louver assembly.

Install center hose adaptor **from behind** the opening as shown. Secure using (2) #10 x 5/8" pan head screws.

Cut (1) piece of flex hose 24" long, and one piece 19" long. Attach longest piece to the right hose adaptor using (1) #10 x 5/8" pan head screw. Other piece attaches to the left adaptor using (1) #10 x 5/8" pan head screw.

Route the hoses from the center vent to the two remaining openings on the Face/Floor assembly on the evaporator. Reinstall the bezel using the original hardware.

You can reinstall the glove box at this time, and any other interior components that we're removed.

This completes the interior portion of the **PERFECT FIT-ELITE** installation process. This is a good time to make a final check that all the controls still move freely and that nothing is loose or hanging down.

The interior of your car should look pretty much the same as before you started (or better). Plus you probably got to know the underside of your dash a lot better and might even have repaired or upgraded components that needed attention.

**Good Job... Let's move on to the major components within the engine compartment....**

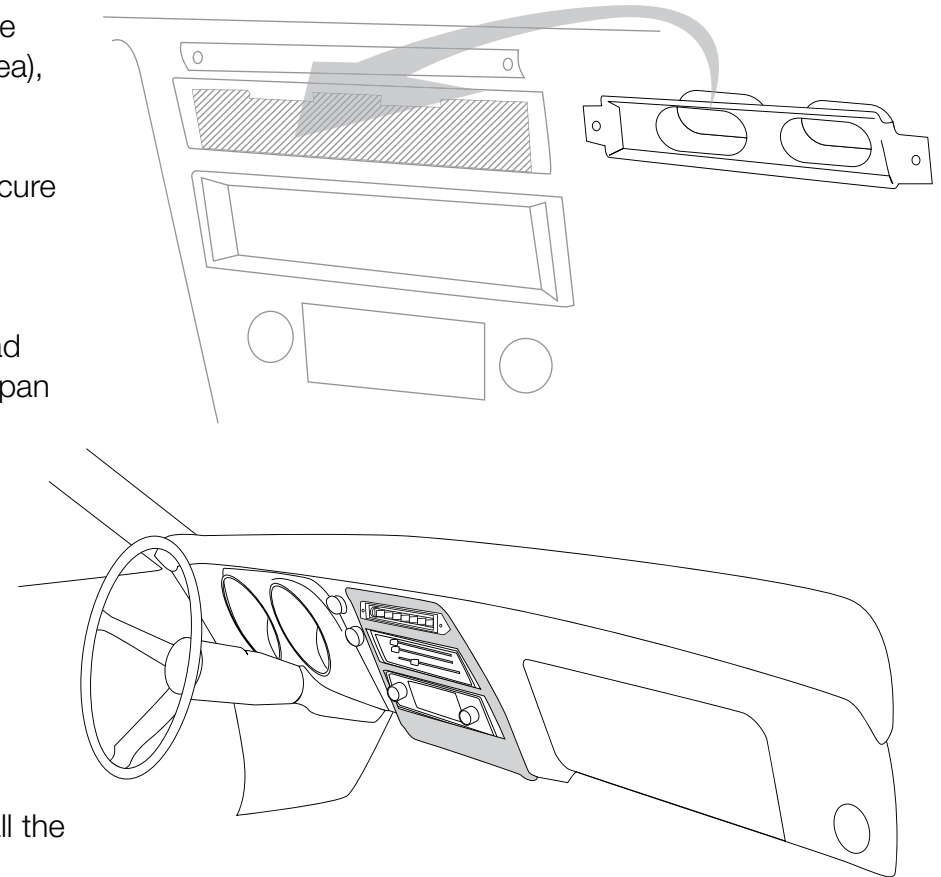

If you have any questions before you move on the final phase of this installation, call us.

**888.791.6384**

# THESE ARE THE PARTS YOU WILL NEED FOR THE ENGINE COMPARTMENT INSTALLATION

You'll find all of these parts within the main box

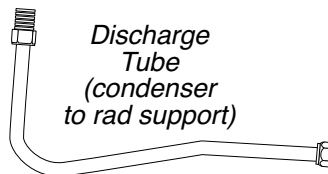
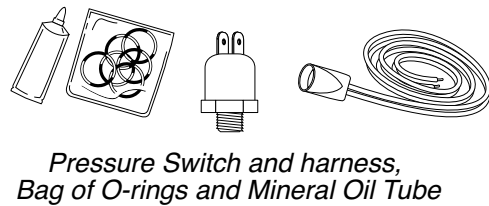
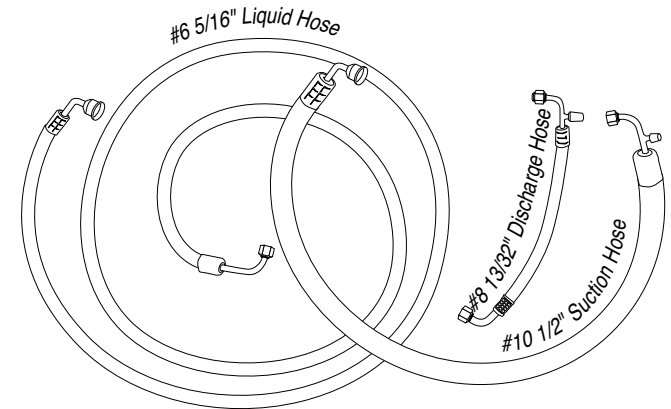
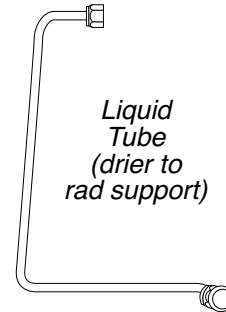
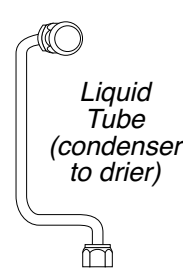
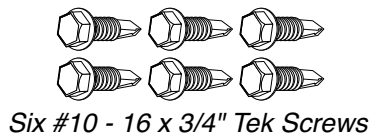
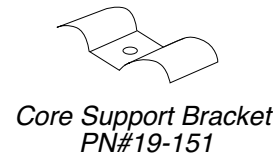
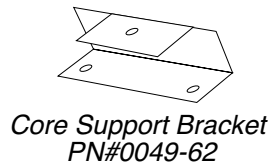
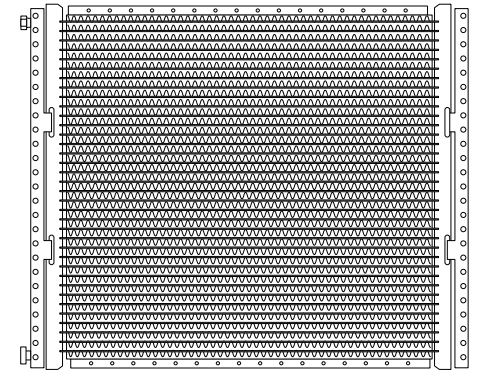
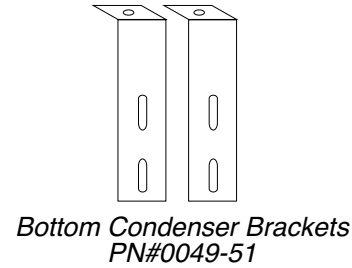
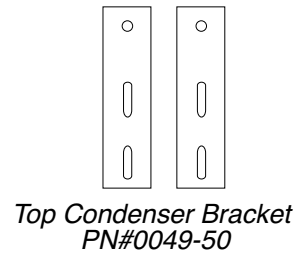
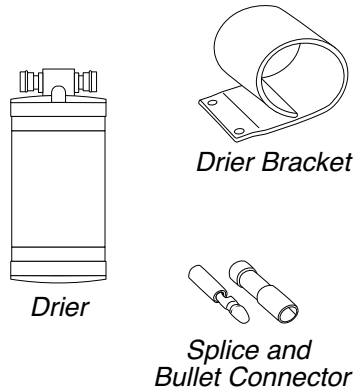

**DRIER AND CONDENSER PREPARATION.** You can perform most of the following steps on a clean flat surface like a workbench. Lay the condenser down so that both hose connections are on the left side (the larger connection will be on top). The drier is conveniently mounted on the left hand side of the condenser. First insert the drier into the drier mounting bracket (it's basically a sleeve for the drier). Attach the drier liquid tube to the drier and also to the connection on the condenser (tighten connections at either end using supplied o-rings on both ends and a few drops of mineral oil to each o-ring). With these two components combined it will be easy to find the correct place to attach the drier bracket to the condenser with the included #10-20 x 1/4" screws (attach drier and bracket from the front of the condenser).

**PRESSURE SWITCH:** Screw the high-pressure switch into the port on the top of the drier. Go ahead and plug the pressure switch harness into the switch at this time (black electrical boot with two long white wires).

**BRACKETS:** Install the upper condenser bracket using four #10 - 20 x 1/4" screws in the top two holes on each side. Next, attach the lower brackets using the bottom two holes, with the same size screws. These brackets have a bend that will face away from you.



**Reminder...**  
Use two  
wrenches to  
tighten o-ring  
fittings

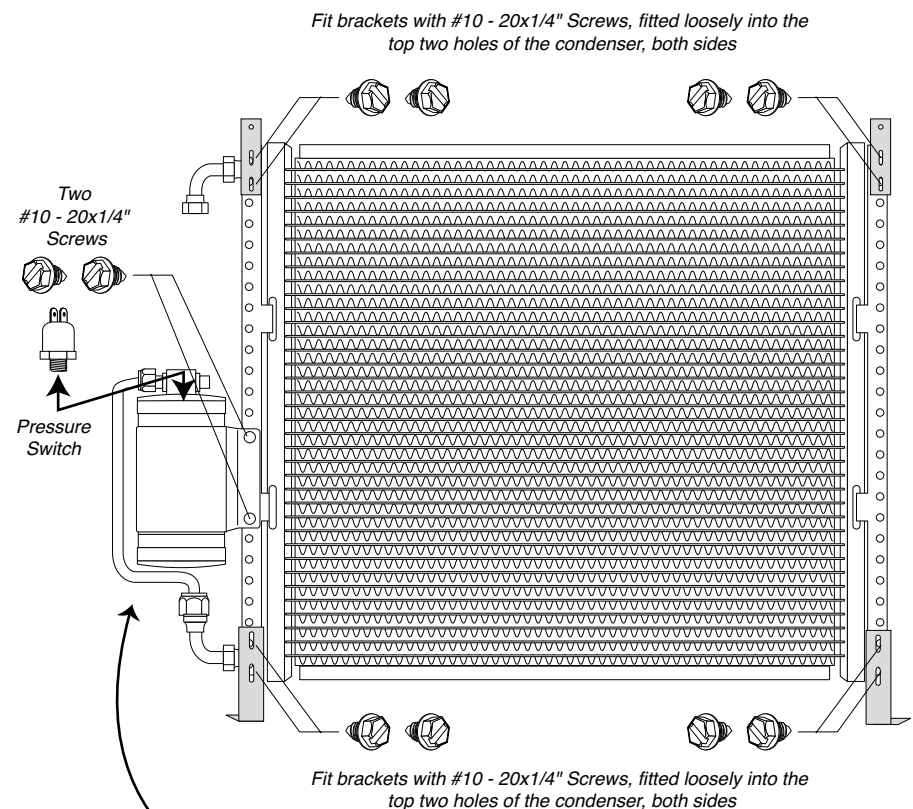
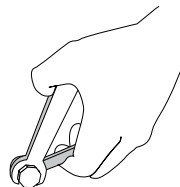

You can easily find the correct position for mounting the drier to the condenser by using the drier liquid tube as a gauge.

Remove the hood latch assembly. Retain original hardware. Slide condenser assembly down in front of the radiator.

Locate condenser in the center of the radiator. Attach top condenser brackets to the bulkhead using (2) #10 Tek screws.

Located behind the air damn and at the lower radiator bulkhead, attach the lower condenser brackets using (2) # 10 Tek screws.

Reinstall hood latch assembly using original hardware.

Locate the Liquid tube, Discharge tube, (1) #6 o-ring, and (1) #8 o-ring. Attach Liquid tube to the drier using the #6 o-ring and a few drops of mineral oil. Attach Discharge tube to the condenser using #8 o-ring and a few drops of mineral oil.

Locate the tube support bracket, the tube clamp, and (2) #10 x  $\frac{3}{4}$ " tek screws, and (1) #10 x  $\frac{1}{2}$ " hex head screw.

Attach the support bracket to the radiator bulkhead using (2) #10 x  $\frac{3}{4}$ " tek screws.

Attach liquid and discharge tubes using the tube clamp, using (1) #10 x  $\frac{1}{2}$ " screw.

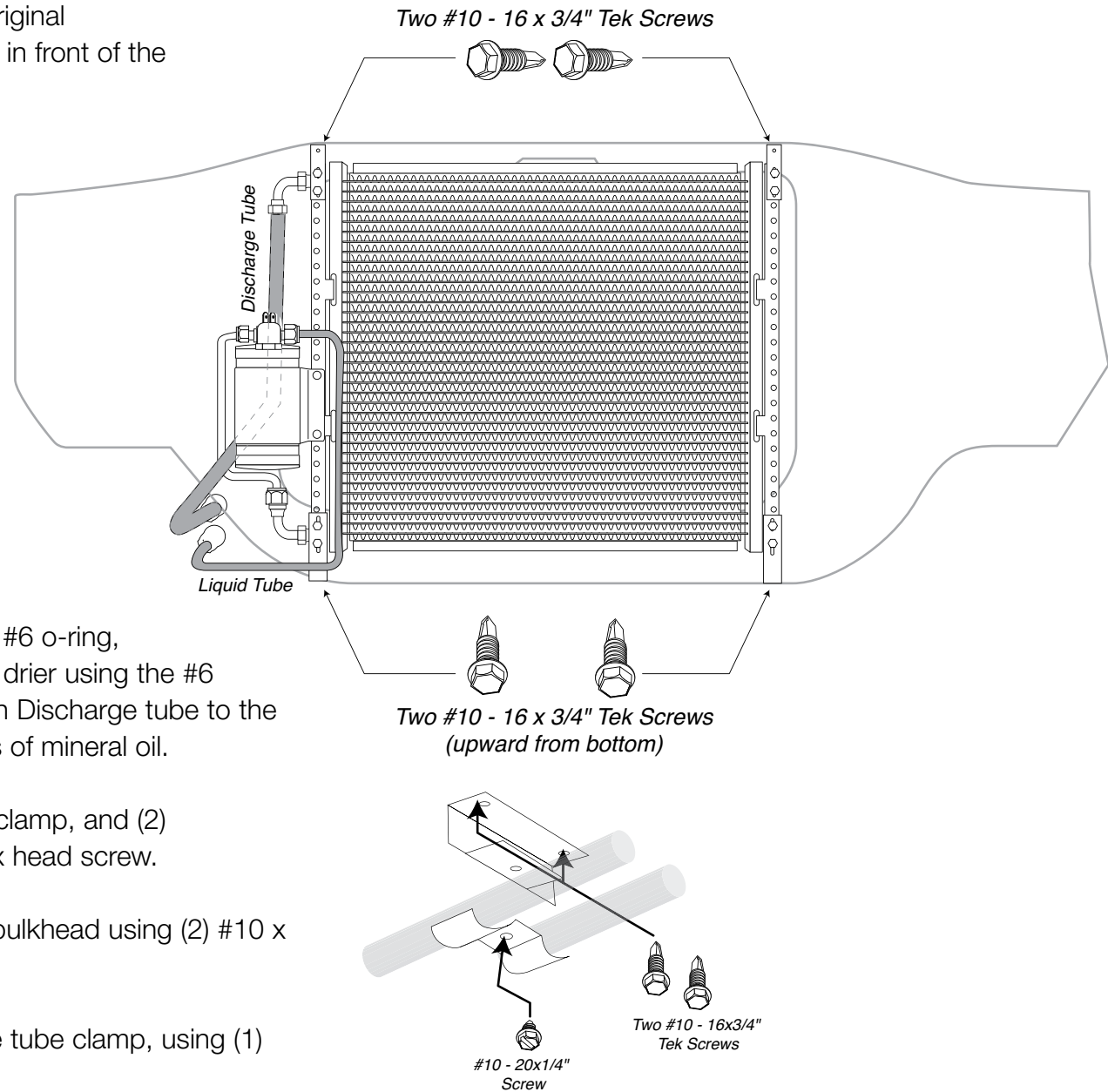

**Time to install the compressor kit.** Included in your box is a premium compressor kit with all the parts you'll need to install the compressor. This kit includes instructions specifically written for your engine. Once you've installed the complete compressor kit, continue on to connecting the hoses.

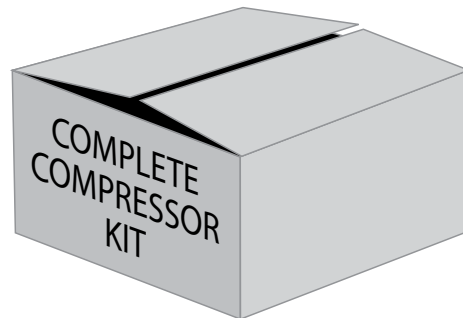

### CONNECTING THE HOSES:

- 1) Attach the #8 Discharge Hose (13/32") from the connection under the core support and route to the compressor. Tighten fittings using o-rings and mineral oil provided.
- 2) Attach the #6 liquid hose (5/16") from the connection under the core support connection at the firewall on the evaporator unit (see figure 41). Tighten fittings using o-rings and mineral oil supplied in kit.
- 3) Attach the #10 suction hose (1/2") to the compressor and route as mentioned above. Tighten fittings using o-rings and mineral oil supplied in the kit.

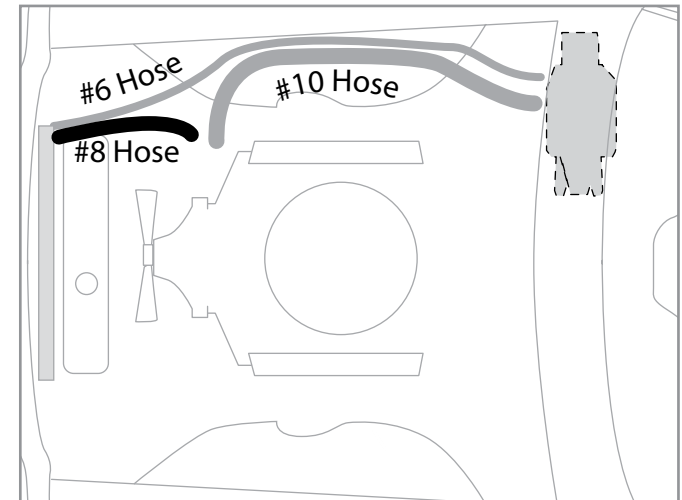

Passenger Side Compressor

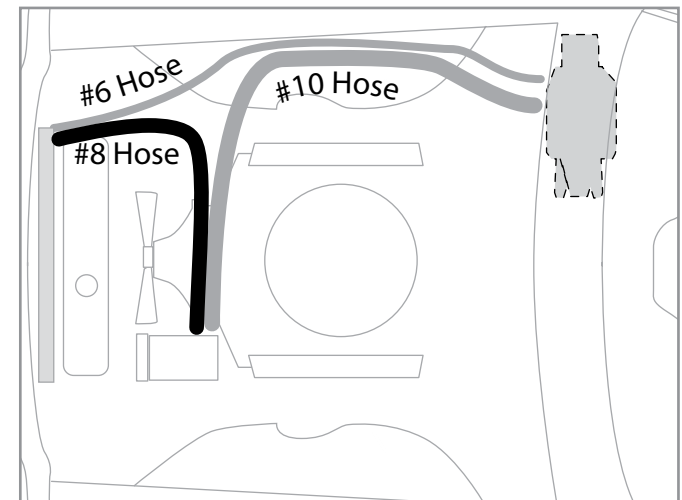

Drivers Side Compressor



Connect the pressure switch by first connecting one wire to the connection on the compressor, and the other wire will be routed along with the liquid hose and connected to the blue lead you put thru the firewall during the interior installation (for attachment route. We've included a bullet and slice connector to make these connections, use a crimp tool to secure these properly.

**FINAL STEPS:** Take a look around at your installation and check all fittings and bolts for tightness, check the heater hose clamps for tightness, and make sure nothing is routed in a way to obstruct any moving parts. **You can refill the radiator and reconnect the battery at this time.**

---

**WAY TO GO! You've just completed the installation of your new A/C system.  
The very final step is to fully charge and test your new system.**

**On the next page you'll find specifications for proper final preparation  
for your A/C technician.**

## New A/C System Preparation... A MUST READ!

Please read thru these procedures before completing this new A/C system charging operation.

**A licensed A/C technician should be utilized for these procedures to insure that your new system will perform at it's peak, and that your compressor will not be damaged.**

- 1) Your radiator/cooling system is an integral part of your new system. Please insure that you have a 50/50 mix of distilled water and antifreeze. The heater coil **MUST** be purged (cycle heater control valve) to make sure no water, without antifreeze, is in the heater coil before you charge the A/C system.
- 2) Evacuate the system for 45 minutes (minimum).
- 3) **Your new compressor MUST be hand-turned 15-20 revolutions before and after charging with liquid. Failure to do this may cause the reed valves to become damaged** (this damage is NOT covered by your warranty).
- 4) Your new system requires 134a refrigerant. It will require 1.5 lbs (or 24 oz).
- 5) Your new compressor comes charged with oil - NO additional oil is needed.
- 6) Insure that the new belt is tight.
- 7) DO NOT CHARGE SYSTEM WITH LIQUID WHILE THE ENGINE IS RUNNING!

RECOMMENDED TEST CONDITIONS: (After system has been fully charged and tested for basic operation)

- Determine the temperature outside of the car
- Connect gauges or service equipment to high/low charging ports
- Place blower fan switch on medium
- Close all doors and windows on vehicle
- Place shop fan directly in front of condenser
- Run engine idle up to approx. 1500 rpm

ACCEPTABLE OPERATING PRESSURE RANGES:

1. HIGH-SIDE PRESSURES (150-250 PSI)
2. LOW-SIDE PRESSURES (15-25 PSI in a steady state)

Readings above are based on an ambient temperature of 90° with an adequate airflow on condenser

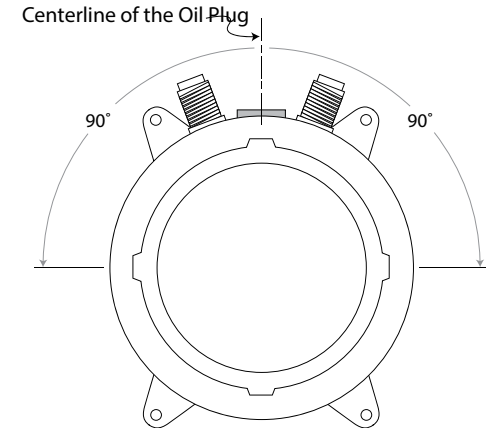

**CAUTION!** When mounting your compressor and/or adjusting the belt, use caution not to tilt the compressor up to or more than 90° off the centerline of the oil fill plug. This can cause compressor failure.

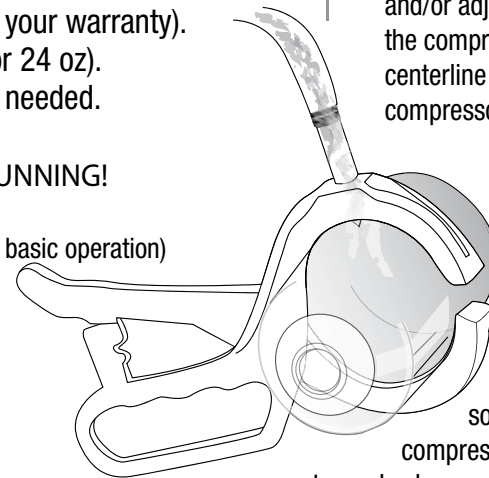

**Do NOT tilt, shake or turn refrigerant can upside-down OR use a charging station to install refrigerant while the engine is running.** Doing

so will direct liquid refrigerant into the compressor piston chamber, causing damage to reed valves and/or pistons and/or other components, as well as potentially seizing the compressor. Allow a minimum of 30 minutes for liquid to "boil off." You must hand turn the compressor hub (not the pulley) a minimum of 15 complete revolutions prior to starting the engine with the clutch engaged.

## TROUBLESHOOTING GUIDE

### TEST CONDITIONS USED TO DETERMINE SYSTEM OPERATION

(THESE TEST CONDITIONS WILL SIMULATE THE AFFECT OF DRIVING THE VEHICLE AND GIVE THE TECHNICIAN THE THREE CRITICAL READINGS THAT THEY WILL NEED TO DIAGNOSE ANY POTENTIAL PROBLEMS).

- B. CONNECT GAUGES OR SERVICE EQUIPMENT TO HIGH/LOW CHARGING PORTS.
- C. PLACE BLOWER FAN SWITCH ON MEDIUM.
- D. CLOSE ALL DOORS AND WINDOWS ON VEHICLE.
- E. PLACE SHOP FAN IN FRONT OF CONDENSER.
- F. RUN ENGINE IDLE UP TO 1500 RPM.

### ACCEPTABLE OPERATING PRESSURE RANGES (R134A TYPE)

- 1. HIGH-SIDE PRESSURES ( 160-250 PSI ) *\*Note- general rule of thumb is two times the ambient (daytime) temperature, plus 15-20%.*
- 2. LOW-SIDE PRESSURES ( 06-22 PSI in a steady state).

**CHARGE AS FOLLOWS: R134A = 24 OZ.**

**NO ADDITIONAL OIL IS NECESSARY IN OUR NEW COMPRESSORS.**

### TYPICAL PROBLEMS ENCOUNTERED IN CHARGING SYSTEMS

**NOISY COMPRESSOR.** A noisy compressor is generally caused by charging a compressor with liquid or overcharging

- A. If the system is overcharged both gauges will read abnormally high readings. This is causing a feedback pressure on the compressor causing it to rattle or shake from the increased cylinder head pressures. System must be evacuated and re-charged to exact weight specifications.
- B. **Heater control valve installation** - Installing the heater control valve in the incorrect hose. Usually when this occurs the system will cool at idle then start to warm up when raising the RPM's of the motor. **THE HEATER CONTROL IS A DIRECTIONAL VALVE; MAKE SURE THE WATER FLOW IS WITH THE DIRECTION OF THE ARROW.** As the engine heats up that water transfers the heat to the coil, thus overpowering the a/c coil. A leaking or faulty valve will

have a more pronounced affect on the unit's cooling ability. Installing the valve improperly (such as having the flow reversed) will also allow water to flow through, thus inhibiting cooling. Check for heat transfer by disconnecting hoses from the system completely. By running down the road with the hoses looped backed through the motor, you eliminate the possibility of heat transfer to the unit.

- C. **Evaporator freezing** - Freezing can occur both externally and internally on an evaporator core. External freeze up occurs when the coil cannot effectively displace the condensation on the outside fins and the water forms ice (the evaporator core resembles a block of solid ice), it restricts the flow of air that can pass through it, which gives the illusion of the air not functioning. The common cause of external freezing is the setting of the thermostat and the presence of high humidity in the passenger compartment. All door and window seals should be checked in the event of constant freeze-up. A thermostat is provided with all units to control the cycling of the compressor.
- D. **Internal freeze up** occurs when there is too much moisture inside the system. The symptoms of internal freeze up often surface after extended highway driving. The volume of air stays constant, but the temperature of the air gradually rises. When this freezing occurs the low side pressure will drop, eventually going into a vacuum. At this point, the system should be checked by a professional who will evacuate the system and the drier will have to be changed.
- E. **Inadequate airflow to condenser** - The condenser works best in front of the radiator with a large supply of fresh air. Abnormally high pressures will result from improper airflow. Check the airflow requirements by placing a large capacity fan in front of the condenser and running cool water over the surface. If the pressures drop significantly, this will indicate the need for better airflow.
- F. **Incorrect or inadequate condenser capacity** - Incorrect condenser capacity will cause abnormally high head pressures. A quick test that can be performed is to run cool water over the condenser while the system is operating, if the pressures decrease significantly, it is likely a airflow or capacity problem.
- G. **Expansion valve failure** - An expansion valve failure is generally caused by dirt or debris entering the system during assembly. If an expansion valve fails it will be indicated by abnormal gauge readings. A valve that is blocked will be indicated by high side that is unusually high, while the low side will be unusually low or may even go into a vacuum. A valve that is stuck open will be indicated by both the high and low pressures rising to unusually high readings, seeming to move toward equal readings on the gauges.
- H. **Restrictions in system** - A restriction in the cooling system will cause abnormal readings on the gauges. A high-side restriction ( between the compressor and the drier inlet ) will be indicated by the discharge gauges reading excessively high. These simple tests can be performed by a local shop and can help determine the extent of the systems problem.

## Trouble Shooting Your Classic Auto Air A/C System

**PROBLEM: system is not cooling properly**  
**ISSUE: cold at idle, warmer when raising engine RPM's**

### Make sure the Water Valve is positioned correctly

The water valve is a directional valve and should be installed with the arrow pointing towards the water pump, it should be connected to the heater hose that runs from the heater core to the water pump. If the water valve is connected to the incorrect hose it allows water to circulate through the system via the heater core over powering the cooling effect of the A/C coil, (normally the air conditioning is functioning properly).

**Step 1:** Check placement of the water valve, correct if needed. (In some cases changing the location of the water valve may not fix the above problem.) Continue to next step.

**Step 2** If changing the location of the water valve does not rectify the issue, then possibly the water valve is permanently damaged and may need to be replaced. To check the integrity of the water valve completely remove the water hoses for the heater core and "loop" together. (This will remove the heater system completely from the possibilities) If the system now cools, replace the water valve

### **Verify Adequate Air Flow to Condenser**

For an air conditioning system to function properly there has to be adequate airflow across the condenser. The function of the condenser is to dissipate heat, without proper airflow your system will not cool correctly in the cabin of your vehicle.

**Step 1:** connect gauges to a/c hoses. The pressures should be: with the ambient temp is 90, low side pressures should be between 8-25 psi, high side pressures should be between 160-260psi

**Step 2:** IF the low side pressures are normal and the high side pressures are high then there might be an airflow issue, continue to next step.

### **To test air flow to Condenser do the following three tests:**

1. Place a piece of paper on the condenser with the car in idle and see if paper is held in place.
2. With car in idle, attach gages, and place a large capacity fan in front of the condenser. What happens to the pressures?
3. With car still in idle and gages attached, pour water down the front of the condenser. What happens to the pressures?

If the paper is held in place you are at least getting some air flow. If the high side decreases during test 2 & 3 then your condenser is not getting enough air which is causing your system to not cool properly. To correct this issue you will need a more powerful mechanical fan.

### **Step 3: Confirm correct Refrigerant charge in System**

All of our systems should be charged with 24oz or 1.8lbs of R134 Refrigerant only. If overcharged you will need to evacuate the system and recharge with the correct amount.\*

### **What measurements mean:**

Low Temp and High Pressure seem to be equal...

You have a malfunctioning expansion valve that is stuck open.

High Side is extremely high and Low Side is extremely low (possibly into vacuum)...

There is a blockage in the system. Remove hoses and blow compressed air through in both directions. If pressures don't change its possible that your expansion valve is stuck closed and would have to be replaced.

### **\*Compressor Concerns:**

This is often misdiagnosed as a problem for the system not cooling properly. If you have a noisy compressor it is due to improper charging of refrigerant. An overcharged (more than 24oz or 1.8lbs R134) compressor can cause rattling. If charged with pure liquid there is a high probability you have bent reed valves that are causing tapping sound.