

# ***Installation Manual***

---

## ***1967-72 Chevrolet Pickup*** *Factory Air*

DOCUMENT #1-2033FA BENCH CALIBRATION INSTRUCTIONS

©2018 Classic Auto Air / 12.18





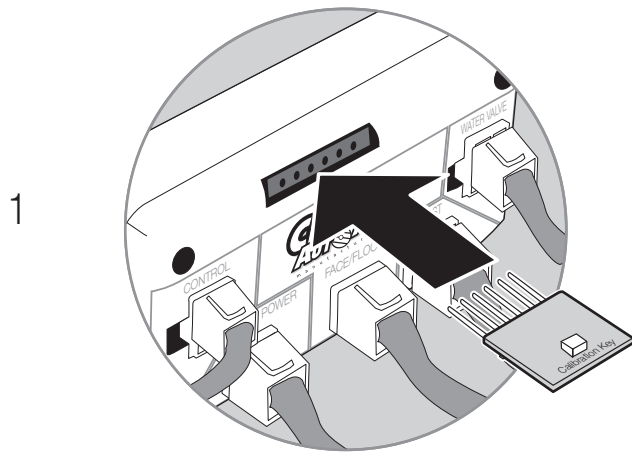

Insert Calibration Key as shown (LED up) into 6-pin connection in ECU

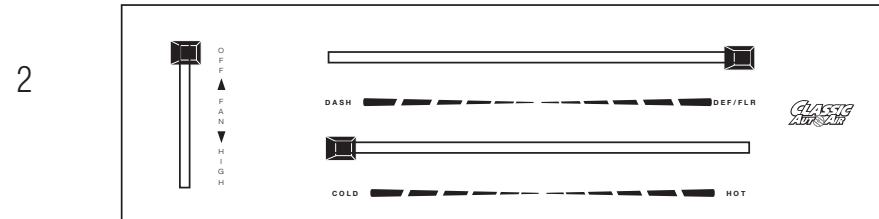

Start by positioning the control knobs as shown:  
 Fan: Off  
 Mode: Def/Flr  
 Temp: Cold

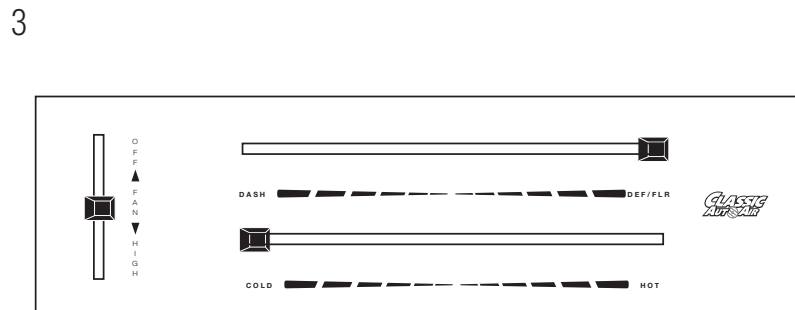

Move Fan Knob to Center..

YOU WILL SEE...

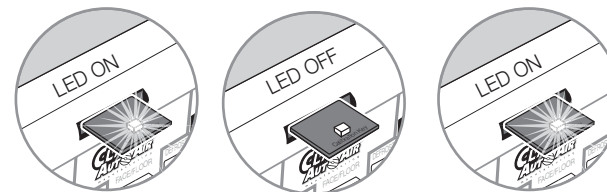

4

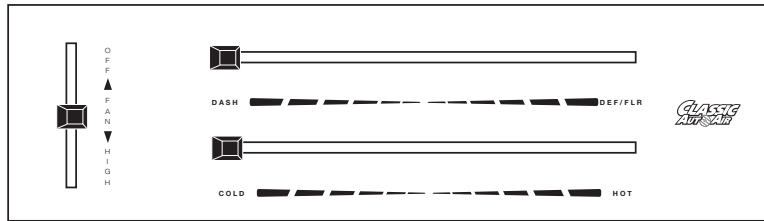

Move MODE knob to DASH  
in one motion

AFTER YOU MOVE THE KNOB YOU WILL SEE...

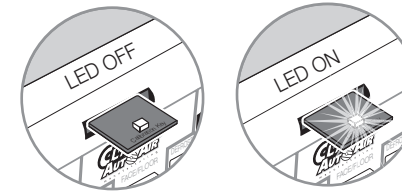

5

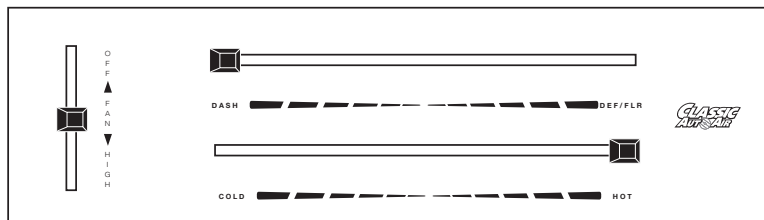

Move TEMP knob to HOT  
in one motion

AFTER YOU MOVE THE KNOB YOU WILL SEE...

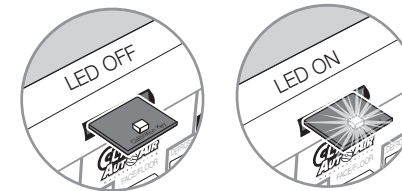

You will be able to hear the internal door(s) move back and forth and feel air coming out of the outlets

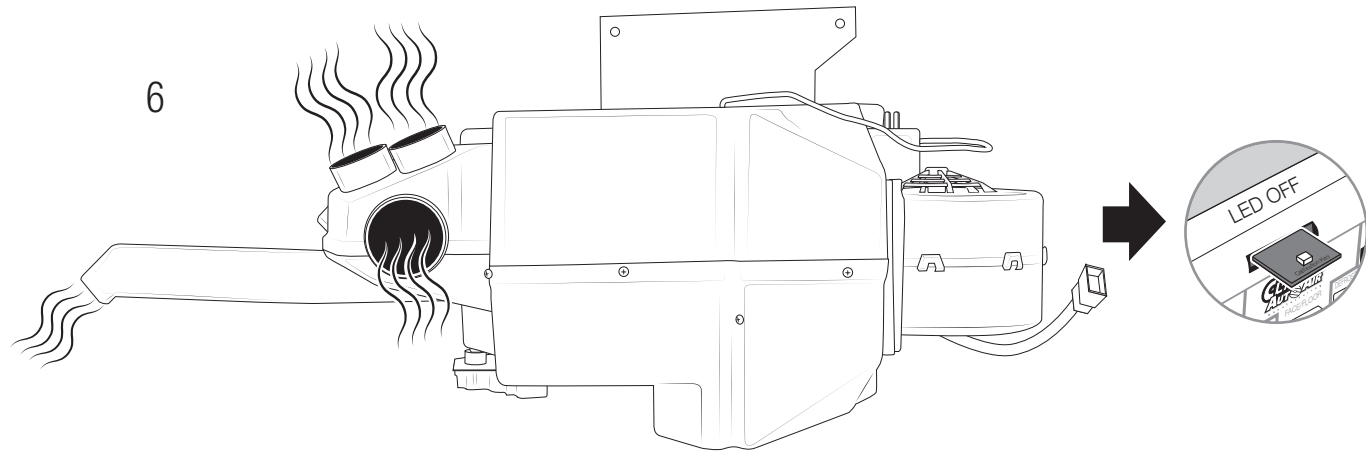

7

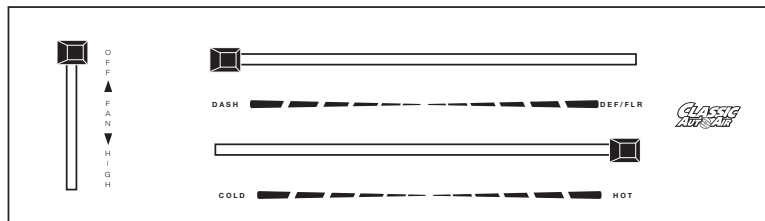

Move FAN knob to OFF

8

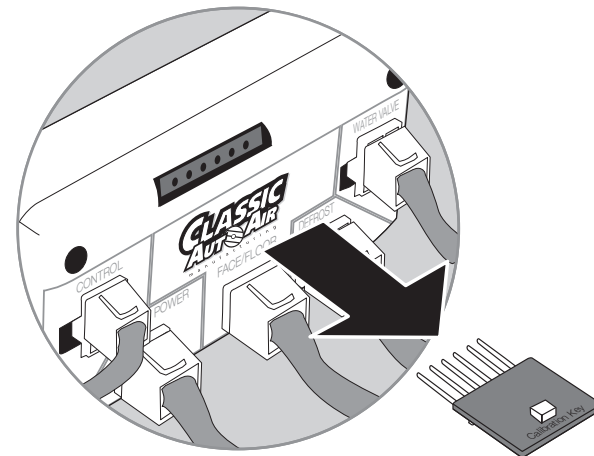

**REMOVE CALIBRATION KEY FROM ECU AND STORE IN A SAFE PLACE**

