

Installation Manual

1970-1972 Chevelle/Malibu

DOCUMENT #1-2050 BENCH CALIBRATION INSTRUCTIONS

©2018 Classic Auto Air / 12.18



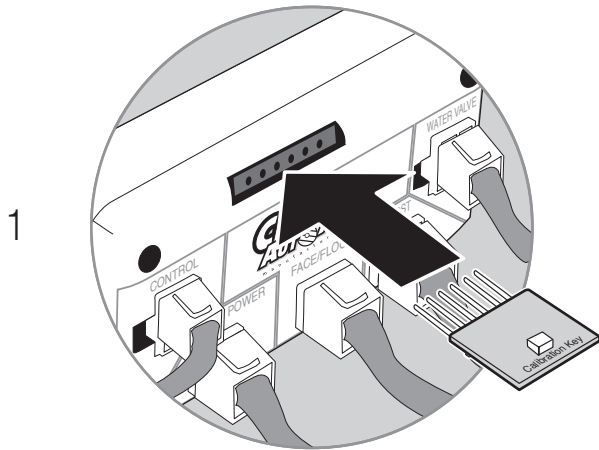

Insert Calibration Key as shown (LED up) into 6-pin connection in ECU

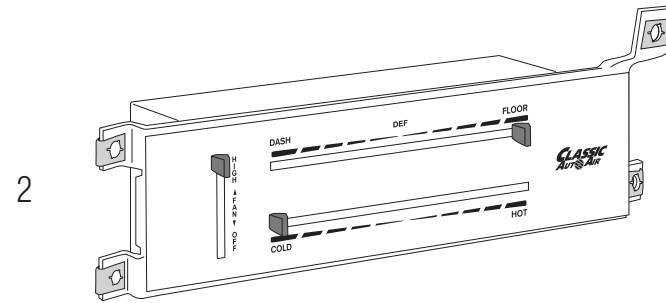

Start by positioning the Control knobs as shown:
Fan: Off
Mode: Floor
Temp: Cold

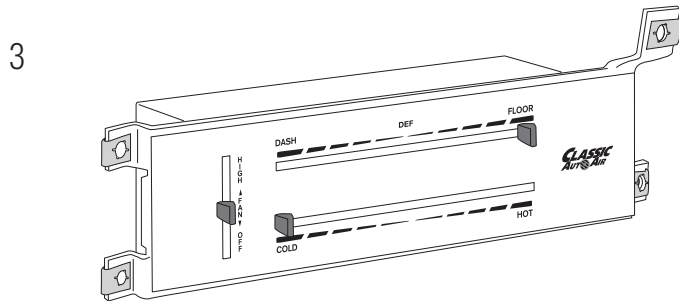

Move Fan Knob to Center...

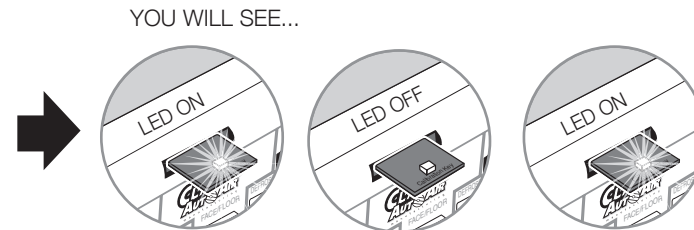

4

Move MODE knob to DASH
in one motion

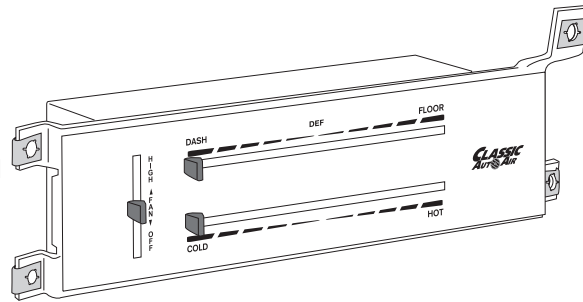

AFTER YOU MOVE THE KNOB YOU WILL SEE...

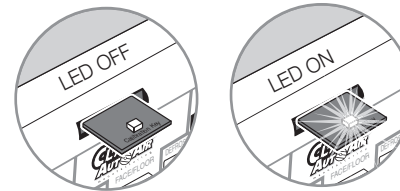

5

Move TEMP knob to HOT
in one motion

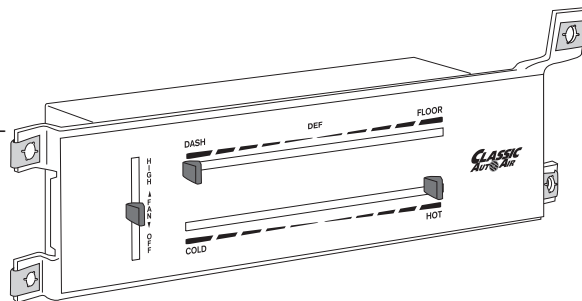

AFTER YOU MOVE THE KNOB YOU WILL SEE...

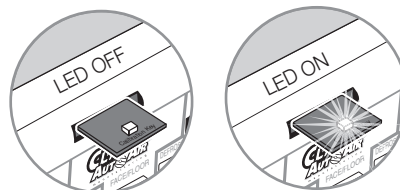

6

You will be able to hear the internal door(s) move back and forth and feel air coming out of the outlets

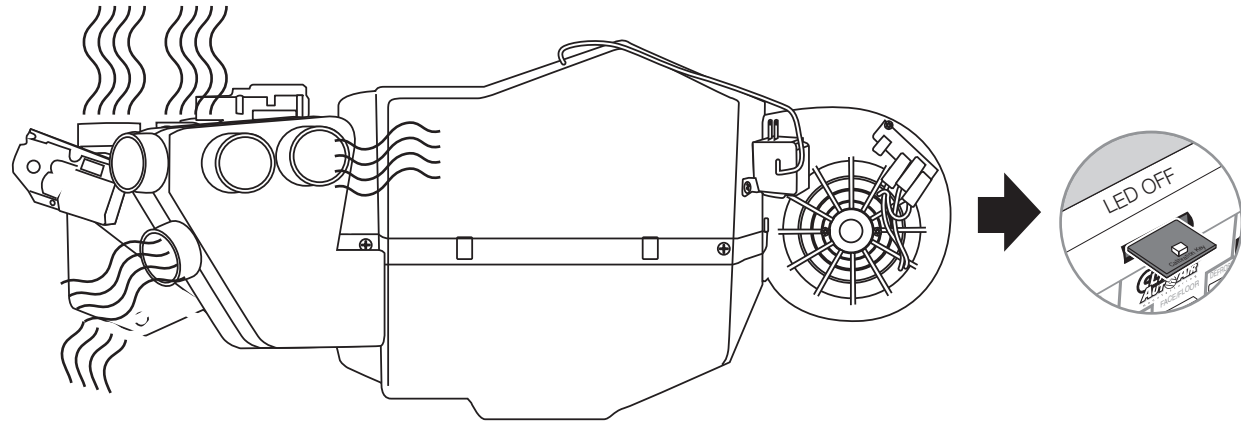

7

Move FAN knob to OFF

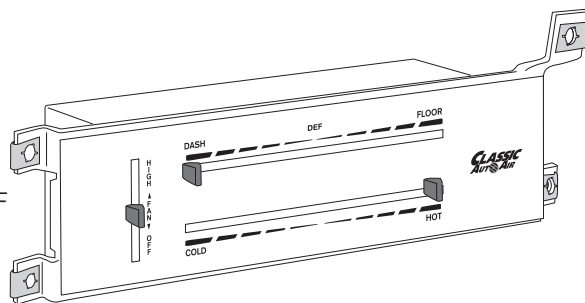

8

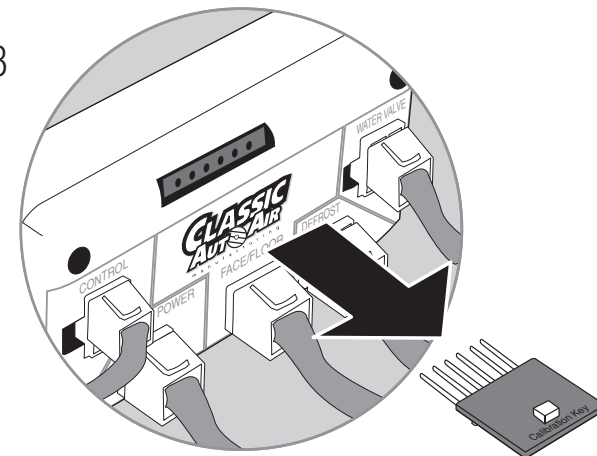

REMOVE CALIBRATION KEY FROM ECU AND STORE IN A SAFE PLACE

