

Installation Manual

1969 Camaro

DOCUMENT #1-2056 BENCH CALIBRATION INSTRUCTIONS

©2018 ClassicAutoAir / 12.18



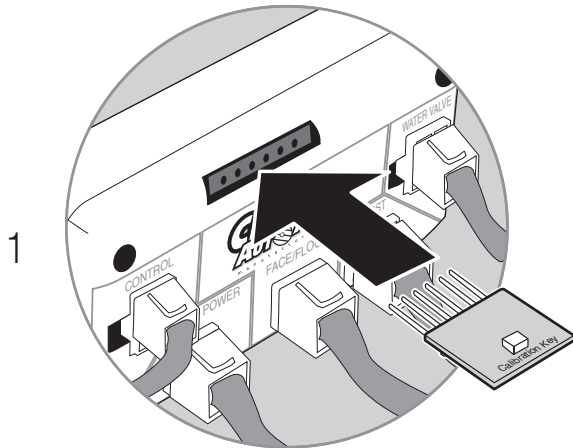

Insert Calibration Key as shown (LED up) into 6-pin connection in ECU

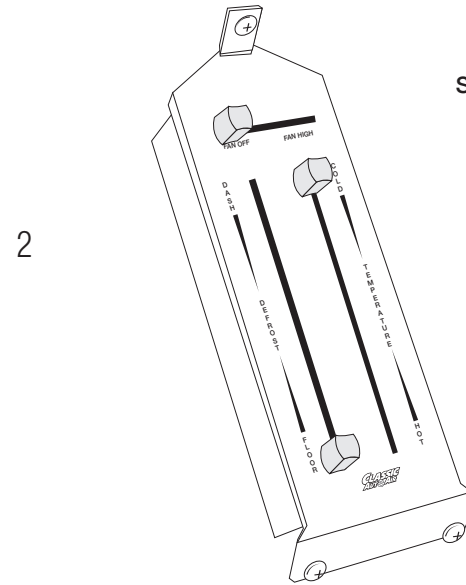

Start by positioning the D.E.R. knobs as shown:
Fan: Off
Mode: Floor
Temp: Cold

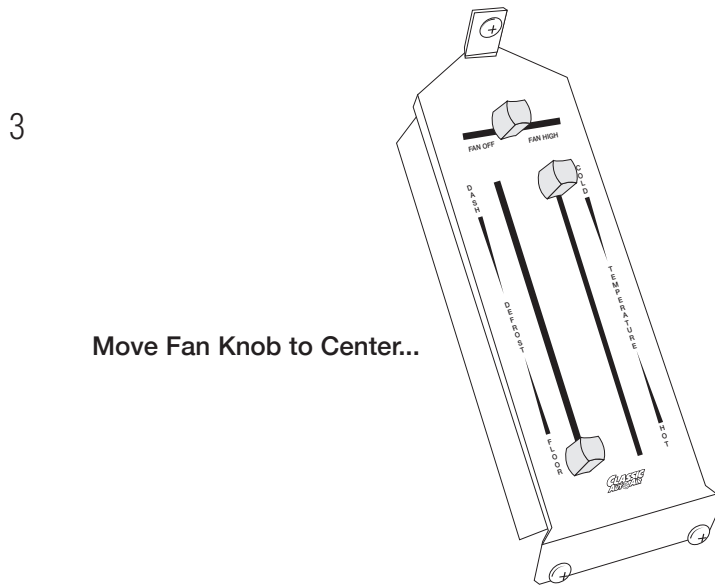

Move Fan Knob to Center...

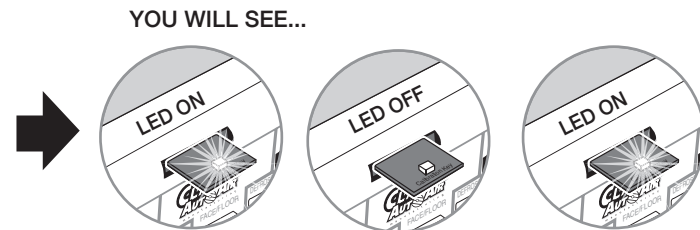

4 Move MODE knob to DASH in one motion

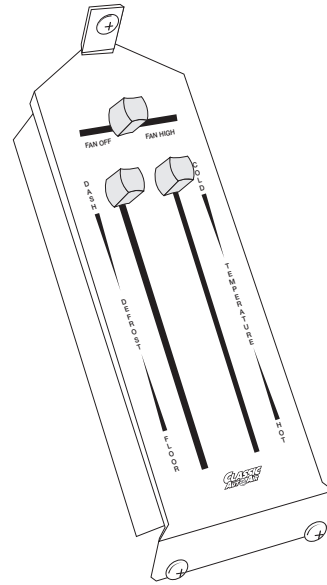

AFTER YOU MOVE THE KNOB YOU WILL SEE...

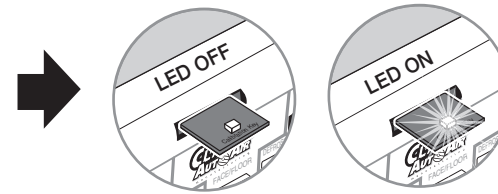

5 Move TEMP knob to HOT in one motion

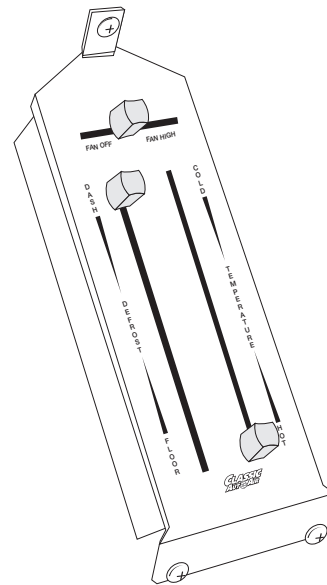

AFTER YOU MOVE THE KNOB YOU WILL SEE...

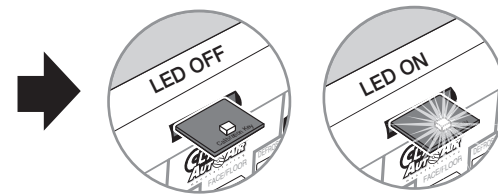

6

You will be able to hear the internal door(s) move back and forth and feel air coming out of the outlets

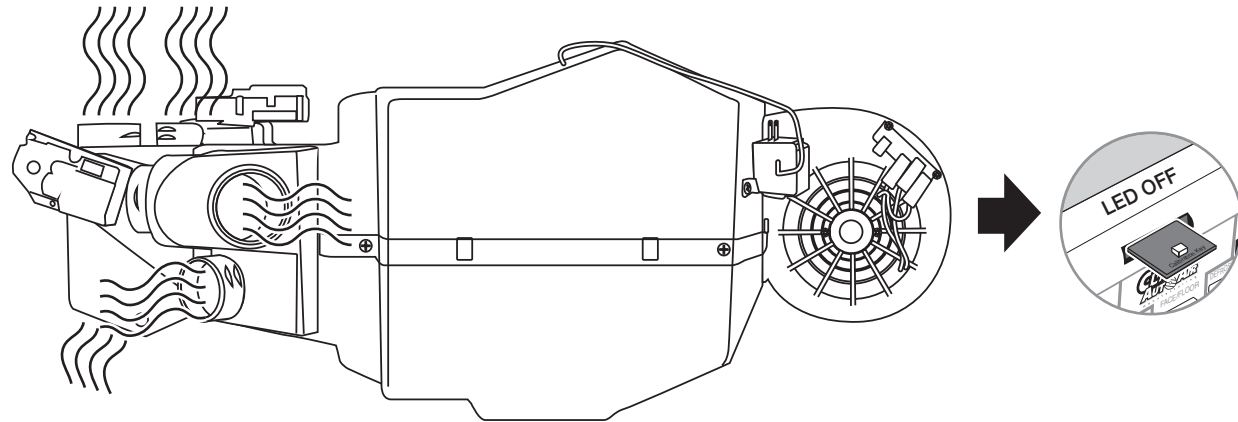

7

Move FAN knob to OFF

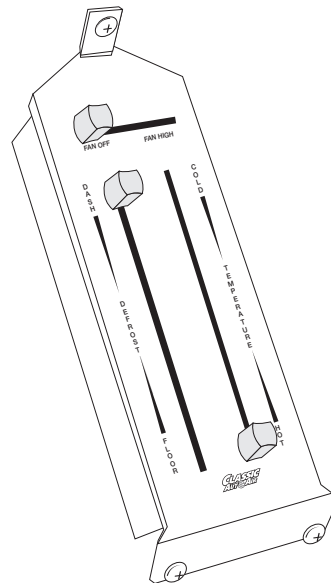

8

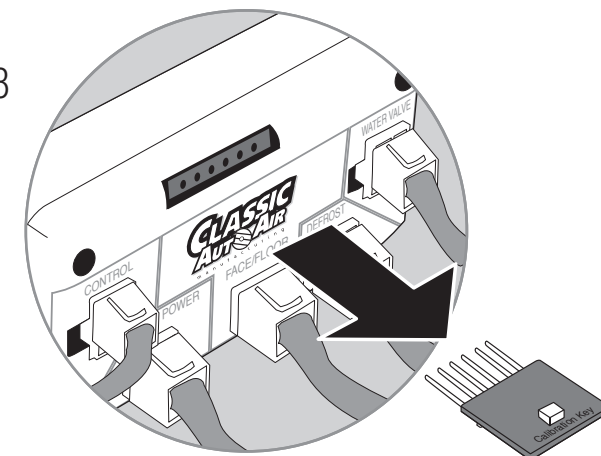

REMOVE CALIBRATION KEY FROM ECU AND STORE IN A SAFE PLACE

