



Installation Manual

1969 Chevelle/Malibu

DOCUMENT #1-2092 BENCH CALIBRATION INSTRUCTIONS



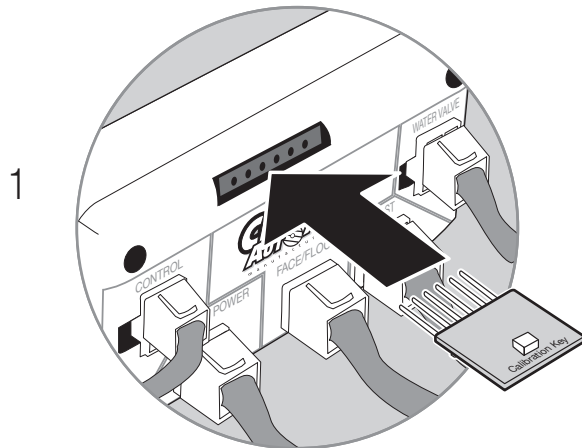

Insert Calibration Key as shown (LED up) into 6-pin connection in ECU

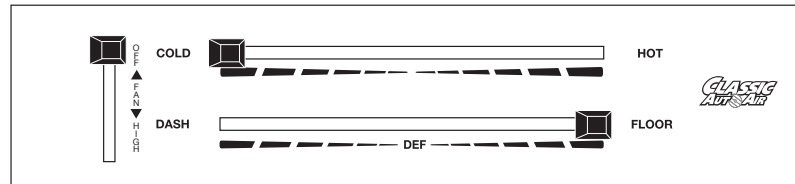

Start by positioning the control knobs as shown:

- Fan: Off
- Mode: Floor
- Temp: Cold

3

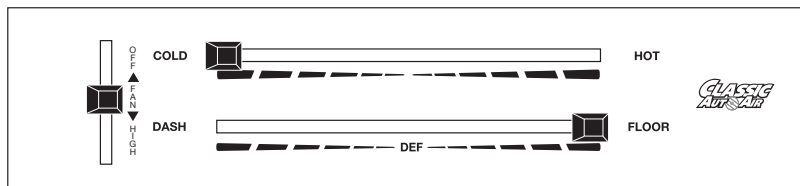

Move Fan Knob to Center...

YOU WILL SEE...

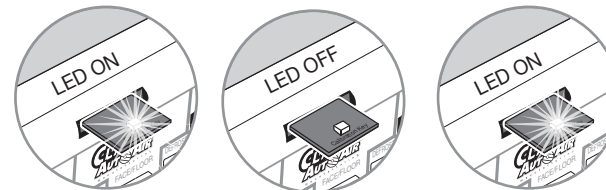

4

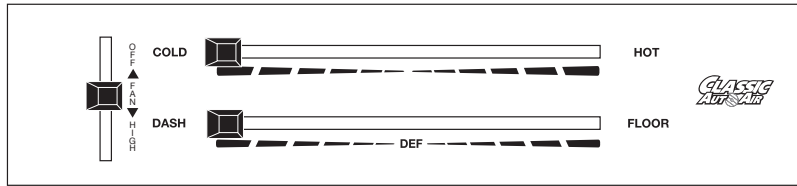

Move MODE knob to DASH
in one motion

AFTER YOU MOVE THE KNOB YOU WILL SEE...

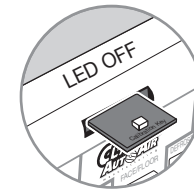

5

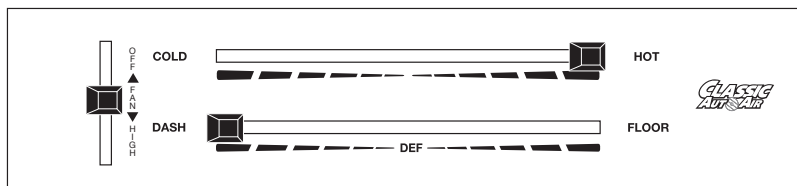

Move TEMP knob to HOT
in one motion

AFTER YOU MOVE THE KNOB YOU WILL SEE...

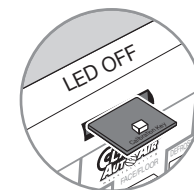

6

You will be able to hear the internal door(s) move back and forth and feel air coming out of the outlets

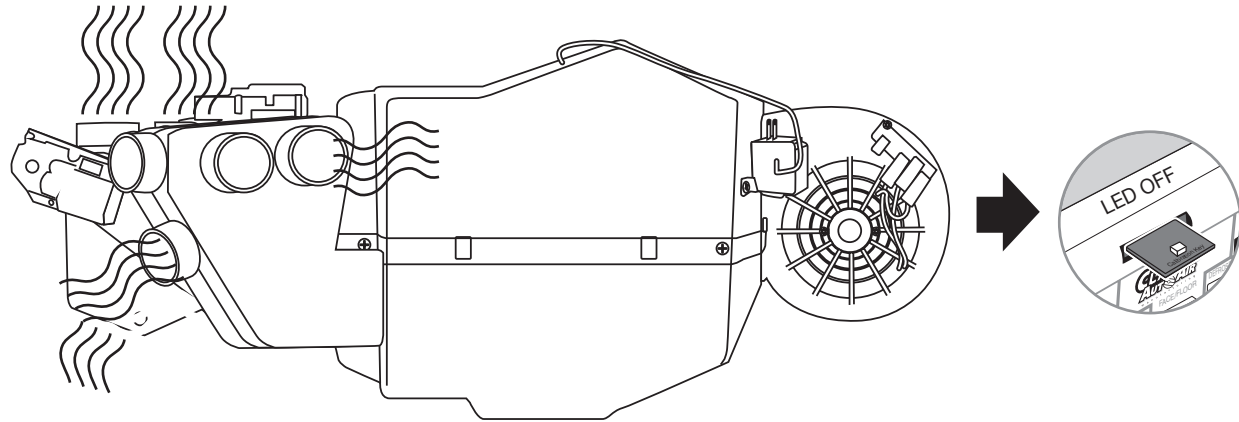

7

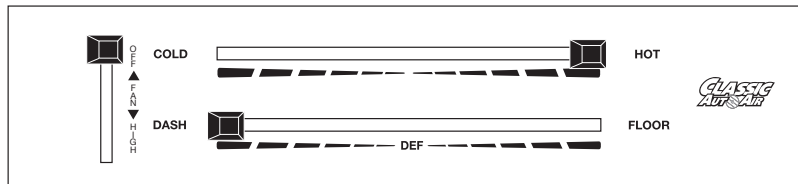

Move FAN knob to OFF

8

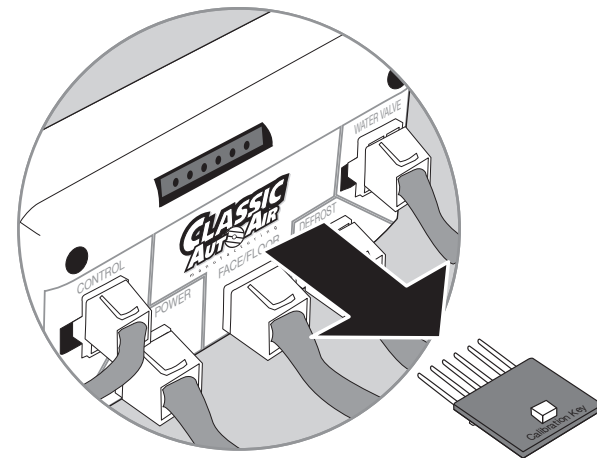

REMOVE CALIBRATION KEY FROM ECU AND STORE IN A SAFE PLACE

