



Installation Manual

1968-1969 Chevelle/Malibu Factory Air

DOCUMENT #1-2092FA BENCH CALIBRATION INSTRUCTIONS

©2018 Classic Auto Air / 12.18



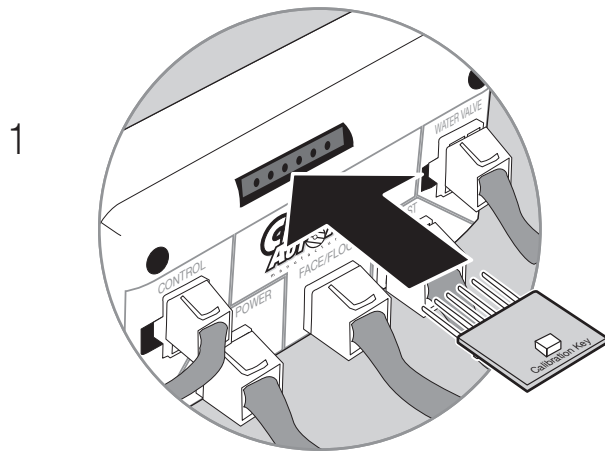

Insert Calibration Key as shown (LED up) into 6-pin connection in ECU

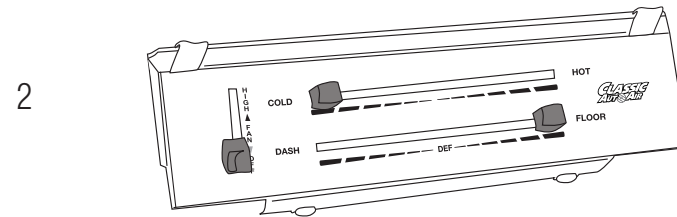

Start by positioning the control knobs as shown:
Fan: Off
Mode: Floor
Temp: Cold

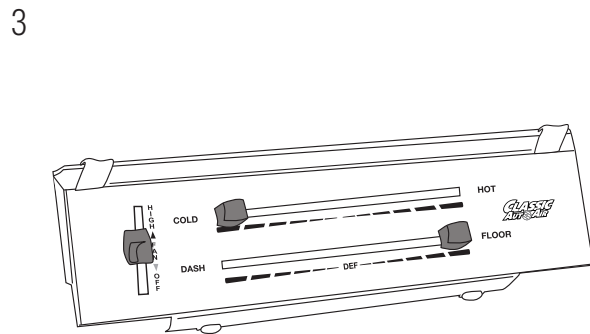

Move Fan Knob to Center...

YOU WILL SEE...

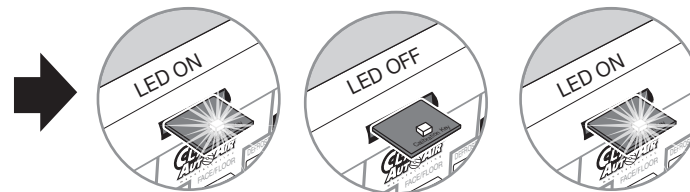

4

Move MODE knob to DASH
in one motion

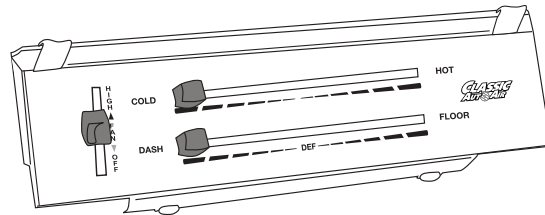

AFTER YOU MOVE THE KNOB YOU WILL SEE...

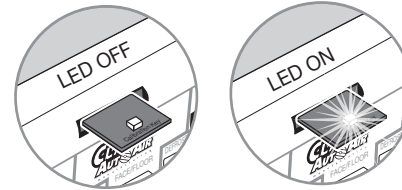

5

Move TEMP knob to HOT
in one motion

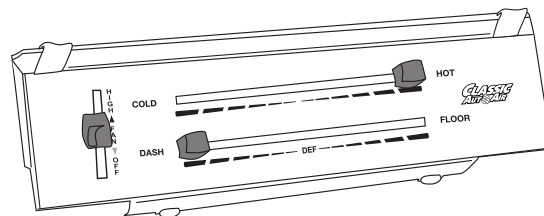

AFTER YOU MOVE THE KNOB YOU WILL SEE...

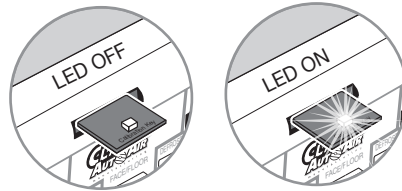

6

You will be able to hear the internal door(s) move back and forth and feel air coming out of the outlets

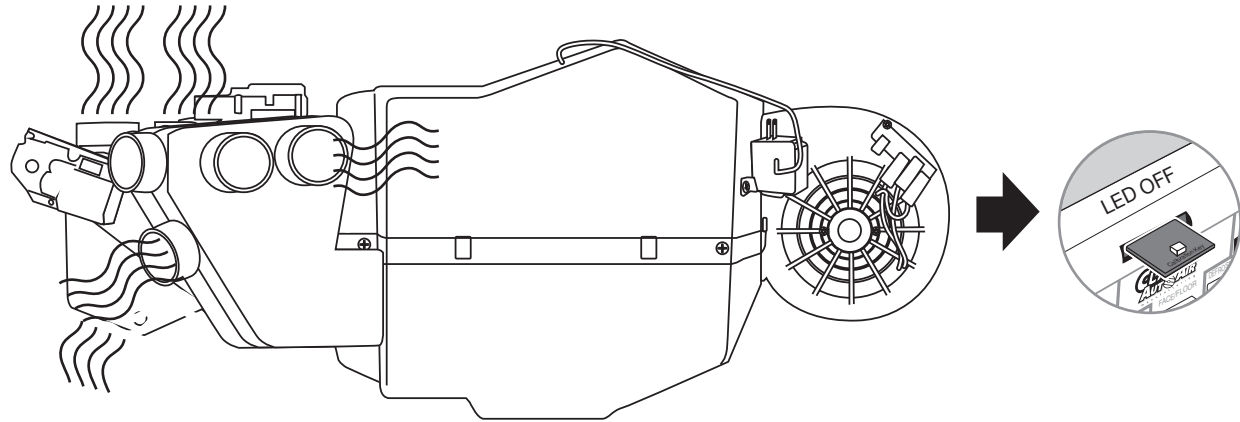

7

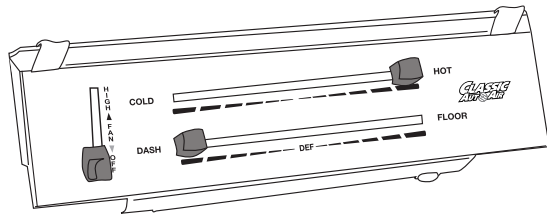

Move FAN knob to OFF

8

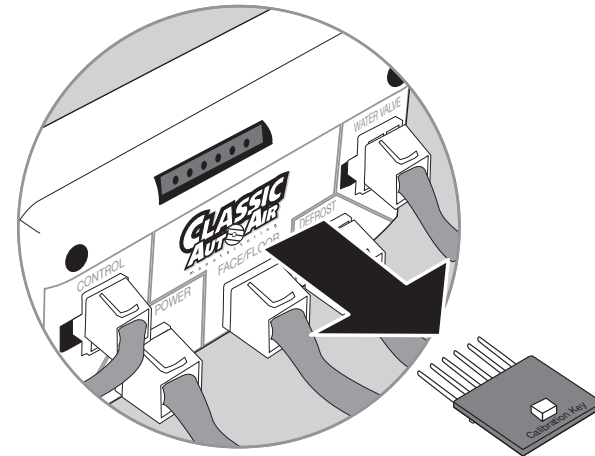

REMOVE CALIBRATION KEY FROM ECU AND STORE IN A SAFE PLACE

