



ALTERNATOR MOUNT 228L

Small Block Chevy - Short Water Pump
Driver's Side

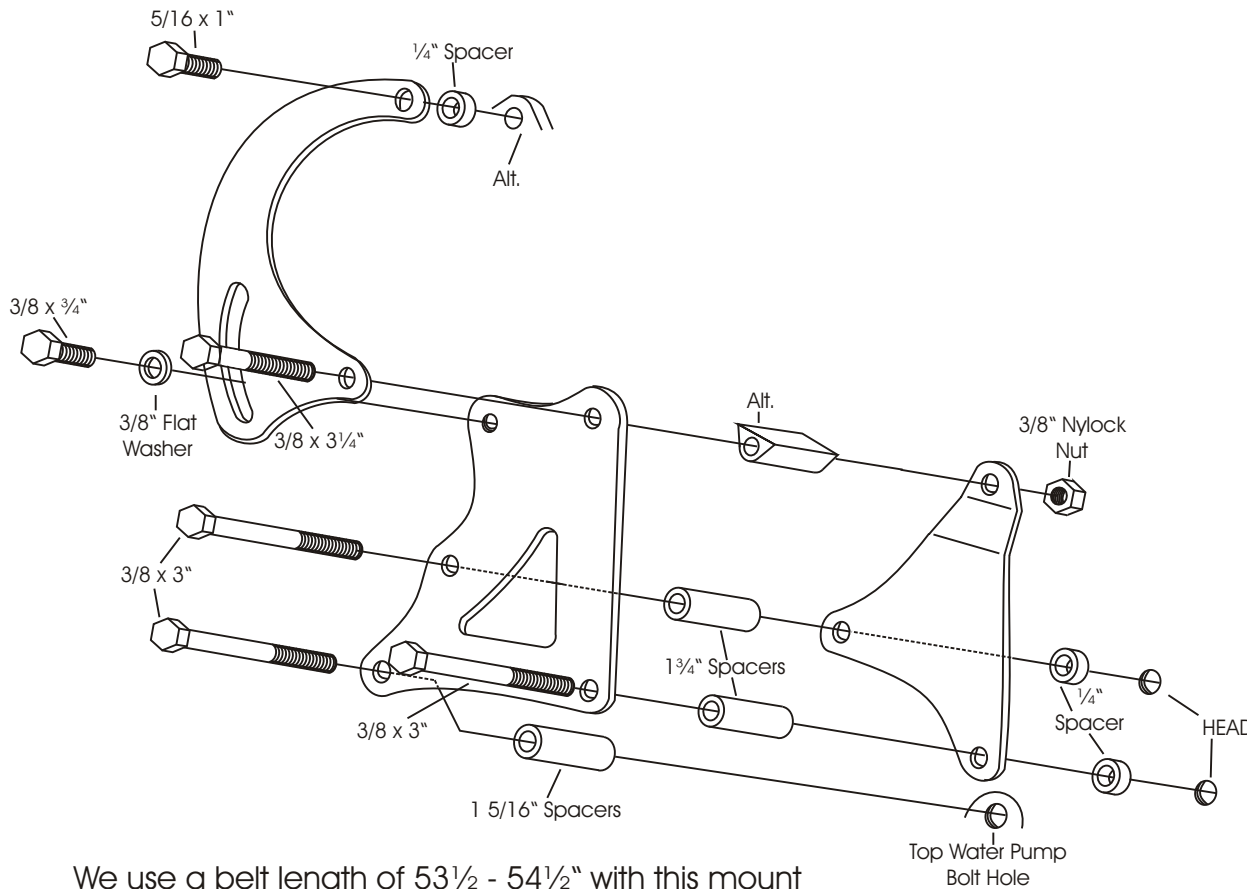
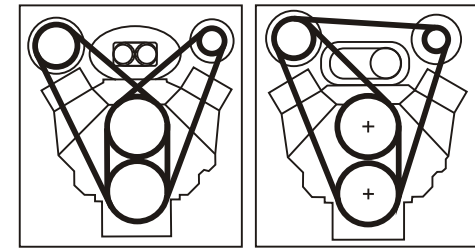

Diagram 1

Diagram 2



We use a belt length of 53½ - 54½" with this mount on installations in our shop. However; this can vary with the diameter of your pulleys.

When using both A.C. and Alt. Brackets, belts can be run either of two ways - as shown. They will require the use of 2 groove crank and water pump pulleys. Routing the belts as shown in Diagram 2 - will allow clearance for small blowers and extra room for T.P.I. air cleaners. The long belt will be approximately 70-71." As with any mount system, assemble all of the brackets to engine BEFORE TIGHTENING THE BOLTS.

As with any part of this nature, make sure it fits your application before painting or plating. Parts that have been painted, plated, or modified may not be returned.

ALTERNATOR
MOUNT
228L

Small Block Chevy - Short Water Pump
Driver's Side

ALAN GROVE COMPONENTS, INC.
27070 METCALF ROAD
LOUISBURG, KS 66053