

# POWER STEERING PUMP MOUNT 400L

Small Block Chevy - Driver's Side  
Short Water Pump



NOTE: If your pump has a stud at the lower rear pivot point, it may be used instead of the 1" bolt and .150 spacer.

We use a belt length of 36 to 36½" with this mount on installations in our shop. However; this can vary with the diameter of your pulleys.

ENGINE

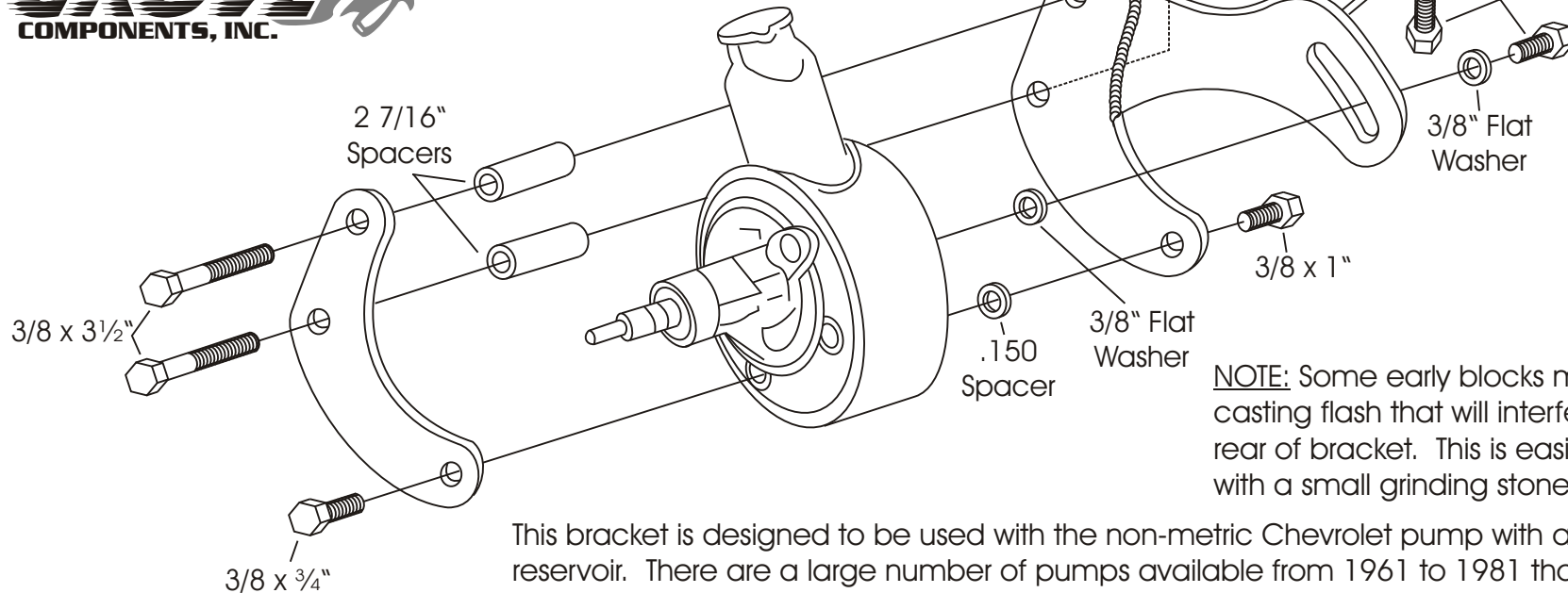

NOTE: Some early blocks may have casting flash that will interfere with the rear of bracket. This is easily removed with a small grinding stone or hand file.

This bracket is designed to be used with the non-metric Chevrolet pump with attached reservoir. There are a large number of pumps available from 1961 to 1981 that will work well with our power steering bracket. For more detailed information see the enclosed power steering pump sheet. Most short water pump applications use a crankshaft p.s. pulley that bolts over the existing pulley. This will align with the p.s. pump pulley. This pulley is available from G.M. as part number- 3751232 or from us.

**As with any part of this nature, make sure it fits your application before painting or plating. Parts that have been painted, plated, or modified may not be returned.**

POWER STEERING  
PUMP MOUNT  
400L

Small Block Chevy - Driver's Side  
Short Water Pump

**ALAN GROVE COMPONENTS, INC.**  
**27070 METCALF ROAD**  
**LOUISBURG, KS 66053**