

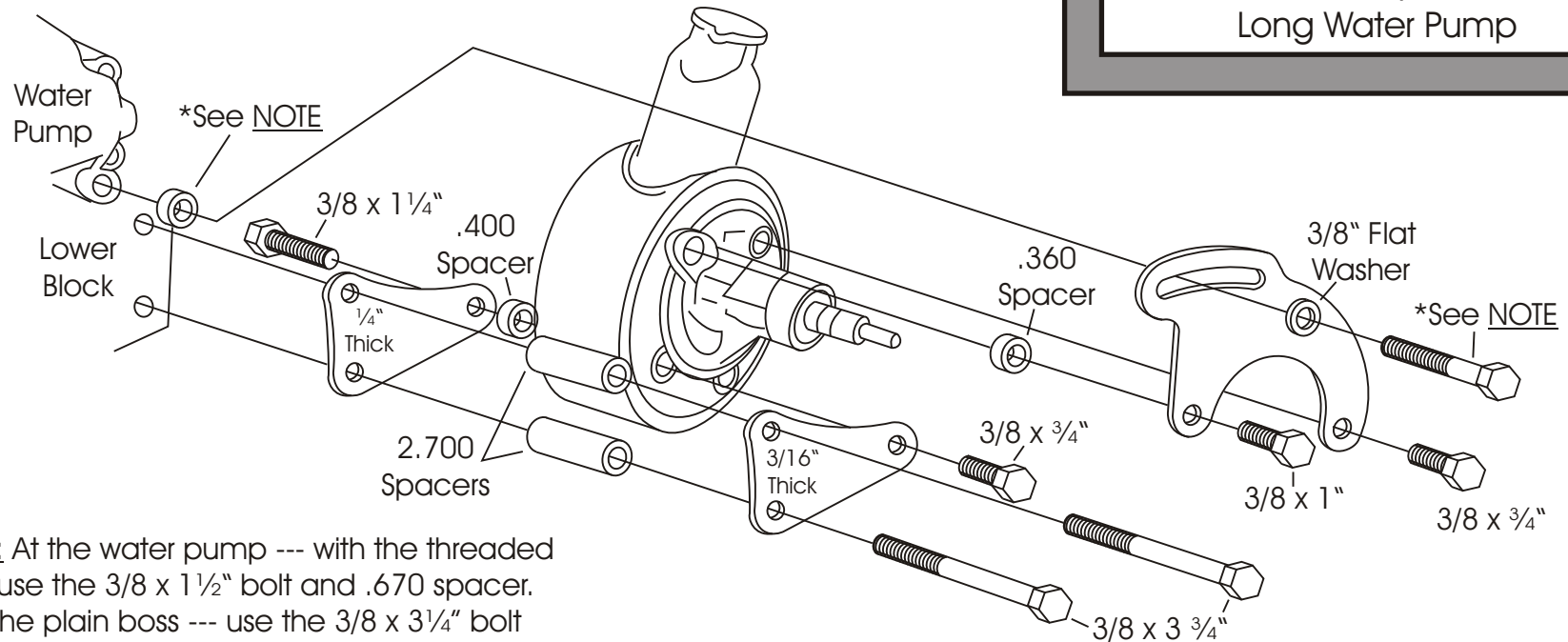

This bracket is designed to be used with the non-metric Chevrolet pump with attached reservoir. There are a large number of pumps available from 1961 to 1981 that will work well with our power steering bracket. For more detailed information see the enclosed power steering pump sheet.

# POWER STEERING PUMP MOUNT 402L

Small Block Chevy - Driver's Side Long Water Pump



NOTE: At the water pump --- with the threaded boss use the 3/8 x 1 1/2" bolt and .670 spacer. With the plain boss --- use the 3/8 x 3/4" bolt and nut, and .450 spacer.

If your pump has a stud at the lower rear pivot point, remove it and use the 1 1/4" bolt and .400 spacer.

We use a belt length of 36 1/2" - 37 1/2" with this mount on installations in our shop. However; this can vary with the diameter of your pulleys.

If the motor is to be equipped with A.C., The P.S. Pump should use a double groove pulley and the crankshaft a triple groove pulley. This will allow the use of a belt on the inner grooves of both the crankshaft and the power steering pump.

**As with any part of this nature, make sure it fits your application before painting or plating. Parts that have been painted, plated, or modified may not be returned.**

POWER STEERING  
PUMP MOUNT  
402L

Small Block Chevy - Driver's Side  
Long Water Pump

**ALAN GROVE COMPONENTS, INC.**  
**27070 METCALF ROAD**  
**LOUISBURG, KS 66053**