

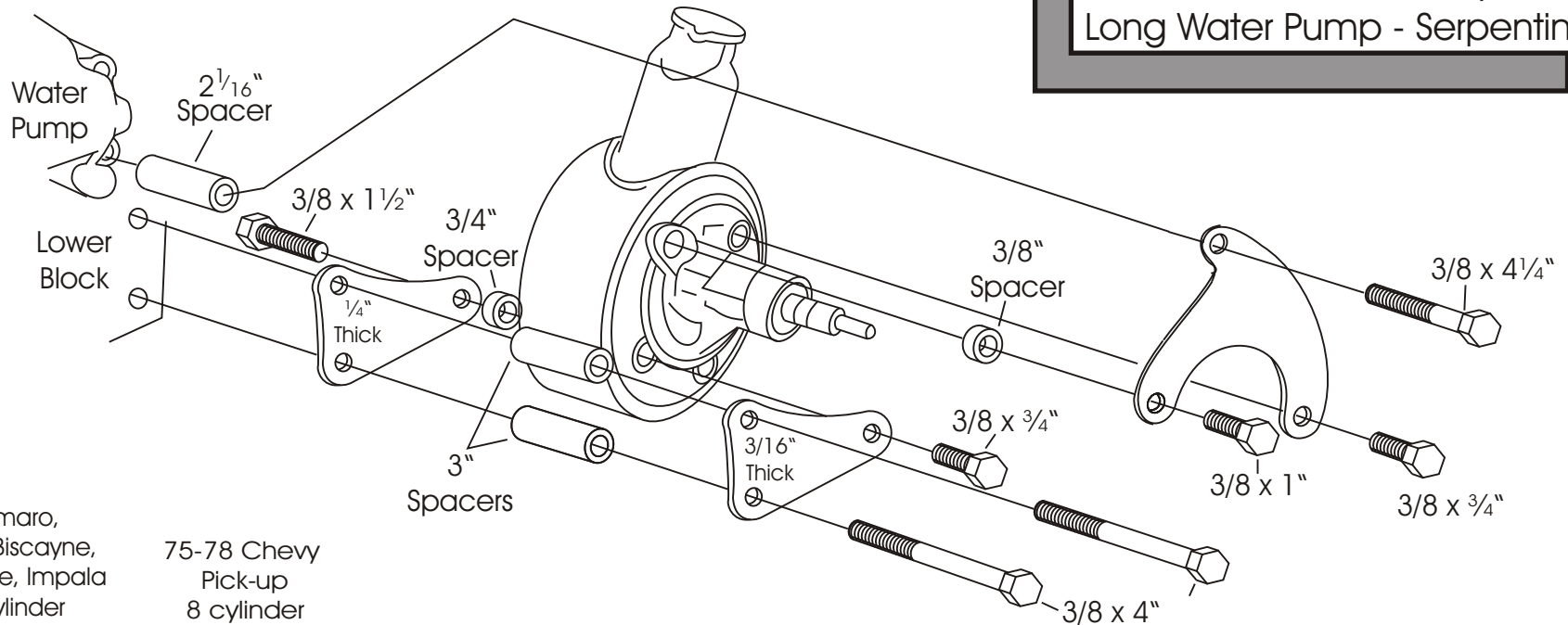

This bracket is designed to be used with the non-metric Chevrolet pump with attached reservoir, using the press on pulley GM part number 12573728. There are a number of pumps available that will work with our power steering bracket. Below are a few that we have found work well in most applications.

**POWER STEERING
PUMP MOUNT
408L**
Small Block Chevy
Long Water Pump - Serpentine



75-78 Camaro,
BelAir, Biscayne,
Caprice, Impala
8 cylinder

75-78 Chevy
Pick-up
8 cylinder

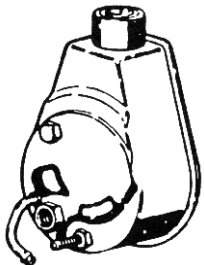

press-fit pulley
inverted flare fitting

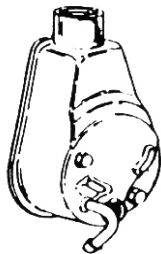

press-fit pulley
inverted flare fitting

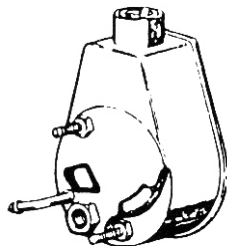

press-fit pulley
inverted flare fitting

75-79 Camaro
6 cylinder
77-79 BelAir,
Biscayne, Caprice,
Impala
6 cylinder

If your pump has a stud at the lower rear pivot point, remove it and use the 1 1/2 " bolt and 3/4" spacer.

Saginaw pump pressure may be decreased with the use of a -Flow Valve Shim Kit- part number 1001 from Mullins Steering Gears phone number (860)-482-8283.

As with any part of this nature, make sure it fits your application before painting or plating. Parts that have been painted, plated, or modified may not be returned.

POWER STEERING
PUMP MOUNT

408L

Small Block Chevy
Long Water Pump - Serpentine

ALAN GROVE COMPONENTS, INC.
27070 METCALF ROAD
LOUISBURG, KS 66053