

Part# 6-404

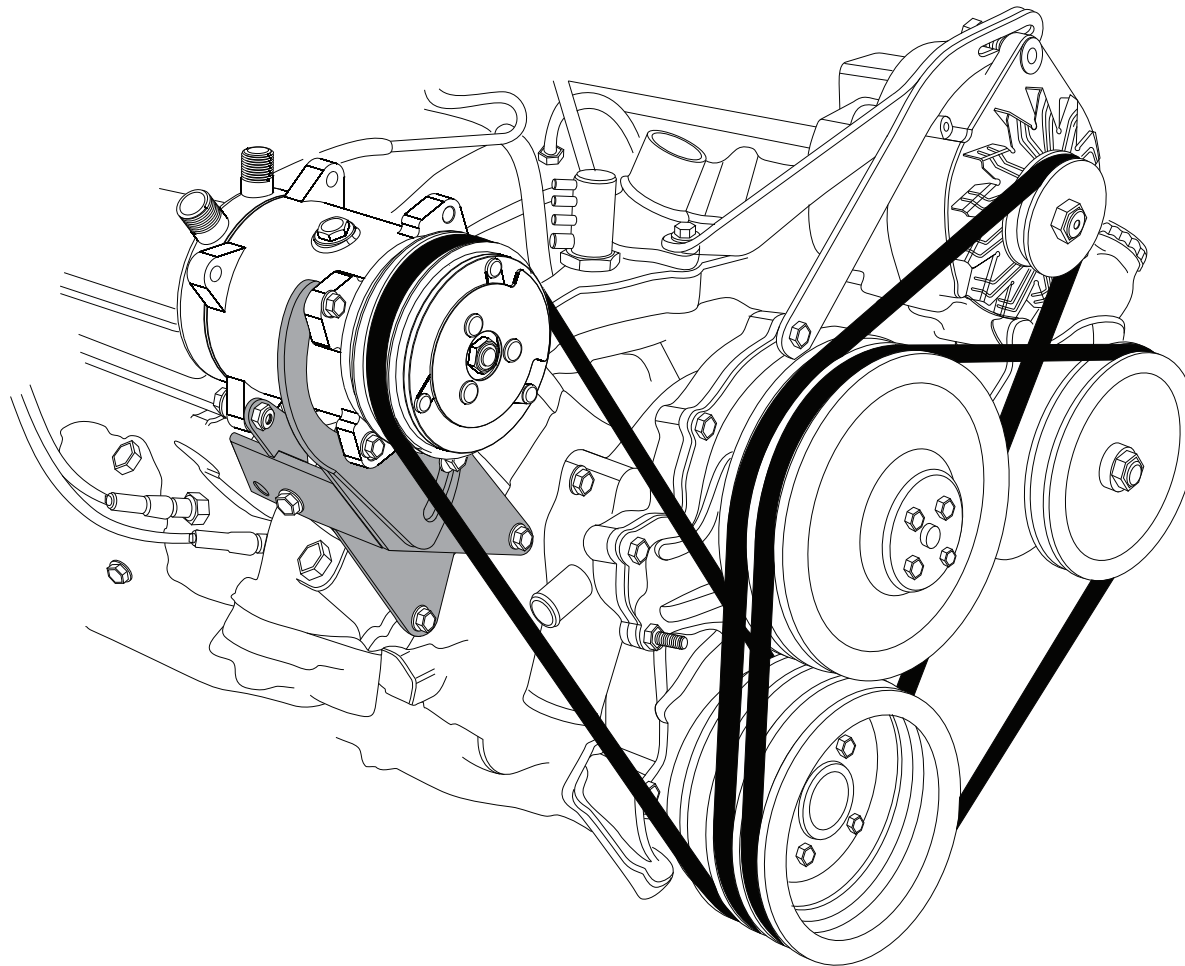

**326 - 455 Pontiac
Passenger side compressor bracket**

THESE ARE THE PARTS YOU WILL FIND IN YOUR KIT

You will use all of these parts and hardware during the next series of installation steps.

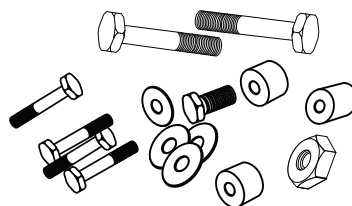
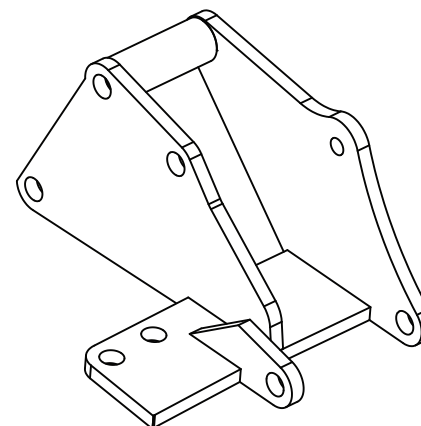
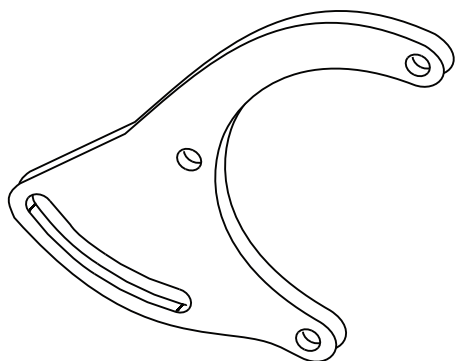

Compressor bracket can be installed to front side of cylinder head depending on configuration. Determine which configuration will be used before moving forward.

OPTION 1

Install compressor bracket assembly to front and side of Cylinder head using (3) 3/8-16 x 3/4 Hex bolts and (1) 3/8-16 x 3" Hex bolt see figure 1.

OPTION 2

Install compressor bracket assembly to front and side of cylinder head using (2) 3/8-16 x 3/4" Hex bolts and (1) 3/8-16 x 3" Hex bolt see figure 1.

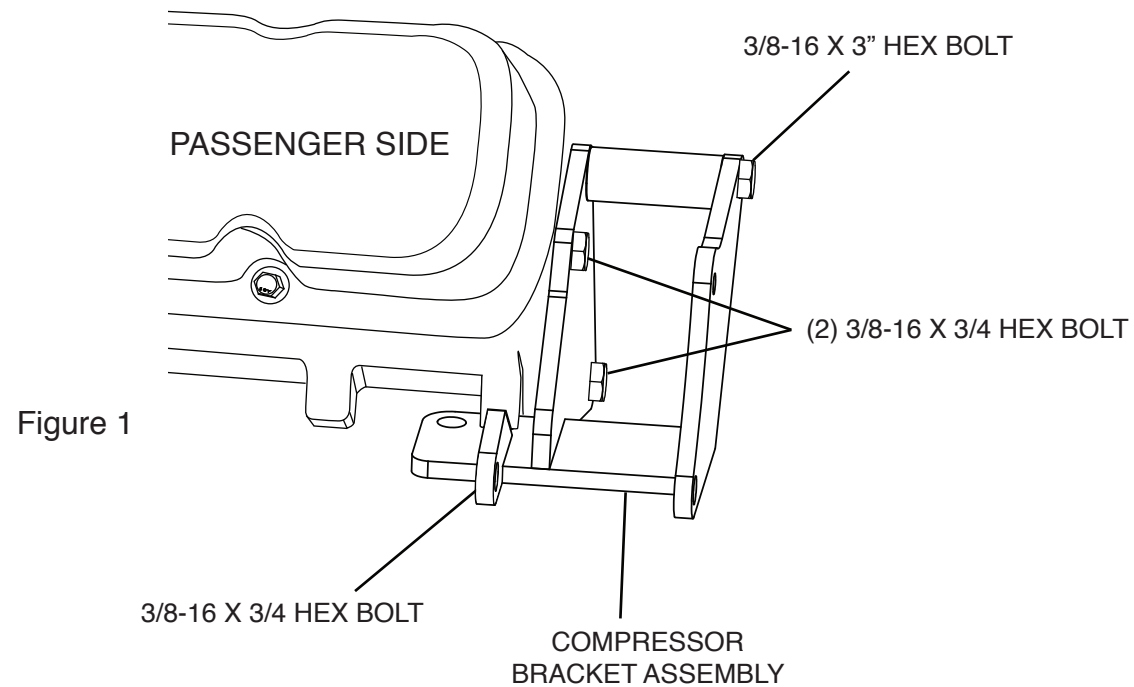

COMPRESSOR MOUNTING BRACKET INSTALLATION

INSTALL THE COMPRESSOR MOUNTING BRACKET AS SHOWN IN FIGURE 2.
SECURE USING A 3/8-16 X 1" BOLT WITH FLAT WASHER

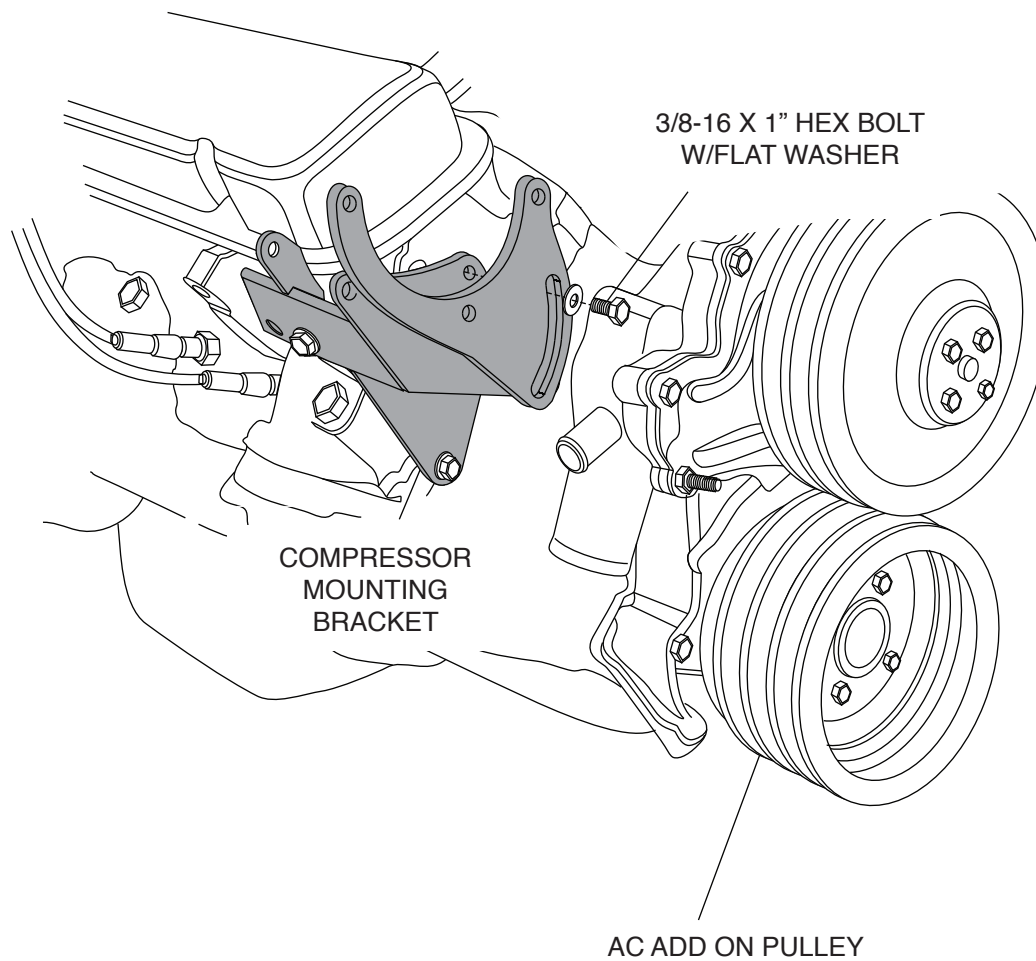

Figure 2

Install the compressor as shown in figure 3. Secure using a (3) 3/8-16 x 1 1/2" Hex bolt with lock nut and (1) 3/8-16 x 2" Hex bolt with lock nut.

NOTE:

Compressor mounts on the front side of the bracket, install the bolts through compressor then through the bracket.

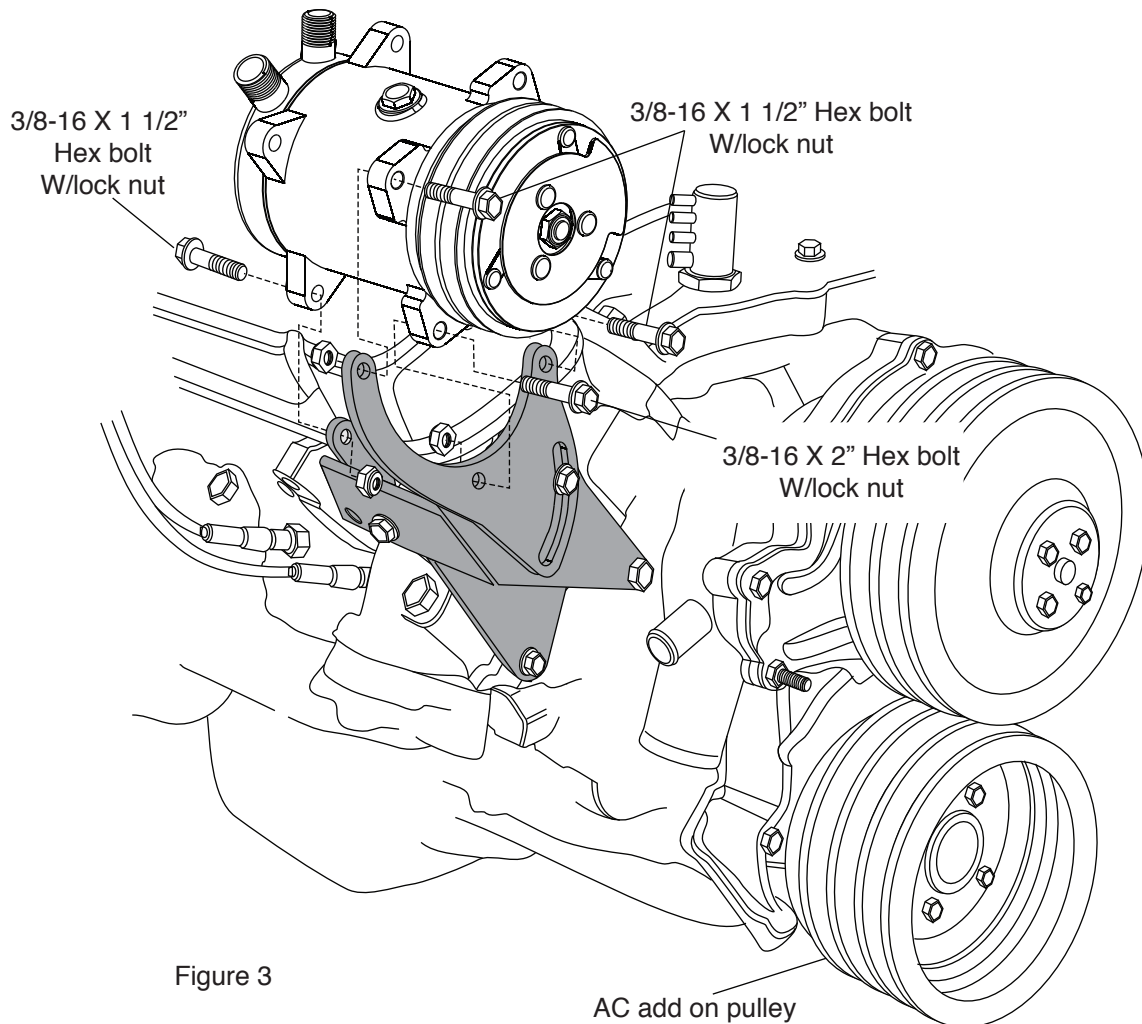
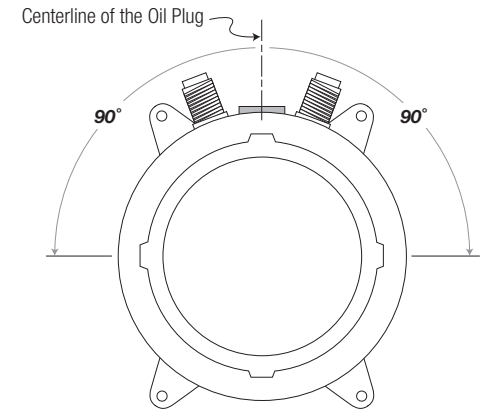
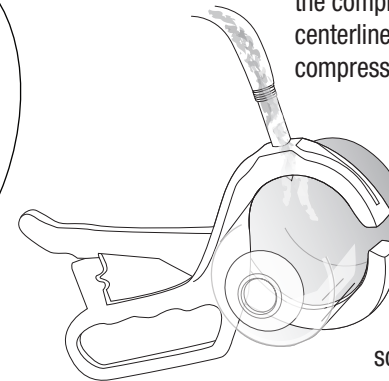

Figure 3



CAUTION! When mounting your compressor and/or adjusting the belt, use caution not to tilt the compressor up to or more than 90° off the centerline of the oil fill plug. This can cause compressor failure.



! Do **NOT** tilt, shake or turn refrigerant can upside-down OR use a charging station to install refrigerant while the engine is running. Doing

so will direct liquid refrigerant into the compressor piston chamber, causing damage to reed valves and/or pistons and/or other components, as well as potentially seizing the compressor. Allow a minimum of 30 minutes for liquid to "boil off." You must hand turn the compressor hub (not the pulley) a minimum of 15 complete revolutions prior to starting the engine with the clutch engaged.

INSTALL BELTS AS SHOWN, TIGHTEN

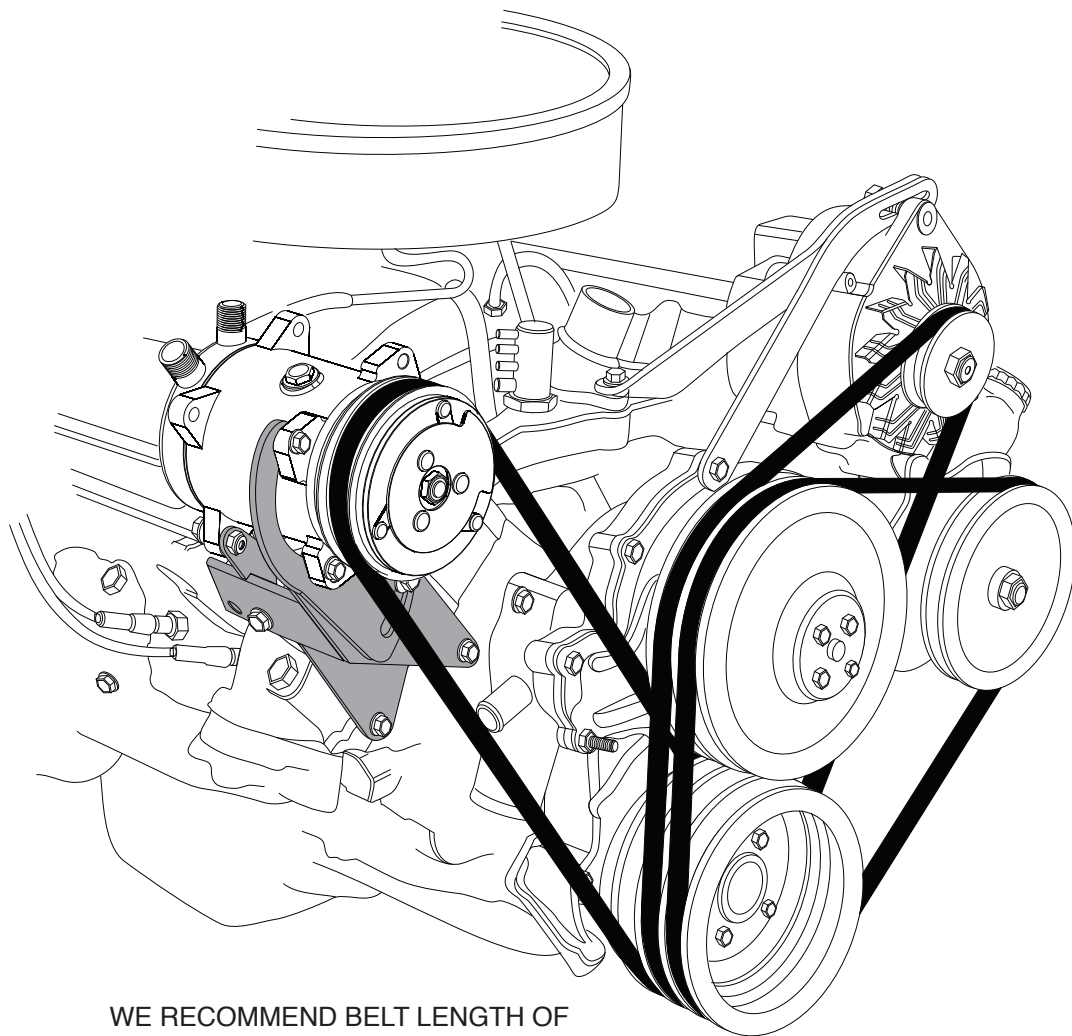

WE RECOMMEND BELT LENGTH OF 57"-58". HOWEVER THIS CAN VARY WITH THE DIAMETER OF YOUR CRANKSHAFT PULLEYS

CRANK PULLEY GROVES

- 1. CRANK, POWER STEERING & WATER PUMP
- 2. CRANK, WATER PUMP & ALTERNATOR
- 3. CRANK, COMPRESSOR

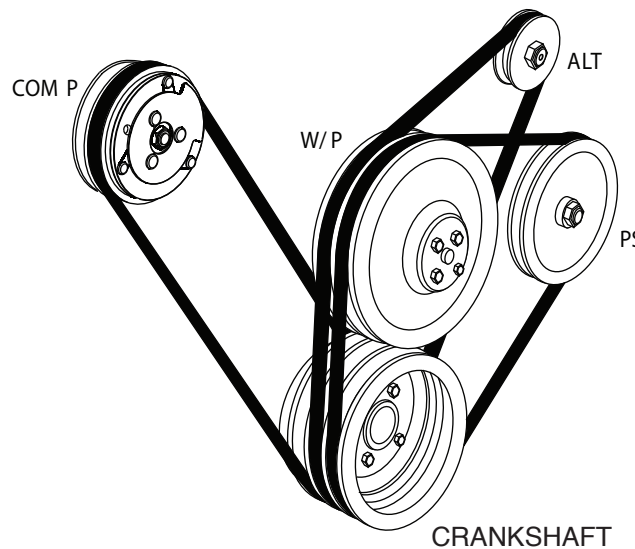

Figure 4



**64-67 PONTIAC W/OEM AC W/PS W/ 2 GROOVE WATERPUMP
2 GROOVE 6 BOLT CRANKSHAFT**

